

Indoff

INDUSTRIAL EQUIPMENT
& SUPPLIES



**THOUSANDS
OF PRODUCTS
AT YOUR
FINGERTIPS.**

WHERE SOLUTIONS TAKE SHAPE

2023

STORAGE & SHELVING	4
MATERIAL HANDLING	40
CARTS & TRUCKS	53
HVAC & FANS	69
JANITORIAL & FACILITY MAINTENANCE	79
FURNITURE & DÉCOR	103
SAFETY & SECURITY	120
MEDICAL & LABORATORY	141
PLUMBING & PUMPS	148
PACKAGING & SHIPPING	154
OFFICE & SCHOOL SUPPLIES	160
FOODSERVICE & RETAIL	164
TOOLS & INSTRUMENTS	168
MOTORS & POWER TRANSMISSION	178
LIGHTING & ELECTRICAL	179
MACHINING	182
FASTENERS & HARDWARE	186
BUILDING SUPPLIES	188
VEHICLE MAINTENANCE	189
WORKBENCHES & SHOP DESKS	191



This catalog is just a sampling of our lineup of proven industrial equipment and supplies.

Copyright © 2023 Global Industrial All Rights Reserved. Prices Subject To Change.

CAN IT BE MADE BETTER?

We looked at popular products and started with a simple question: Can it be made better?

This led us to completely rethink how products are designed, built, and guaranteed. Each step along the way, we had you, our customer, front-and-center in our minds.



QUALITY

Made with quality materials by industry experts, offering strength and long-lasting durability to help drive your business forward.



IN STOCK

Exclusive Brands™ products are available to ship within 24 hours, helping your day-to-day operations stay on track.



INDUSTRY STANDARDS

Designed to meet or exceed industry standards, carrying our full endorsement.



SOMETHING EXTRA

Made with your business in mind and constructed with precision, offering added features and robust support components.



WARRANTY

We back each of our products with a competitive warranty for your peace of mind. Warranty length varies by product and some exclusion and restrictions apply.

MADE TO EXCEED.™

EXCLUSIVE BRANDS

STORAGE & SHELVING

4-38

EXCLUSIVE BRANDS

HEAVY-DUTY 18- & 20-GAUGE INDUSTRIAL STEEL SHELVING

- X-shaped anti-sway braces increase rigidity and provide more support on uneven floors than regular lateral braces
- Braces cover perimeter of rack instead of aligning at just one point

Customized to your special needs at no extra cost, heavy-duty steel shelving units have been engineered to adapt to your storage requirements. Ideal for stockroom, factory, or office where extra storage space is needed. Ribbed roll-formed steel shelves with integral box beam-reinforced front and rear edges for greater load capacity.

Shelves are easily adjustable on 1" centers. Rib-reinforced 14-gauge 1" x 2" steel posts. Phosphatized to prevent corrosion with maximum paint adhesion. Finished in long-lasting, baked-on gray enamel.



562167A

73" | 20 gauge | 36" x 18" | 6 shelves

Consists of 4 posts, specified number of shelves, 4 clips per shelf, 1 pair back braces, 2 pair of side braces, and necessary nuts and bolts.

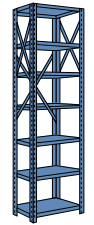
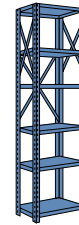
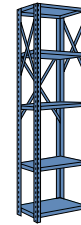
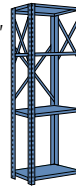

SHELF LOAD CAPACITIES		
Shelf Size"	20 Ga. Cap. Lbs.	18 Ga. Cap. Lbs.
36 x 12	775	975
36 x 18	750	1050
36 x 24	775	1100
36 x 30	785	1110
48 x 12	525	600
48 x 18	540	650
48 x 24	550	700
48 x 30	560	710

73" HIGH (6' 1")

W" X D"	4 SHELVES		5 SHELVES		6 SHELVES		7 SHELVES	
	20 GAUGE	18 GAUGE	20 GAUGE	18 GAUGE	20 GAUGE	18 GAUGE	20 GAUGE	18 GAUGE
36 x 12	234000A	562150A	234064A	562158A	234128A	562166A	234129A	562174A
36 x 18	234004A	562151A	234068A	562159A	234132A	562167A	234131A	562175A
36 x 24	234008A	562152A	234072A	562160A	234136A	562168A	234133A	562176A
36 x 30	234012A	562153A	234076A	562161A	234140A	562169A	234135A	562177A
48 x 12	234032A	562154A	234096A	562162A	234160A	562170A	234137A	562178A
48 x 18	234036A	562155A	234100A	562163A	234164A	562171A	234139A	562179A
48 x 24	234040A	562156A	234104A	562164A	234168A	562172A	234141A	562180A
48 x 30	234044A	562157A	234108A	562165A	234172A	562173A	234143A	562181A

4 SHELVES 5 SHELVES 6 SHELVES 7 SHELVES

85" HIGH (7' 1")

W" X D"	4 SHELVES		5 SHELVES		6 SHELVES		7 SHELVES	
	20 GAUGE	18 GAUGE	20 GAUGE	18 GAUGE	20 GAUGE	18 GAUGE	20 GAUGE	18 GAUGE
36 x 12	234192A	562182A	234191A	562190A	234256A	562198A	234310A	562206A
36 x 18	234196A	562183A	234193A	562191A	234260A	562199A	234314A	562207A
36 x 24	234200A	562184A	234195A	562192A	234264A	562200A	234318A	562208A
36 x 30	234204A	562185A	234197A	562193A	234268A	562201A	234322A	562209A
48 x 12	234224A	562186A	234199A	562194A	234278A	562202A	234342A	562210A
48 x 18	234228A	562187A	234201A	562195A	234282A	562203A	234346A	562211A
48 x 24	234232A	562188A	234203A	562196A	234286A	562204A	234350A	562212A
48 x 30	234236A	562189A	234205A	562197A	234290A	562205A	234354A	562213A

97" HIGH (8' 1")

W" X D"	4 SHELVES		5 SHELVES		6 SHELVES		7 SHELVES	
	20 GAUGE	18 GAUGE	20 GAUGE	18 GAUGE	20 GAUGE	18 GAUGE	20 GAUGE	18 GAUGE
36 x 12	234363A	562214A	234374A	562222A	234438A	562230A	234502A	562238A
36 x 18	234367A	562215A	234378A	562223A	234442A	562231A	234506A	562239A
36 x 24	234371A	562216A	234382A	562224A	234446A	562232A	234510A	562240A
36 x 30	234375A	562217A	234386A	562225A	234450A	562233A	234514A	562241A
48 x 12	234381A	562218A	234406A	562226A	234470A	562234A	234534A	562242A
48 x 18	234385A	562219A	234410A	562227A	234474A	562235A	234538A	562243A
48 x 24	234389A	562220A	234414A	562228A	234478A	562236A	234542A	562244A
48 x 30	234393A	562221A	234418A	562229A	234482A	562237A	234546A	562245A



562159A x 3
73" | 18-gauge | 48" x 24" | 5 shelves



Ultimate load-bearing capability with **Heavy-Duty Quad Clips**

Extra shelf clip (pkg. of 4) **234071A**

CUSTOM DESIGN YOUR PERFECT SHELVING

Call us and start building the right shelving for you.

ACCESSORIES

SHELVES - Steel, box-formed on front and rear for added strength and safety. Shelves are punched on 2" centers for divider adjustment. Includes shelf clips.

4 SHELVES			
20 GAUGE		18 GAUGE	
W" x D"	Model	W" x D"	Model
36 x 12	234048	36 x 12	254242
36 x 18	234050	36 x 18	254243
36 x 24	234052	36 x 24	254244
36 x 30	234054	36 x 30	254245
48 x 12	234056	48 x 12	254246
48 x 18	234058	48 x 18	254247
48 x 24	234060	48 x 24	254248
48 x 30	234062	48 x 30	254249

UPRIGHT POSTS - Heavy-duty 14-gauge 1" x 2" roll-formed post, punched on 1" centers for easy adjustment. Package of 4 includes anti-sway braces, nuts, and bolts.

H"	Model	H"	Model
39	254302	—	—
—	—	85	254305
73	254304	97	254306

UNIVERSAL BRACE KIT Model 254405 - Contains 1 pair back anti-sway and 2 pair side anti-sway braces.

HOLDEX LABEL HOLDERS - Identify inventory and designated supply areas. Reusable clear plastic strips with paper inserts allow you to relabel quickly and easily. Self-adhesive style adheres to any clean surface, while magnetic strips are for use with steel surfaces. Packaged 12 label holders per box.



W" x H"	SELF-ADHESIVE Model	MAGNETIC Model
6 x ¾	952000	952002
6 x 1	952003	952004
6 x 2	952072	952067



DOUBLE-RIVET BEAMS

When additional weight capacity is needed.



EXTRA HEAVY-DUTY BOLTLESS SHELVING

- Rugged steel shelving features super-strong roll-formed steel framing
- Positive interlocking beam-and-post connections for quick snap-in assembly
- Easily-adjustable shelf levels include double-rivet support for added rigidity
- Levels adjust at 1½" increments and permit 4-way access
- Durable gray baked enamel with ¾" particleboard decking

SHELF CAPACITIES	
W" x D"	Lbs./Shelf
48 x 18	1500
48 x 24	1500

5 SHELVES	
W" x D" x H"	MODEL
48 x 18 x 72	255684
48 x 18 x 84	601888
48 x 18 x 96	601888H
48 x 24 x 60	255441
48 x 24 x 72	255685
48 x 24 x 84	601889
48 x 24 x 96	601889H

BOLTED PALLET RACKS

- Upright frames are pre-assembled for quick and easy set-up
- Teardrop frame design allows for shelf adjustment in 2" increments
- Pre-punched foot plates allow for easier floor anchoring



8' HIGH				10' HIGH				12' HIGH			
W" x D"	Beam H"	Cap. Pair	Model	W" x D"	Beam H"	Cap. Pair	Model	W" x D"	Beam H"	Cap. Pair	Model
108 x 42	5 1/8	6420	B3121253	108 x 48	5 1/8	6420	B3121277	108 x 48	5 1/8	6420	B3121301
108 x 48	5 1/8	6420	B3121265	120 x 48	5 1/8	5630	B3121279	120 x 42	5 1/8	5630	B3121295
120 x 42	5 1/8	5630	B3121258	144 x 48	6	5970	B3121281	120 x 48	5 1/8	5630	B3121303
120 x 48	5 1/8	5630	B3121271	48 x 48	3 3/16	6590	B3121245	144 x 42	6	5970	B3121292
144 x 42	6	5970	B3121260	96 x 48	3 3/16	3230	B3121283	144 x 48	6	5970	B3121305
144 x 48	6	5970	B3121273	96 x 48	3 3/16	3230	B3121285	48 x 42	3 3/16	6590	B3121249
48 x 42	3 3/16	6590	B3121248	96 x 48	3 3/16	3230	B3121287	48 x 48	3 3/16	6590	B3121251
48 x 48	3 3/16	6590	B3121243	96 x 48	3 3/16	3230		96 x 42	3 3/16	3230	B3121294
96 x 42	3 3/16	3230	B3121256					96 x 42	3 3/16	3230	B3121297
96 x 42	3 3/16	3230	B3121261					96 x 42	3 3/16	3230	B3121299
96 x 42	3 3/16	3230	B3121263					96 x 48	3 3/16	3230	B3121307
96 x 48	3 3/16	3230	B3121268					96 x 48	3 3/16	3230	B3121309
96 x 48	3 3/16	3230	B3121270					96 x 48	3 3/16	3230	B3121311
96 x 48	3 3/16	3230	B3121275					108 x 42	5 1/8	6420	B3121289

TEARDROP PALLET RACKS

- Offer quick and easy, tool-free assembly for all your pallet storage needs
- Pre-configured industrial storage rack systems made of durable heavy-gauge steel
- Beams connect to upright frame using a positive 6-way locking action
- Capacity based on 36" beam shelf spacing



8' HIGH				10' HIGH				12' HIGH			
W" x D"	Beam H"	Cap. Pair	Model	W" x D"	Beam H"	Cap. Pair	Model	W" x D"	Beam H"	Cap. Pair	Model
48 x 36	3 3/16	6590	796560N	48 x 42	3 3/16	6590	796590N	48 x 42	3 3/16	6590	796610N
48 x 42	3 3/16	6590	796570N	48 x 48	3 3/16	6590	796600N	96 x 42	4 1/2	5030	796612N
48 x 48	3 3/16	6590	796580N	96 x 42	4 1/2	5030	796592N	96 x 42	5 1/8	7160	796614N
96 x 36	4 1/2	5030	796562N	96 x 42	5 1/8	7160	796594N	108 x 42	5 1/8	6420	796616N
96 x 36	5 1/8	7160	796564N	96 x 48	4 1/2	5030	796602N	120 x 42	5 1/8	5630	796618N
96 x 42	4 1/2	5030	796572N	96 x 48	5 1/8	7160	796604N	144 x 42	6	5970	320864
96 x 42	5 1/8	7160	796574N	108 x 42	5 1/8	6420	796596N	144 x 48	6	5970	320865
96 x 48	4 1/2	5030	796582N	108 x 48	5 1/8	6420	796606N				
96 x 48	5 1/8	7160	796584N	120 x 42	5 1/8	5630	796598N				
108 x 36	5 1/8	6420	796566N	120 x 48	5 1/8	5630	796608N				
108 x 42	5 1/8	6420	796576N	144 x 42	6	5970	320868				
108 x 48	5 1/8	6420	796586N	144 x 48	6	5970	320869				
120 x 36	5 1/8	5630	796568N								
120 x 42	5 1/8	5630	796578N								
120 x 48	5 1/8	5630	796588N								
144 x 36	6	5970	320858								
144 x 42	6	5970	320859								

Global Industrial - Pallet Rack Disclaimer: If seismic conditions apply, verification of capacities must be confirmed with a seismic engineer. Global Industrial is not responsible for engineering, installation and/or application of this material. Global Industrial is not responsible for permits. It is the full responsibility of the customer to check the contents and quantities. The payload capacity rating(s) provided are for reference only. These ratings apply to static (non-seismic) conditions only.

STORAGE & SHELVING

EXCLUSIVE BRANDS



298531

HEAVY-DUTY GALVANIZED STEEL PALLETS

- Heavy-duty welded steel with galvanized finish for rust-resistance
- Offers 8,000 lb. static, 4,000 lb. fork, and 2,200 lb. rack capacity
- 3.9"H fork openings allow 4-way fork access for fork trucks and pallet jacks

Model	L" x W" x H"	Entry	Bottom Stringers	Cap. Lbs.		
				Fork	Floor	Rack
298531	36 x 36 x 4¾	Four-Way	3	4000	8000	2200
298532	48 x 40 x 4¾	Two-Way	5	4000	8000	2200
298533	48 x 42 x 4¾	Two-Way	5	4000	8000	2200
298534	48 x 48 x 4¾	Two-Way	5	4000	8000	2200



270274

WOODEN PALLETS

- Wood pallets are an economical alternative to plastic pallets
- Constructed with 7 top boards and 5 bottom boards for durability
- Stackable to save space. Perfect for storing and shipping
- Fork openings are on the width side. Meets GMA standard

Model	L" x W" x H"	Entry	Weight Capacity
270274	48" x 40" x 4½"	4 - Way	2800
270275	48" x 48" x 4½"	2 - Way	3500



268813

EURO PLASTIC PALLETS

- Designed to meet European standards for import/export shipping
- Pallets nest when not in use for efficient storage
- Allows 4-way forklift entry

Model	Description	L" x W" x H"	Fork Cap. Lbs.	Floor Cap. Lbs.
268812	Nestable	48 x 32 x 5½	2200	8800
268813	Stackable	48 x 32 x 6	2200	8800

EXCLUSIVE BRANDS



236642

NESTABLE PLASTIC PALLETS

- Durable and cost-effective polyethylene
- Weather-resistant construction won't split, rot, or mildew
- Quality plastic pallets offer better alternative to wood pallets

Model	L" x W" x H"	Fork Cap. Lbs.	Floor Cap. Lbs.
236642	48 x 40 x 5½	2750	15000
270207	48 x 40 x 5¾	1200	3000
268811	32 x 24 x 5	2200	5500

EXCLUSIVE BRANDS



412511

RACKABLE PLASTIC PALLET

- One-piece, high-pressure injection molded high-density polyethylene plastic
- Ideal for food processing, meat, poultry and pharmaceutical applications
- 100% recyclable pallets offer a unique rib-reinforced design to minimize dirt and dust collection
- 48L" x 40W" x 6H"
- Payload capacity: 4000 lb fork, 30,000 lb floor, 2300 lb rack



268819

AUTOMOTIVE PLASTIC PALLETS

- Specially-designed for automotive applications
- Allows 4-way forklift entry
- Exempt from ISPM 15 regulation for export shipping

Model	Description	L" x W" x H"	Fork	Cap. Lbs.	
				Floor	Rack
270291	Stackable	48 x 45 x 6	4000	30000	3500
268819	Nestable	48 x 45 x 5½	2200	5000	---

BEAM PAIRS

High-strength one-piece tube-seamed steel beams, with a powder coat polyester finish. Step-beam design accommodates cross bars and decking. Beams provide secure connections to upright frames using 3-button positive-locking studs plus self-engaging spring-loaded safety clip. Full C-type weld construction ensures maximum durability under all conditions.



245970

Model	Clear Span"	Cap. Lbs./Pr.	Beam Ht."
245970	48	6590	3 ⁵ / ₁₆
597001	96	3230	3 ⁵ / ₁₆
245972	96	5030	4 ¹ / ₂
245973	96	7160	5 ¹ / ₈
245975	108	6420	5 ¹ / ₈
245976	120	5630	5 ¹ / ₈
597007	144	5970	6

RIGID ROW SPACER

Used to connect and space rack back-to-back for added stability.



For uniform spacing between racks and pallets. 4"H.

Model	Depth"
796353	6
796354	8
796355	12

B2051763



STEEL WIRE DECK DIVIDERS

Dividers can be used to separate product, or to prevent it from falling off shelves. Securely attach to wire shelves with 2 clips.

Model	D" x H"
B2051763	34 x 10
B2051767	42 x 10
968641	34 x 18
968642	40 x 18
968643	46 x 18

798617



WRAP-AROUND FRAME GUARDS

Help protect pallet rack uprights from forklift damage. Convenient frame guard is made of durable 9-gauge steel.

Model	H"
798617	12
798618	18

PALLET RACK UPRIGHT FRAMES

- Welded 13-gauge steel
- Punched on 2" centers for easy beam adjustment
- Long-lasting baked-on enamel finish
- Capacity based on 36" beam shelf spacing



320812

Model	H" x D"	Capacity Lbs./Pr.	Column Size"
320812	96 X 36	27600	3 x 3
320809	96 X 42	27600	3 x 3
320810	96 X 48	27600	3 x 3
320813	120 X 42	27600	3 x 3
320814	120 X 48	27600	3 x 3
320811	144 X 36	32900	3 x 3
320815	144 X 42	32900	3 x 3
320816	144 X 48	32900	3 x 3
320817	192 X 42	32900	3 x 3

TO ORDER:

Measure beam length between uprights (left-to-right)

Measure beam depth overall (front-to-back)

Measure depth between beam steps (front-to-back)

Beam Length"	Use	Beam Length"	Use
96	Two 46"	120	Two 58"
108	Two 52"	144	Three 58"



STEEL WIRE MESH DECKING

Strong 6-gauge gray baked-enamel finished wire decking features welded construction and 14-gauge channel supports. Unlike wood or metal decking, wire permits light, air, and sprinkler penetration; allows a clear view of upper tiers; and minimizes dust and debris accumulation. Easy installation—simply drop into place over beams. Use with beams that have 1¹/₂" or 1⁵/₈" step.

Model	Cap. Lbs.	Length Left/Right"	Depth Front/Back"	Between Step"
798651	2700	46	36	32 ¹ / ₂
798652	2750	52	36	32 ¹ / ₂
798653	2800	58	36	32 ¹ / ₂
798654	2500	46	42	38 ¹ / ₂
798655	2700	52	42	38 ¹ / ₂
798656	2750	58	42	38 ¹ / ₂
798657	2500	46	48	44 ¹ / ₂
798658	2500	52	48	44 ¹ / ₂
798659	2500	58	48	44 ¹ / ₂

RACK PROTECTORS

799047

These rack protectors provide impact-resistance against forklifts, pallet jacks, and dolly carts to prevent rack damage and content spillage. Flexible EVA polyethylene construction features an air chamber designed to deflect impact energy away from the rack for added structural protection. Finish improves rack visibility in dim environments for personnel safety. Dual hook-and-loop fasteners easily secure the protectors to racks.



Model	W" x D" x H"	Type	Column Size"
799047	5 ¹ / ₄ x 6 x 18	Standard Mount	3 x 3
799048	5 ¹ / ₄ x 6 x 18	Cutout for Beam	3 x 3
799049	5 ¹ / ₄ x 6 x 18	End Mount	3 x 3



EXTRA HEAVY-DUTY DIE RACK SHELVING

- 3000 lb shelf capacity
- Rigid 2" x 2" angle posts
- Enamel finish
- Heavy-gauge steel shelves with high weight capacity for heavy equipment and supply storage
- Reinforced with flanged channel construction adjust on 1" increments

5 SHELVES			
6'		8'	
W" x D"	Model	W" x D"	Model
36 x 18	236602	36 x 18	236632
36 x 24	236610	36 x 24	236640
48 x 18	236606	48 x 18	236636
48 x 24	236614	48 x 24	236644
60 x 18	236608	60 x 18	236638
60 x 24	236616	60 x 24	236646
72 x 24	236618	72 x 24	236648

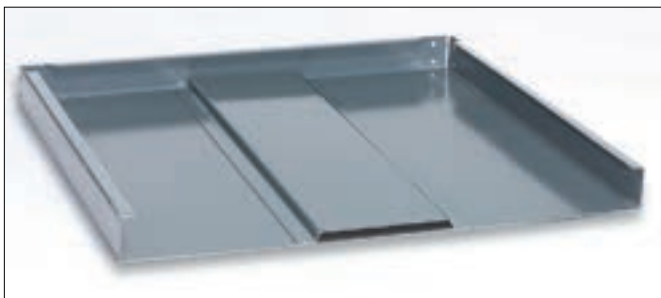

EXTRA SHELVES

- 3000 lb capacity
- Reinforced with flanged channel construction
- Adjusts on 1" increments
- Enamel finish

Model	W" x D" x H"
234CP119	36 x 18 x 2
234CP122	36 x 24 x 2
234CP120	48 x 18 x 2
234CP123	48 x 24 x 2
234CP121	60 x 18 x 2
234CP125	60 x 24 x 2
236678	72 x 24 x 2

Call us and start building the right shelving for you.

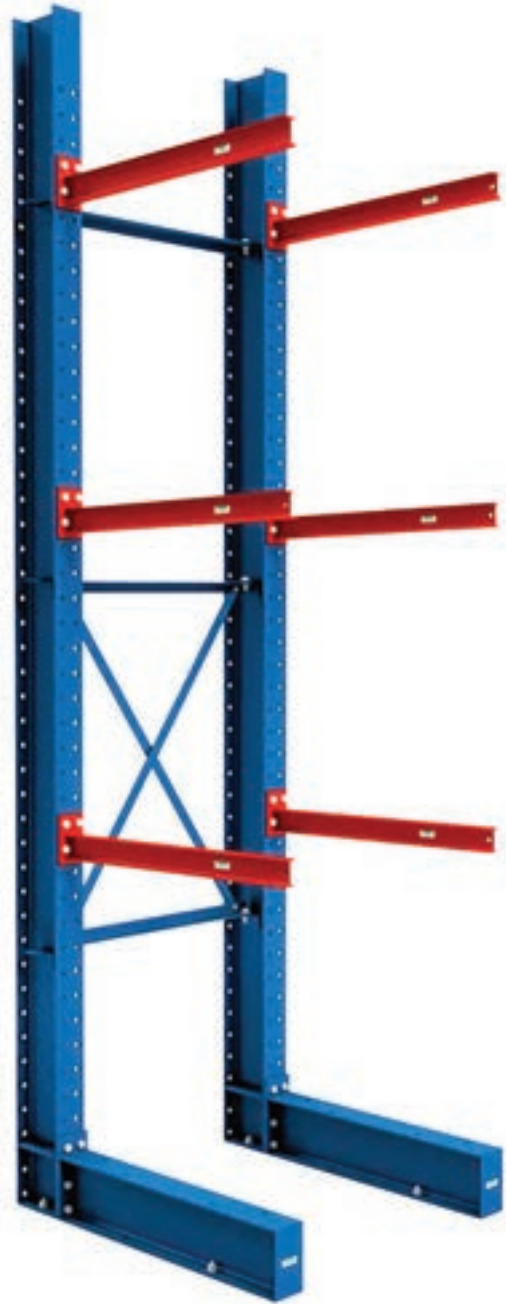

HEAVY-DUTY CANTILEVER RACK STARTERS

Solid steel, gray, single-sided rack supports medium-size loads of lumber, pipes, and other dense materials.

Model	Side Type	W" x D" x H'	Cap. Lbs.	Arm Length"	Arm Type	Arm Cap.	Arm Qty.
320821	Single	48 x 38 x 8	13300	24	No Lip	1200	8
320822	Single	48 x 38 x 8	13300	24	2" Lip	1200	8
320823	Single	72 x 50 x 10	10300	36	No Lip	800	10
320824	Single	72 x 50 x 10	10300	36	2" Lip	800	10
320825	Single	72 x 58 x 12	8500	48	No Lip	600	12
320826	Single	72 x 58 x 12	8500	48	2" Lip	600	12
320827	Double	48 x 60 x 8	26600	24	2" Lip	1200	16
320828	Single	48 x 33 x 6	5300	12	2" Lip	600	6
320829	Single	48 x 33 x 8	5300	12	2" Lip	600	8
320830	Double	48 x 60 x 8	20800	24	2" Lip	1300	16

I-BEAM CANTILEVER RACK STARTERS

I-Beam cantilever rack saves horizontal space, reduces fork truck damage, and allows for faster load and unload times. Constructed of structural steel with a 50,000 PSI minimum yield. Arms adjust vertically in 4" increments. Heavy arm connector plate and bolted column-to-base connections. Capacity based on 36" arm spacing.

Model	Side Type	W" x D" x H'	Cap. Lbs.	Arm Length"	Arm Cap.	Arm Qty.
B2366078	Single	72 x 58 x 16	18530	48	2600	8
B2366080	Single	48 x 58 x 16	18530	48	2600	8
B2366082	Single	72 x 56 x 12	13010	48	2600	6
B2366085	Single	48 x 56 x 12	13010	48	2600	6
B2366068	Double	72 x 106 x 16	18530	48	2600	16
B2366072	Double	48 x 106 x 16	18530	48	2600	16
B2366074	Double	72 x 104 x 12	13010	48	2600	12
B2366076	Double	48 x 104 x 12	13010	48	2600	12



EXTRA HIGH-CAPACITY BULK RACKS WITH WOOD DECK

Cost-effective, heavy-duty metal storage racks to handle hand-loaded materials. 5/8" thick particle wood deck and 5 deck supports per level. Almost twice the capacity per level as standard bulk racks thanks to the 14-gauge formed step-beam frame. Beams attach to frame in seconds without tools.

Model	W" x D" x H"	Cap. Lbs.
504283	60 x 48 x 72	3800
504282	60 x 36 x 72	3800
504281	60 x 24 x 72	3800
504590	60 x 18 x 72	3800
504286	72 x 48 x 72	2750
504285	72 x 36 x 72	2750
504284	72 x 24 x 72	2750
504536	72 x 18 x 72	2750
504537	96 x 18 x 72	2150
504289	96 x 48 x 72	2150
504288	96 x 36 x 72	2150
504287	96 x 24 x 72	2150
504292	60 x 48 x 96	3800
504291	60 x 36 x 96	3800
504290	60 x 24 x 96	3800
504295	72 x 48 x 96	2750
504294	72 x 36 x 96	2750
504293	72 x 24 x 96	2750
504298	96 x 48 x 96	2150
504297	96 x 36 x 96	2150
504296	96 x 24 x 96	2150



Three hooks for positive connection



EXTRA HIGH-CAPACITY BULK RACKS WITH WIRE DECK

Cost-effective, heavy-duty metal storage racks to handle hand-loaded materials. High-strength wire deck and 5 deck supports per level. Almost twice the capacity per level as standard bulk racks thanks to the 14-gauge formed step-beam frame. Beams attach to frame in seconds without tools.

Model	W" x D" x H"	Cap. Lbs.	Model	W" x D" x H"	Cap. Lbs.
504464	60 x 24 x 72	3800	504471	96 x 36 x 72	2150
504466	60 x 48 x 72	3800	504472	96 x 48 x 72	2150
504542	72 x 18 x 72	2750	504473	60 x 24 x 96	3800
504467	72 x 24 x 72	2750	504476	72 x 24 x 96	2750
504468	72 x 36 x 72	2750	504477	72 x 36 x 96	2750
504469	72 x 48 x 72	2750	504478	72 x 48 x 96	2750
504543	96 x 18 x 72	2150	504480	96 x 36 x 96	2150
504470	96 x 24 x 72	2150	504481	96 x 48 x 96	2150



798922

798922



798922

PORTABLE STACK RACKS

Stacking storage racks provide a convenient, economical alternative to pallet racks. These forkliftable storage racks accept pallet storage or can be used as a pallet itself. Base allows 4-way forklift access for portability even when loaded. When stacked, storage racks eliminate load-on-load contact. Easy modular assembly. Blue enamel finish.

Model	W" x D" x H"	Cap. Lbs.
798925	48 x 42 x 48	4000
798924	48 x 42 x 36	4000
798923	48 x 48 x 36	4000
798922	48 x 48 x 48	4000
798927	60 x 42 x 48	4000
798926	60 x 42 x 36	4000
272151	48 x 48 x 60	4000



798899

VERTICAL BAR RACK

Ideal for storing pipes, lumber, and other long materials, this bar storage rack has a 3000 lb. capacity. Long pieces stack vertically in one of three 10"W storage bays; shorter pieces are stored on the 3 pan shelves. Blue finish. Includes a safety chain to retain contents. Easy assembly.

Model	W" x D" x H"	Cap. Lbs.
798925	39 x 24 x 84	3000

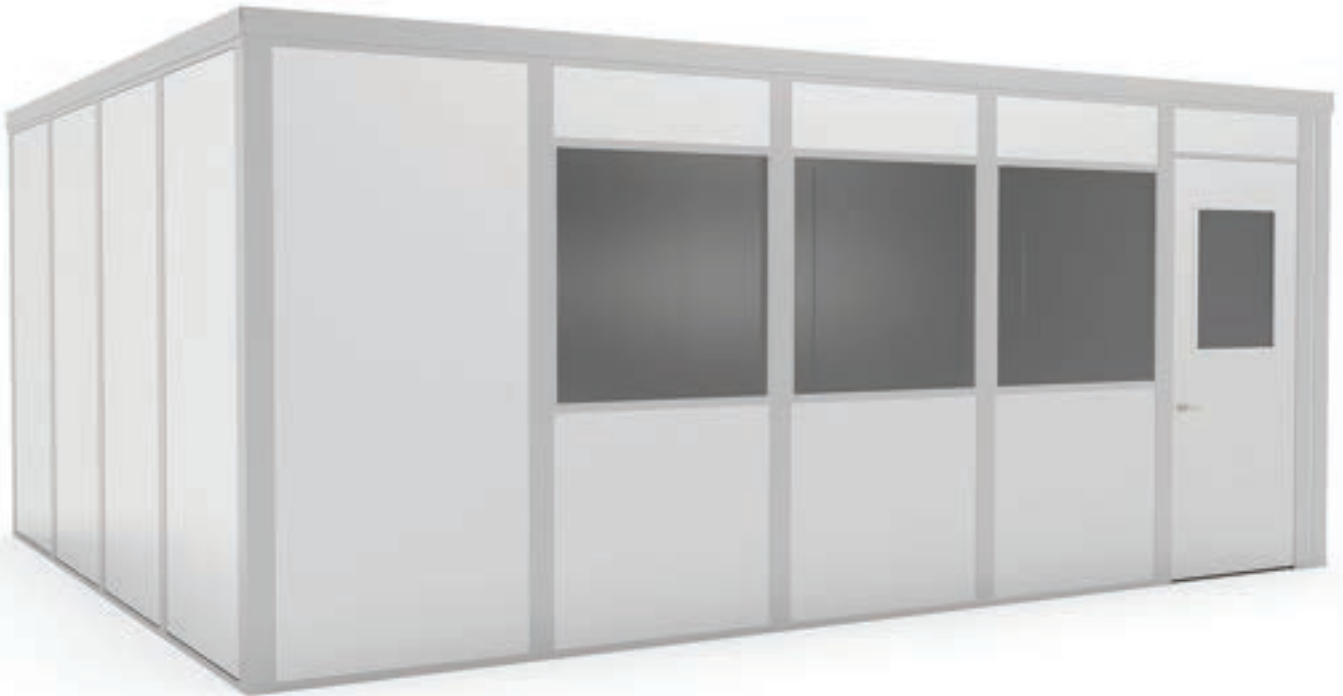

DESIGN YOUR NEW MODULAR OFFICE

Easily add office space inside your building.

MODULAR INPLANT OFFICES

Create cost-effective office spaces anywhere. Each unit features a four-wall enclosure with prefinished vinyl-covered drywall laminated to a solid EPS core for high-level sound control and thermal insulation. Most models have a recommended clearance height of 9' to ensure the metal roof deck can be easily installed.



CLASS C				CLASS A			
Model	W' x D' x H'	Light Fixtures	Outlets	Model	W' x D' x H'	Light Fixtures	Outlets
B2688570	10' x 10' x 8'2"	1	(3) 115V Duplex	B2688575	10' x 10' x 8'2"	1	(3) 115V Duplex
B2688571	10' x 12' x 8'2"	2	(3) 115V Duplex	B2688576	10' x 12' x 8'2"	2	(3) 115V Duplex
B2688572	10' x 16' x 8'2"	2	(4) 115V Duplex	B2688577	10' x 16' x 8'2"	2	(4) 115V Duplex
B2379097	12' x 12' x 8'2"	2	(4) 115V Duplex	B2379091	12' x 12' x 8'2"	2	(4) 115V Duplex
B2379094	12' x 16' x 8'2"	2	(4) 115V Duplex	B2379090	12' x 16' x 8'2"	2	(4) 115V Duplex
B2688573	12' x 20' x 8'2"	2	(5) 115V Duplex	B2688578	12' x 20' x 8'2"	2	(5) 115V Duplex
B2688574	16' x 20' x 8'2"	3	(6) 115V Duplex	B2688579	16' x 20' x 8'2"	3	(6) 115V Duplex
B2379098	8' x 10' x 8'2"	1	(3) 115V Duplex	B2379095	8' x 10' x 8'2"	1	(3) 115V Duplex
B2379100	8' x 12' x 8'2"	2	(3) 115V Duplex	B2379093	8' x 12' x 8'2"	2	(3) 115V Duplex
B2379099	8' x 16' x 8'2"	2	(3) 115V Duplex	B2379092	8' x 16' x 8'2"	2	(3) 115V Duplex
B2379101	8' x 8' x 8'2"	1	(3) 115V Duplex	B2379096	8' x 8' x 8'2"	1	(3) 115V Duplex



WILDECK® INDUSTRIAL STEEL MEZZANINES

Fully utilize existing overhead space, so you can operate more efficiently and profitably. Gain valuable working, office, storage, or manufacturing areas at a fraction of the cost of new construction. Put this space to work fast, with minimal interruption to your working floor area. All units meet OSHA, BOCA, UBC, and ADA standards.

Model	W x D x H	Sq. Ft.
B2002334	11' x 31'-5" x 10'	346.5
B2002332	11' x 31'-5" x 8'	346.5
B2002333	11' x 31'-5" x 9'	346.5
B2002322	16' x 11' x 8'	176
B2002324	16' x 11' x 10'	176
B2002323	16' x 11' x 9'	176
B2002327	16' x 21'-7" x 10'	336
B2002325	16' x 21'-7" x 8'	336
B2002326	16' x 21'-7" x 9'	336
B2002337	21'-7" x 31'-5" x 10'	677.25
B2002335	21'-7" x 31'-5" x 8'	677.25
B2002336	21'-7" x 31'-5" x 9'	677.25
B2002328	31'-5" x 16' x 10'	504
B2002320	31'-5" x 16' x 8'	504
B2002321	31'-5" x 16' x 9'	504
B2002342	32'-2" x 31'-5" x 10'	1013.355
B2002338	32'-2" x 31'-5" x 8'	1013.355
B2002341	32'-2" x 31'-5" x 9'	1013.355

RAISE THE DECK WITHOUT RAISING A FUSS WITH MEZZANINES



EQUIPTO MEZZANINE WITH SOLID STEEL GRATING DECK

8' by 12' mezzanine; 8' in height with safety-yellow railings, a lift gate and a 48" wide OSHA-compliant stairway with a 4'x4' landing. Deck is solid steel grating.



798929

MEZZANINE SAFETY GATE

Allows easy and safe access to mezzanines using manual swing-action gates on each end. Balanced for ease of operation without use of springs. Mezzanine safety gate is made of heavy-duty welded steel. Meets OSHA requirements. 68½"W x 76"D x 79½"H.



UNEX PROVIDES UNIQUE SOLUTIONS FOR MOVING AND STORING PRODUCTS OF ALL SIZES



FLOW CELL HEAVY-DUTY GRAVITY RACK WITH WHEELBED STARTER

This unit has a SpanTrack wheelbed that allows front-feeds to keep products at pick point. Uprights and beams are made from powder-coated tube steel with welded plates for floor-mounting. Low-friction wheels for easy mobility with 1000-lb. capacity per level.



31229022

SPANTRACK GRAVITY FLOW ROLLER LANE

This roller track drops onto a standard rack's step beams to create gravity-flow shelving that maximizes inaccessible space, minimizes loading time, and ensures stock rotation. Aluminum rollers with galvanized steel tracks ensure durability, and no tools are required for installation. 42"D x 12"W, 50-lb. capacity.



30106439

SPEEDCELL BAY

Designed to maximize pallet rack space, the Speedcell Bay improves access and accommodates smaller items like apparel and open cases. The columns are corrosion- and fire-resistant and the whole system easily fits most pallet racks. 96"W x 42-48"D x 86"H; 84 cells.



32313522

PALLET TRACK STEEL FLOOR CONVEYOR

Ideal for fast-moving SKUs picked straight from the pallet. 96" long x 50" overall width, the track includes front ramp stops, fixed-angle rear-end stops, with mid- and rear-floor supports. 2 lanes, 8' L, 8000 lb. cap.

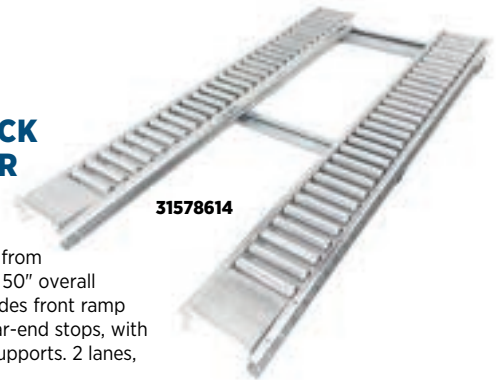

31578614

MOVE AND STORE WITH PERFECT STORAGE SOLUTIONS

FLOW CELL MOBILE PICK TRAY RACK

For use with Mobile Flow Rack-Style Storage Racking. Includes 3 tilted shelves, 4"x2" swivel casters with side brake, 3000 lb./unit capacity, 1000 lb./level, 76"W x 28" D x 72"H.



31229028



390205

653179



EXCLUSIVE BRANDS

10,000 LB. HIGH-CAPACITY REEL RACKS

10,000 lb. high-capacity reel racks adjust to hold spools that measure up to 60" in diameter. The axle brackets accommodate up to 2" diameter axles for a 2000 lb. capacity per pair. Safety pins lock the axle brackets and cross beams to the 12-gauge steel upright frames. 10-gauge steel axle brackets attach to lapped and welded beams with three hooks for a positive connection. The cross beams and brackets adjust on 3" centers for large or small reels. Should be secured to floor.

Model	W" x D" x H"
653177	24 x 24 x 120
653171	24 x 24 x 96
653174	24 x 36 x 96
653178	36 x 24 x 120
653172	36 x 24 x 96
653180	36 x 36 x 120
653175	36 x 36 x 96
653179	48 x 24 x 120
653173	48 x 24 x 96
653181	48 x 36 x 120
653176	48 x 36 x 96

EXCLUSIVE BRANDS

REEL RACKS

Sturdy steel reel storage racks feature 6 levels that can hold up to 3 axles each. Can be customized to hold a total of 18 axles. The boltless construction is easy to assemble and allows tool-free level adjustment. Secures to walls or floors for maximum stability and is finished in a chip-resistant baked enamel for lasting durability.

Model	W" x D" x H"
Mount Rack	
390205	36 x 24 x 84
390213	48 x 24 x 84
ADDITIONAL AXLE BRACKETS With 1/2" Axle	
390206	36"W
968555	48"W
ADDITIONAL AXLE BRACKETS With 3/4" Axle	
968556	48"W
ADDITIONAL AXLE BRACKETS With 13/16" Axle	
390207	36"W

TRESTON

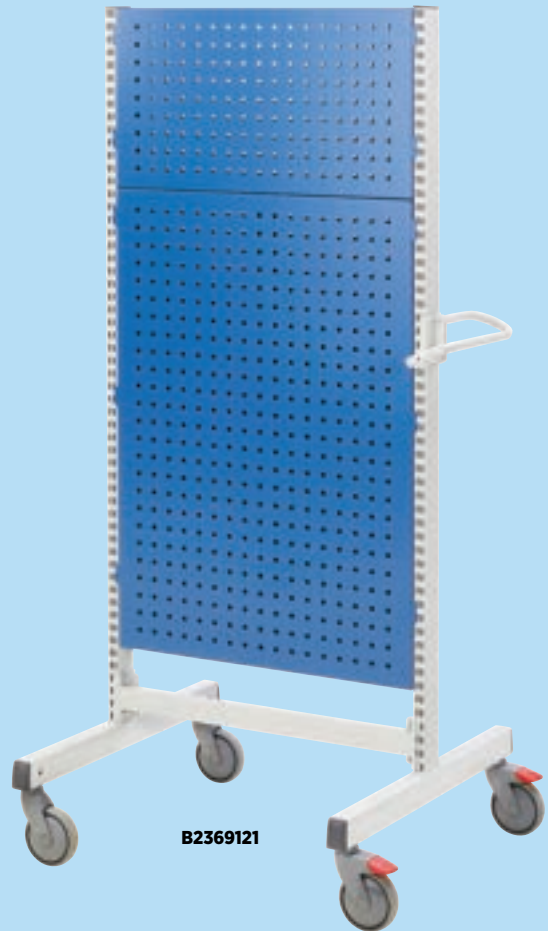

B2369121

MOBILE PANEL CART

Tools and parts/equipment can be easily transported to the workspace, saving time and improving efficiency. Multiple configuration options allow it to be customized to each job. 4 peg-board panels included with optional hooks and other accessories sold separately. 660 lbs. total load capacity, 36"W x 30"D x 70.5"H cart dimensions. Four 5" swivel casters, two with brakes.

HOW TO CHOOSE THE PERFECT SHELVING

These simple tips can help you choose the perfect shelving system for you, your products, and your business—while staying on-budget without compromise.







CHOOSE YOUR FINISH

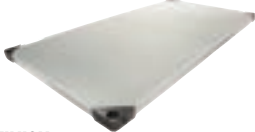
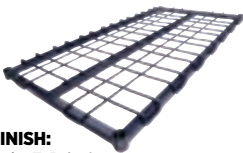

	CHROME	BLACK EPOXY	SILVER EPOXY	POLY-GREEN®	POLY-Z-BRITE®	STAINLESS STEEL	NEXELON®
Dry Storage	•	•	•	•	•	•	•
Wet Storage		•	•	•	•	•	•
Cooler Storage		•	•	•	•	•	•
Freezer Storage		•	•	•	•	•	•
Warranty	Limited 1-Year	Limited 7-Year	Limited 7-Year	Limited 15-Year	Limited 15-Year	Limited Lifetime	Limited Lifetime

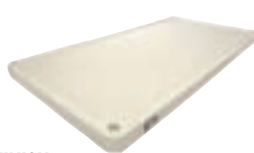
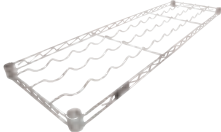
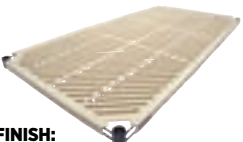
CHOOSE YOUR SHELVING TYPE

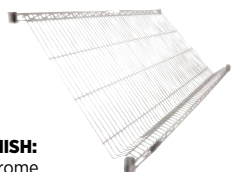
STANDARD	SOLID STEEL	HEAVY-DUTY/DUNNAGE	QUICK ADJUST	SOLID PLASTIC
 <p>FINISH: 7 Finishes</p> <p>CAPACITY: 600 to 800 lbs.</p>	 <p>FINISH: 18 Ga. Galvanized or 304 Stainless Steel</p> <p>CAPACITY: Up to 600 lbs.</p>	 <p>FINISH: Poly-Z-Brite® or Nexelon®</p> <p>CAPACITY: 1000 to 1600 lbs.</p>	 <p>FINISH: Chrome or Poly-Z-Brite®</p> <p>CAPACITY: 400 lbs.</p>	 <p>FINISH: Plastic</p> <p>CAPACITY: 300 lbs.</p>
WINE CRADLE	NEXELITE®	WIRE BASKET	SLANT	
 <p>FINISH: Chrome or Black Epoxy</p> <p>CAPACITY: 100 lbs.</p>	 <p>FINISH: Polymer Mats with Nexelon® Frames</p> <p>CAPACITY: 325 to 400 lbs.</p>	 <p>FINISH: Chrome</p> <p>CAPACITY: 300 lbs.</p>	 <p>FINISH: Chrome</p> <p>CAPACITY: 400 lbs.</p>	

CHOOSE YOUR SIZE

SHELVES:

From 12"-36" Deep
From 24"-72" Wide

LEVELS:

How many levels do you need?

POSTS:

From 6"-96" High

CHOOSE YOUR ACCESSORIES



NEXEL WIRE LEDGE



NEXEL DIVIDER



NEXEL STEM CASTERS



NYLON COVER

FIND YOUR PERFECT SHELVING

Once you've decided what you need, find it here. There are many possible configurations.

OUR MOST POPULAR SHELVING OPTIONS



NEXEL® QUICK-ADJUST WIRE SHELVING

- Bright, nickel-chrome creates a brilliant high-gloss finish
- Quick-adjust suspension hooks allow middle shelves to be adjusted, added, or removed without tools
- Includes 4 posts, 2 fixed shelves, 2 Quick adjust shelves, 8 suspension hooks, and snap-on sleeves
- Quick-adjust 400-pound shelf capacity; fixed shelves 600 to 800-pound shelf capacity
- NSF-approved for dry use
- Limited 1-year warranty in dry application and usage

Model	W" x D" x H"
580570	36 x 24 x 74
580571	48 x 24 x 74
580572	60 x 24 x 74
580573	72 x 24 x 74



NEXEL® SOLID PLASTIC SHELVING

- Raised edge to prevent spills
- Includes 4 posts, 4 shelves, and snap on sleeves
- 300-pound shelf capacity
- NSF-approved for wet or dry use
- Poly-Z-Brite® posts have limited 15-year warranty against rust and corrosion

Model	W" x D" x H"
188124	36 x 18 x 63
188125	48 x 24 x 63



NEXELITE® VENTED PLASTIC MAT SHELVING

- Polymer composite shelf mats
- Frame and posts in Nexelon® finish
- Open design to maximize air and light circulation and minimize dust accumulation
- Includes 4 posts, 4 shelves, and snap-on sleeves
- 325 to 400-pound shelf capacity
- NEXGuard® an antimicrobial agent protects the epoxy coating from bacteria, mold, and mildew that causes odors and product degradation
- NSF-approved for wet or dry use
- Limited lifetime warranty against rust and corrosion

Model	W" x D" x H"
331530N	36 x 24 x 63
331531N	48 x 24 x 63
331532N	60 x 24 x 63
331533N	72 x 24 x 63

188428



Bright, chrome-over-nickel electroplating creates a brilliant high-gloss finish. Limited 1-year warranty in dry application and usage

990143



Nexelate features an attractive finish that consists of a Silver Epoxy powder coat over a rust-inhibiting undercoat. Limited 7-year warranty against rust and corrosion

189218



Poly-Z-Brite features a true powder-epoxy over zinc-chromate electroplating that ensures a strong durable finish and handles temperature and moisture extremes well. NEXGuard, an anti-microbial agent, protects the epoxy coating from bacteria, mold, and mildew that causes odors and product degradation. Limited 15-year warranty against rust and corrosion.

B1137261



Poly-Green is designed with a powder coated green epoxy finish that handles temperature and moisture extremes well. NEXGuard, an anti-microbial agent, protects the epoxy coating from bacteria, mold, and mildew that causes odors and product degradation. Limited 15-year warranty against rust and corrosion



NEXEL® WIRE SHELVING

- Reinforced shelves with welded surface ribs for added strength
- Open design to maximize air and light circulation and minimize dust accumulation
- Includes 4 posts, 4 shelves, and snap-on sleeves
- Shelves easily adjust without tools at 1" increments
- 600-800 pound shelf capacity
- NSF-approved

189412



Stainless steel features a smooth, attractive, electro-polished finish are designed to handle extreme wet, hot or cold environments. Limited lifetime warranty against rust and corrosion.

188420E



Nexelon is the top of the line blue metallic finish designed to handle extreme wet, hot or cold environments. NEXGuard, an anti-microbial agent, protects the epoxy coating from bacteria, mold, and mildew that causes odors and product degradation. Limited lifetime warranty against rust and corrosion.

B970200



Black epoxy features an attractive, rugged and affordable finish ideal for offices, retail stores, warehouses and more. Limited 7-year warranty against rust and corrosion.

Model	Finish	L" x W" x H"
188428	Chrome	36 x 24 x 74
188430	Chrome	48 x 24 x 74
188432	Chrome	60 x 24 x 74
188434	Chrome	72 x 24 x 74
990143	Nexelate	36 x 24 x 74
990144	Nexelate	48 x 24 x 74
990145	Nexelate	60 x 24 x 74
990146	Nexelate	72 x 24 x 74
189218	Poly-Z-Brite	36 x 24 x 74
189220	Poly-Z-Brite	48 x 24 x 74

Model	Finish	L" x W" x H"
189222	Poly-Z-Brite	60 x 24 x 74
189223	Poly-Z-Brite	72 x 24 x 74
B1137261	Poly-Green	36 x 24 x 74
B1137275	Poly-Green	48 x 24 x 74
B1137277	Poly-Green	60 x 24 x 74
B1137278	Poly-Green	72 x 24 x 74
B970200	Black Epoxy	36 x 24 x 74
B970163	Black Epoxy	48 x 24 x 74
B970176	Black Epoxy	60 x 24 x 74
B970181	Black Epoxy	72 x 24 x 74
188420E	Nexelon	36 x 18 x 74
188422E	Nexelon	48 x 18 x 74
188424E	Nexelon	60 x 18 x 74
188426E	Nexelon	72 x 18 x 74
189412	Stainless	36 x 24 x 74
189414	Stainless	48 x 24 x 74
189516	Stainless	60 x 24 x 74
189518	Stainless	72 x 24 x 74

WIRE SHELVING TO SATISFY ALL OF YOUR NEEDS

All shelving units are fully customizable with add-on units, additional shelves, and accessories that include casters, liners, cart covers, ledges, dividers, label holders, and more.



168207

NEXEL® UTILITY CARTS

- Reinforced shelves with welded surface ribs for added strength
- Open design to maximize air and light circulation and minimize dust accumulation
- Includes 2 shelves, 2 U-handles, snap-on sleeves and polyurethane swivel casters
- Shelves easily adjust without tools at 1" increments
- 1200 pound shelf capacity
- NSF approved

Model	Finish	L" x W" x H"
188704	Chrome	36 x 18 x 39
188708	Chrome	36 x 24 x 39
168207	Nexelate	36 x 18 x 39
168208	Nexelate	36 x 24 x 39



B2351566

NEXEL® ESD WIRE SHELVING STARTERS

- Bright nickel-chrome electroplating creates a brilliant high-gloss finish
- Store electronics, circuit boards, and other static-sensitive materials
- Reinforced shelves with welded surface ribs for added strength
- Open design maximizes air and light circulation and minimizes dust accumulation
- Includes 4 posts, 3 shelves, aluminum shelf clips, and ground chain
- Shelves easily adjust without tools at 1" increments
- 600-800 pound shelf capacity
- Limited 1-year warranty in dry application and usage

Model	W" x D" x H"
B2351566	24 x 14 x 34
B2351564	36 x 14 x 34
B2351977	24 x 18 x 34
B2351975	36 x 18 x 34



B2378892

500591

AL460GZ

NEXEL® WIRE SHELVING ACCESSORIES

- Poly-Green® powder coat epoxy finish withstands temperature & moisture extremes
- Installs easily without the use of bolts, nuts, or clips
- NEXGard® antimicrobial agent protects the epoxy coating from bacteria, mold, and mildew
- 1200-pound capacity
- NSF-approved for wet or dry use
- Limited 15-year warranty against rust and corrosion
- Polyurethane casters available in swivel with brake or rigid

Model	Sizes
B2378892	24"D x 8"H
AL424GZ	24"W x 4"H
AL436GZ	36"W x 4"H
AL448GZ	48"W x 4"H
AL460GZ	60"W x 4"H
AL472GZ	72"W x 4"H
500591	5" Diameter
500592	5" Diameter



NEXEL® SOLID SHELVING

- Raised lip surrounding the edge of each shelf to prevent spills from overflowing
- Open design allows shelves to be reached from all sides
- Includes 4 posts, 4 shelves, and snap on sleeves
- Shelves easily adjust without tools at 1" increments
- 400-600 pound shelf capacity

Model	Finish	L" x W" x H"
189934	Galvanized	36 x 24 x 74
189935	Galvanized	48 x 24 x 74
189936	Galvanized	60 x 24 x 74
189937	Galvanized	72 x 24 x 74
235363	Stainless	36 x 18 x 74
797092	Stainless	48 x 18 x 74



CABINETS

- Industrial-strength cabinets are designed to meet your storage needs—including janitorial see-thru doors, ventilated, combination, and general storage
- Multiple colors, width, depth, and height options
- Most cabinets are offered as unassembled or pre-assembled

Model	W" x D" x H"	Style	Color	Assembly
269903BK	36 x 18 x 72	Janitorial	Black	Assembled
269873GY	36 x 24 x 42	Counter Height	Gray	Assembled
237621GY	48 x 24 x 78	Clear View	Gray	Assembled
603600GY	48 x 24 x 78	Storage Cabinet	Gray	Assembled
269879TN	36 x 18 x 72	Combination Cabinet	Tan	Assembled

FIND YOUR PERFECT STORAGE CABINET



B2169507

EXTRA HEAVY-DUTY STORAGE CABINETS

- Extra heavy-duty storage for heavy, bulky, and/or high-value items
- All-welded cabinets are ideal for applications requiring a tough exterior, high security, and high-capacity shelves
- These cabinets offer a variety of storage options, from general storage, double shift, pegboard, and shelf with drawer combinations

Model	W" x D" x H"	Adj. Shelves	Shelf Cap. Lbs.
B2169507	48 x 24 x 72	4	1200
316056	48 x 24 x 42	4	1050
316062	60 x 24 x 78	4	1450

EXCLUSIVE BRANDS



298450BK

MODULAR DRAWER CABINETS

- Modular drawer cabinets offer the highest density of storage in the smallest square footage
- Organize and secure valuable tools, parts, and assemblies easily in every drawer with optional divider kits
- All-welded cabinets with drawers that fully extend using side-mounted drawer guides
- **Blue (BL)** or **Black (BK)** color finish.

Model	Dimensions"	Mobility	Drawers HT"	Draw Qty.
298448	30 x 27 x 37	MOBILE	(4) 3 x (2) 4 x (1) 6	7
493360	30 x 27 x 29½	STATIONARY	(4) 3 x (2) 4 x (1) 6	7
298450	36 x 24 x 57	STATIONARY	9(6)	9

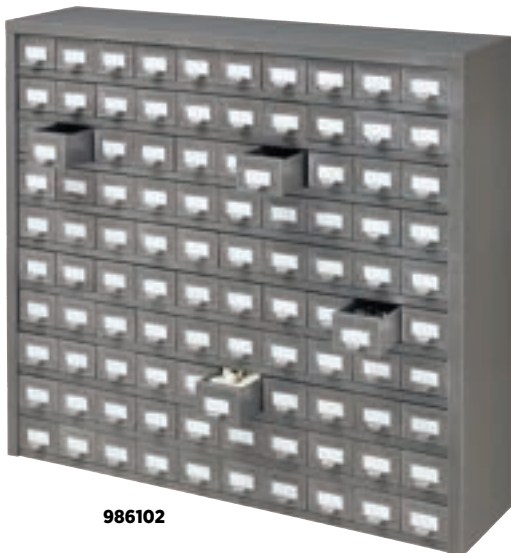

986102

MULTI-DRAWER CABINET

- Welded steel construction, assembled and ready-to-use
- Smooth-gliding 3"W x 8"D x 2-½"H drawers with drawer stops
- 36"W x 9"D x 34½"H
- Drawers : 100



316087

STAINLESS STEEL WALL- & COUNTER-HEIGHT CABINETS

- Affordable stainless steel cabinet
- Constructed of 18-gauge, type 304 stainless steel
- This fully-welded cabinet is ideal for restaurants, washdown, and cleanroom environments
- Resists acid, corrosion, and rust
- Ideal for any environment where a low-maintenance cabinet is needed

EXCLUSIVE BRANDS



237635BK

STORAGE CABINET

- Easiest set up of a cabinet, with just 4 screws
- Industrial-grade cabinet with a recessed handle

Model	W" x D" x H"	Color
237635BK	36 x 18 x 72	Black
237635GY	36 x 18 x 72	Gray
237635TN	36 x 18 x 72	Tan

EXCLUSIVE BRANDS



298541

FLAMMABLE CABINETS

These cabinets exceed NFPA, OSHA, and FM standards for securing and storing flammable liquids and protecting them in case of a fire. Two door options: manual and self-close. Local/state ordinances may require self-close cabinets.

Model	W" x D" x H"	Door Type	Gal. Cap.	Adj. Shelves
298670	17 x 18 x 22	Manual Close	4	1
298541	43 x 18 x 65	Manual Close	45	2
298601	43 x 18 x 65	Self Close	45	2
237777	59 x 35 x 65	Manual Close	120	2

EXCLUSIVE BRANDS



316105

DRUM STORAGE SAFETY CABINET

- Vertical drum storage safety cabinets, manual close
- Quickly and easily load drums into cabinet using the drum rollers
- Meets NFPA Code 30; OSHA-, UFC-, and EPA-compliant
- Capacity: 110-gallons



116037

WALL-MOUNT CYLINDER BRACKET

- Cylinder bracket easily mounts to a permanent vertical surface
- Keeps your gas cylinders securely stored
- Supports single cylinders from 3½" to 12½" in diameter

EXCLUSIVE BRANDS



CYLINDER STORAGE CABINET

- 14-gauge steel top and bottom with expanded metal doors and sides provide security along with ventilation and visibility of contents
- Yellow powder coat finish resists rust and acid corrosion
- Manual-close doors

Model	W" x D" x H"	Style	Cylinder Cap.
270257	60 x 30 x 65	Horizontal & Vertical	8 Horizontal/9 Vertical

EXCLUSIVE BRANDS

VOLATILE CHEMICAL STORAGE CABINETS

- all welded, double walled 18 gauge steel with 1½" air space and dual 2" diameter capped vents with flame arrestors.
- Doors are double walled with 14 gauge outside and 18 gauge inside
- Meets or exceeds NFPA and OSHA requirements. FM approved.



316067

Model	W" x D" x H"	Gal. Cap.	Adj. Shelves	Type
316067	43 x 18 x 65	45	2	Acid Corrosive
316063	43 x 12 x 44	24	3	Paint & Ink

ELECTRONIC LOCKER SYSTEM— SAFETY & SECURITY AT THE TOUCH OF A KEYPAD

Global Industrial™ Digital Lockers are ideal for breakrooms, gyms, schools, offices, hotels, hospitals, and other applications requiring secure access to stored contents. Each Digital Locker comes pre-assembled with a Global Industrial™ Electronic Vertical Keypad Lock and Master Key for added security, versatility, and convenience.

6-TIER DIGITAL BOX LOCKER

- Engineered to provide years of heavy-duty service
- 16-gauge steel doors, 5-knuckle security hinge and welded, reinforced frame-and-door assemblies for maximum security
- Padlockable friction latch and hasp closure
- Extra-wide louvers promote ventilation
- Includes the attached Global Industrial™ Electronic Vertical Keypad Lock with Master Key, which easily adds premiere-level security to the locker
- Specify color suffix: Gray(GY), Blue(BL) and Tan(TN)



WB652055GYDL

Model	W" x D" x H"	Wt Lbs.	Doors	Overall Width"
Single Tier				
WB652054GYDL	12 x 12 x 78	54	6	12
Triple Tier				
WB652055GYDL	36 x 12 x 78	161	18	36

Sleek, low-profile design to match any décor

Mountable vertical keypad for easy installation on flat surfaces

Digital electronic lock with level handle provides security and convenience

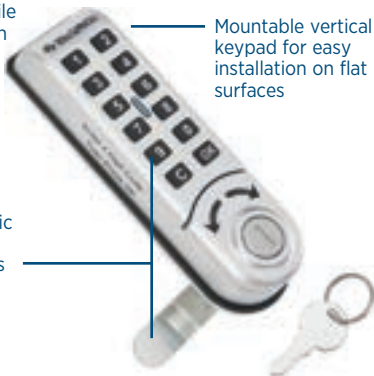

WB493722

ELECTRONIC VERTICAL KEYPAD LOCK WITH MASTER KEY

- Perfectly designed for compatible Global Industrial™ Lockers (models 652060GY - 652054TN)
- Pre-programmed, allowing for a quick setup
- Compatible with single, double, 3-tier, 4-tier, and 6-tier lockers
- Features a default mode for single passcodes and private mode for long-term individual use
- Ideal for lockers in gyms and hotels

Keep it safe and secure. We offer a broad portfolio of lockers and accessories designed to meet the needs of most any industry or application.



**RECESSED
STAINLESS
STEEL
HANDLE FOR
SAFETY AND
APPEARANCE**

INFINITY® LOCKERS

- Designed for improved safety, security, and appearance
- Door handle features a recessed latch in the door face to create a smooth catch-free surface that discourages the padlock from being cut off
- 5-knuckle security hinges and welded, reinforced frame-and-door assemblies for maximum security and long-lasting durability
- Extra-wide louvers promote ventilation
- Choice of easy-to-assemble or pre-assembled
- Specify color suffix: Gray(GY), Blue(BL) and Tan(TN)

READY TO ASSEMBLE Model	ASSEMBLED Model	W" x D" x H"	Wt. Lbs.	Doors	Overall Width"
Single Tier					
254122	968263	15 x 18 x 72	181	3	45
Double Tier					
254124	968265	12 x 12 x 36	153	6	36
Triple Tier					
493414	493424	12 x 15 x 24	161	9	36



**Chrome
door latch
for smooth
fingertip
opening**

PARAMOUNT® LOCKERS

- Ensure content security for gymnasiums, schools, employee areas, and more
- Door handle features chrome latch for smooth opening
- 5-knuckle security hinge and welded, reinforced frame-and-door assemblies for maximum security and long-lasting durability
- Extra-wide louvers on door to promote ventilation
- Choice of easy-to-assemble or pre-assembled
- Specify color suffix: Gray(GY), Blue(BL) and Tan(TN)

READY TO ASSEMBLE Model	ASSEMBLED Model	W" x D" x H"	Wt. Lbs.	Doors	Overall Width"
Single Tier					
652060	652160	12 x 12 x 60	43	1	12
Double Tier					
652079	652179	12 x 18 x 36	172	6	36
Triple Tier					
238231	238234	12 x 15 x 24	161	9	36



BOX LOCKERS

- Engineered for years of heavy-duty service
- Door features a padlockable friction latch and hasp closure
- 5-knuckle security hinge and welded, reinforced frame-and-door assemblies for maximum security and long-lasting durability
- Louvers on the door promote ventilation
- Choice of easy-to-assemble or pre-assembled
- Specify color suffix: Gray(GY), Blue(BL) and Tan(TN)

READY TO ASSEMBLE Model	ASSEMBLED Model	W" x D" x H"	Wt. Lbs.	Doors	Overall Width"
16 PERSON					
239449	239450	12 x 18 x 12	168	16	69
Four Tier					
493472	493482	12 x 12 x 18	150	12	36
Six Tier					
652966	652970				
652967	652971	12 x 15 x 12	65	6	12



CAPITAL® LOCKERS

- Quiet operation and ample storage for locker rooms
- Door features a catch-free recessed handle
- Extra-wide louvers on door promote ventilation
- Choice of easy-to-assemble or pre-assembled
- Specify color suffix: Gray (GY) and Tan (TN)

READY TO ASSEMBLE Model	ASSEMBLED Model	W" x D" x H"	Wt. Lbs.	Doors	Overall Width"
Single Tier					
652041	652141	12 x 18 x 72	162	3	36
Double Tier					
652047	652147	12 x 15 x 36	149	6	36

EXCLUSIVE BRANDS



184105

WIRE MESH SECURITY CAGE LOCKER

- See-thru and secure storage for retail, factories, warehouses, and more
- Cages are made with a 3" x 2" x ¼" thick wire mesh
- Minimize dust accumulation and maximize visibility for simple inventory control
- Includes one height-adjustable shelf with 100 lb. capacity
- Double doors are welded to side panels and are flush against unit top. Door hinges swing open 270° for full access

Model	W" x D" x H"
184105	72 x 36 x 72
184083	36 x 24 x 36
184090	48 x 24 x 72



SHOWN WITH OPTIONAL ROOF

BULK TENANT STORAGE LOCKERS

- Ventilated design allows light, air and sprinkler penetration
- Features welded padlockable hasp and ergonomic door pull for added security
- Lockers are easily wall-mounted to eliminate need for locker back panel
- Eliminate clutter and allow for proper aisle space throughout common storage area
- Optional add-on units can easily be attached to starter locker to create multiple units side-by-side
- Optional roof secures locker ceiling to deter theft

W" x D"	Type	Starter	Add-On	Roof
3 x 3	Single Tier	442657	442658	442681
3 x 3	Double Tier	442669	442670	442681

DURABLE PROTECTION WITH STURDY STEEL LOCKERS



STEEL GEAR LOCKERS

- Made from heavy-duty 16-gauge steel for long-lasting durability and corrosion-resistance
- Includes full-width coat rod and hooks for added storage space
- Perforated side panels for ventilation and odor control
- Top cabinet and bottom foot locker for additional storage
- Locker with door has a recessed handle and hasp for added security

Model	Overall W" x D" x H"	Door
B2161081	24 x 24 x 72	Solid Door
B2160970	24 x 18 x 72	No Door

INFINITY® HEAVY-DUTY VENTILATED STEEL LOCKERS

- Made using heavy 16-gauge steel with diamond-shaped perforations for improved airflow
- Locker door features rubber bumpers on framing to ensure quiet operation
- Continuous piano hinges provide maximum security
- Recessed handle and finger-lift control create a clean neat appearance



Opening W" x D" x H"	Overall Width"	Door	Wt. Lbs.	Ready to Assemble Model	Assembled Model
Single Tier					
12 x 18 x 72	36	3	225	493145GY	493245GY
Double Tier					
12 x 18 x 36	36	6	242	493151GY	493251GY
Six Tier					
12 x 15 x 12	36	18	234	493156GY	493256GY

B192398



EMERGENCY RESPONSE ALL-WELDED EQUIPMENT LOCKER WITH DRAWER

- Built to last using all-welded 16-gauge steel body & 14-gauge door
- All components are made of galvanized corrosion-resistant sheet steel for superior durability
- Door features 3-point high-security latching handle
- Interior includes a coat rod, 2 single-prong hooks, and a side pocket in the wardrobe compartment
- 2 full-width shelves on top, security box, a partial shelf, and a single-prong hook in the left compartment
- Single-prong coat hook on door acts as utility belt hook
- Base drawer includes a large lockable storage drawer with laminated maple wood seat

Model	W" x D" x H"
B192398	24 x 24 x 72

269238



MILITARY GEAR STORAGE LOCKER

- Designed to store military gear using secure, durable, and guaranteed construction that lasts a lifetime
- All-welded, double-door lockers are ideal for your military gear storage needs
- Full-framed sides with 3/4" flattened expanded-metal encapsulated on all four sides for maximum strength and ventilation
- Doors are 14-gauge diamond-perforated steel and feature 3-point chrome latching handles and 13-gauge 3 1/2" 7-knuckle hinges for extra security
- Includes upper hat shelf, coat rod, 3-single hooks

Model	W" x D" x H"
269238	42 x 24 x 78

EXCLUSIVE BRANDS

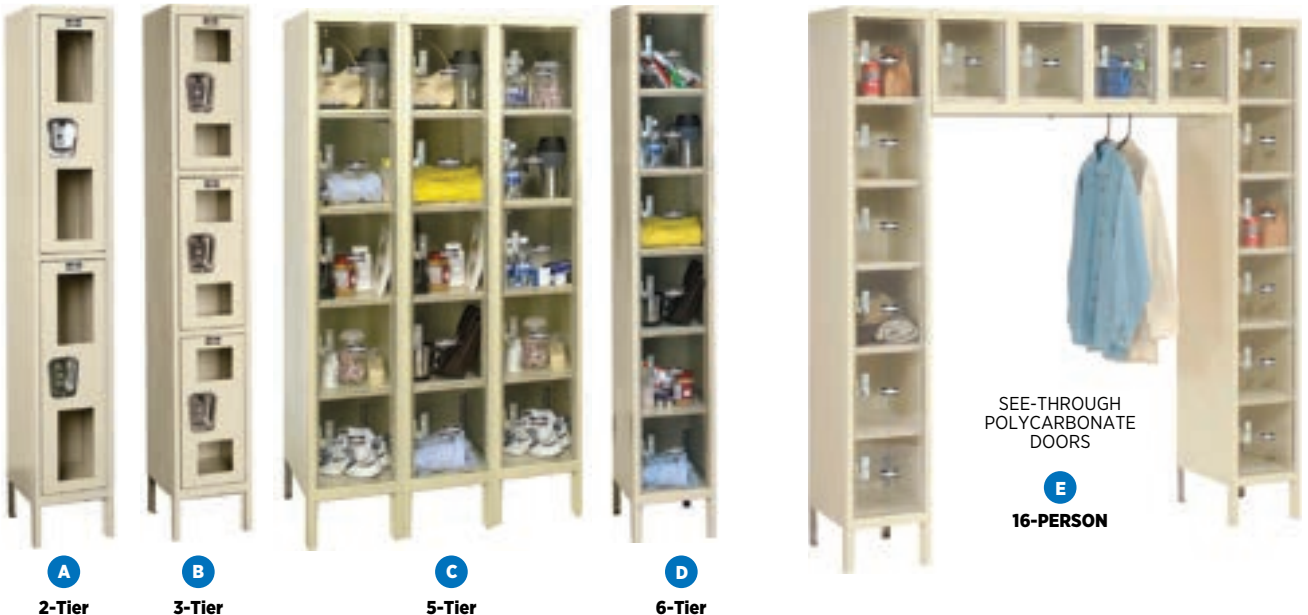

SEE-THROUGH POLYCARBONATE DOORS

E

16-PERSON

CLEAR-VIEW LOCKERS

- Doors are made of 16-gauge steel with transparent, scratch-resistant polycarbonate window
- 16-gauge steel locker frames for long-lasting durability, feature full-length continuous piano hinges for strength
- 2- and 3-tier locker doors are equipped with stainless steel recessed handles and padlockable gravity latches
- 5- and 6-tier, and 16-person lockers have padlockable friction latches

Opening W" x D" x H"	Tier	Door	Ready to Assemble Model	Assembled Model
A 12 x 15 x 36	2-Tier	6	B2311320	B2318171
B 12 x 18 x 24	3-Tier	9	B2311313	B2318158
C 12 x 12 x 12	5-Tier	15	B2311309	B2318154
D 12 x 12 x 12	6-Tier	18	B2311330	B2318166
D 12 x 15 x 12	6-Tier	18	B2311328	B2318165
D 12 x 18 x 12	6-Tier	18	B2311327	B2318163
E 12 x 18 x 12	16-Person	16	B2311326	B2318151



RUGGED ROTOMOLDED LOCKERS

- Rugged rotomolded lockers are rust- and corrosion-resistant for long-lasting use
- Withstand food service wash-downs
- Louvered double-walled doors
- Lockers are priced and ordered per opening
- The lockers can be joined back-to-back or affixed to the wall using optional mounting kit (sold separately, Model 652092)

Model	Tier	W" x D" x H"
652086	2-Tier	12 x 15 x 36
652088	4-Tier	15 x 15 x 18
238038	6-Tier	12 x 15 x 12

STAY SECURE WITH OUR EXTENSIVE LOCKER OPTIONS

EXCLUSIVE BRANDS



CELL PHONE LOCKERS

- Provide a convenient, secure, space-saving solution for storing electronic devices and personal items
- Can be mounted to the wall, or placed on any flat surface and fastened to a wall to prevent tipping
- Doors are equipped with both padlockable hasp and key lock
- One Master Key included for each unit to allow access to all locker doors compartments as needed
- Charging locker* has a USB port in each compartment for charging phones and other electronics using user's own charging cable

OVERALL W" x D" x H"	COMPARTMENT W" x D" x H"	OPENING W" x H"	Openings	Model
28 ⁷ / ₈ x 11 ¹ / ₄ x 28 ¹ / ₂	5 ⁹ / ₁₆ x 10 x 11 ¹ / ₂	5 x 10	8	493361BK*
32 ¹ / ₈ x 10 ¹ / ₈ x 46 ¹ / ₁₆	6 ¹ / ₁₆ x 8 ⁷ / ₈ x 6 ¹ / ₁₆	5 ⁹ / ₁₆ x 6 ¹ / ₁₆	24	493332BK
28 ¹ / ₂ x 11 ¹ / ₄ x 38	5 ⁹ / ₁₆ x 10 x 11 ¹ / ₂	5 x 10	12	493331BK
28 ¹ / ₂ x 11 ¹ / ₄ x 26 ³ / ₄	5 ⁹ / ₁₆ x 10 x 11 ¹ / ₂	5 x 10	8	493330BK
28 ¹ / ₂ x 11 ¹ / ₄ x 15 ⁵ / ₈	5 ⁹ / ₁₆ x 10 x 11 ¹ / ₂	5 x 10	4	493329BK



HIGH GRADE ABS PLASTIC LOCKERS

- Plastic lockers are constructed of water-resistant 1/4" thick high-grade plastic for long lasting durability and dependability in high-humidity areas
- Doors feature stainless steel hinges and hasps to accommodate optional padlock
- Gray finish with blue doors provides an attractive two-tone appearance
- Each compartment includes grooves that can accommodate up to 3 optional compartment shelves

OPENING W" x D" x H"	Door	Model
Double Tier		
12 ³ / ₄ x 18 x 36 ¹ / ₂	6	B1352610
Triple Tier		
12 ³ / ₄ x 18 x 24 ⁵ / ₁₆	9	B1352563
Four Tier		
12 ³ / ₄ x 18 x 18 ³ / ₄	12	B1352619

ORGANIZE YOUR WORKSPACE

A properly appointed and organized workspace is essential for productivity and safety. When there's a place for tools, equipment, parts, and other work essentials, employees and technicians can more easily find what they're looking, work faster and efficiently, and it reduces instances of ordering supplies that you actually have, but cannot see—affecting your bottom line with wasted time and money.

Key Benefits:

- Perfect for the production floor, materials management, supply rooms, workstations and tool crib
- Maximize floor, counter and wall space
- Control proper rotation of date-coded supplies
- An organized workspace reduces the risk of a trip and fall incident



Choosing the Perfect Bin

HANGING/STACKING BINS

Maximize wall and bench space while keeping work areas clean and organized. Most bins have front access for easier use when stacked.



SHELF BINS

Perfect for storing parts, stock, or tools on wire shelves, they maximize shelf space and improve organization, productivity, & efficiency. Stackable when empty for space-saving storage.

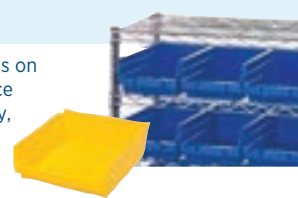

CORRUGATED CARDBOARD BINS

Available in a variety of sizes & styles, these bins offer organization on a budget. Replace as needed and use with non-oily items in dry areas.



DIVIDABLE GRID CONTAINERS

Enjoy flexible storage for small parts and components in a single bin with greater organization and stock control. Most are available with clear lids and ID holders.



4-SIDED CONTAINERS & TOTES

Available in a variety of configurations, models of the same size are stackable with their lids on and nest without lids. Options include with or without removeable lids and attached-lids.

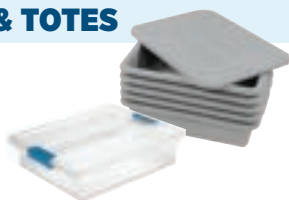

CONDUCTIVE BINS

Conductive bins are made of carbon-filled polypropylene and protect sensitive electronic components, like circuit boards, from damage caused by electrostatic buildup.



FIBERGLASS BINS

A step up in durability from standard plastic bins, fiberglass bins are ideal for use in extreme temperature conditions or with heavy parts. They are extremely strong and resilient.



STEEL BINS

Steel bins are the strongest bins available, and can stand up to extreme temperatures, hard use, and heavy parts without failing. These bins are made of channel-reinforced steel.



Let us help you choose the perfect solution to organize your workspace

PREMIUM STACK AND HANG BINS

- Made of FDA-compliant water- and corrosion-proof polypropylene, to withstand freezers and autoclaves from -40°F to 250°F
- Reinforced walls add strength; wide top ledge permits stable, higher stacking; full-width back hanger lip to hang on louvers
- Anti-slide stop prevents shifting when stacked
- Large front label slot for easy identification
- Black conductive bins are made with carbon-filled polypropylene, protects electronic components from static electricity and electromagnetic interference
- Tested to meet Mils Spec Mil-B-81075B, surface resistivity less than 105ohms/sq. when tested per ASTM D25
- Available in a wide range of sizes and colors
- Specify color suffix: Blue (BL), Yellow (YL), Red (RD), Beige (BG), Green (GN), Black (BK), or Clear (CL)



Overall W" x D" x H"	Ctn. Qty.	Model	Conductive Bin (Black) Model
4½ x 7¾ x 3	24	269681	184872
5½ x 10¾ x 5	12	269682	184873
11 x 10¾ x 5	6	269685	184875
8¼ x 14¾ x 7	12	269684	184877
16½ x 14¾ x 7	6	269686	184878



Yellow bins cups accessory sold separately. Model **550105YL**

PREMIUM SHELF BINS

- Designed for use on 12", 18", and 24"-shelving units and racks
- Nestable when empty to save storage space
- Wide hopper front for easy access, and wide label slot for clear identification
- Plastic bins are made of durable high-density polypropylene and are waterproof, chemical-, grease-, and oil-resistant
- Specify color suffix: Blue (BL), Yellow (YL), Red (RD), Green (GN), Stone (BG) and Clear (CL)

Overall W" x D" x H"	Ctn. Qty	Model
2¾ x 11½ x 4	24	184836
4½ x 11½ x 4	24	184837
6½ x 11½ x 4	12	184838
8½ x 11½ x 4	12	184843
11½ x 11½ x 4	12	184845

KEEP IT ORGANIZED WITH OUR PREMIUM BIN OPTIONS

PREMIUM GIANT STORAGE BINS

Giant plastic storage bins help to organize bulky items in warehouses, assembly lines, and maintenance areas. 24"-, 30"-, and 36"-deep Jumbo Hulk Bins and Magnum Bins

- Feature reinforced walls, adding strength and rigidity
- Wide top-ledge permits stable higher stacking
- Anti-slide stop prevents bins from shifting when stacked
- Rack bins are specifically designed to fit pallet racks
- Features 41¾" length to store large items and ensure full use of space on 42"D racks
- Base includes eight ¼" drill hole patterns for easy hole insertion that allows drainage and air circulation
- Mobile Giant bins* hold up 250 lbs.
- Move easily on 3" non-marring hard rubber swivel-casters with brakes



Overall W" x D" x H"	Ctn. Qty	Color	Model
16½ x 24 x 11	1	BL, RD, YL	238052
18½ x 29 x 11¾	1	BL, RD, YL, GN, BK	613120
18 x 28 x 15	1	BL, RD, YL, GN, BK	334202*
23¾ x 41¾ x 17½	1	Blue	B472273*



752397



652733

HEAVY-DUTY HOPPER BINS

- Heavy-duty hopper bins provide convenient content storage, organization, and transport for heavy, bulky items
- Features a wide front opening for easy access. 1 rear and 2 side grip handles. Stabilizing ribs permit bins to stack
- The large-size bins have large label slot, small-size bins have front label area that accommodates adhesive labels
- Add color suffix: Gray (GY), Blue (BL), Red (RD), Yellow (YL), Beige (BG), Black (BK), Green (GN), Sold in carton quantities.

W" x D" x H"	Ctn. Qty.	Bin Model	Clear Bin Model
19 ⁷ / ₈ x 15 ³ / ₄ x 12 ⁷ / ₁₆	3	752397	B472287
10 ⁷ / ₈ x 17 ¹ / ₂ x 12 ¹ / ₂	4	652733	B472286



AKROBIN® PLASTIC STACK & HANG BIN

Strong industrial-grade polymer bins hang or stack to accommodate your storage needs. Anti-slide stops and reinforcing ribs help prevent shifting and spreading when full. Twelve 8¹/₄"W x 14³/₄"D x 7"H bins per carton.

Add color suffix when ordering bins: Blue (BL), Red (RD), Yellow (YL), Beige (BG), Black (BK), Green (GN), Sold in carton quantities.



184815BL

Model	Ctn. Qty.	W" x D" x H"
184813	6	11 x 10-7/8 x 5
239709	6	11 x 18 x 10
188014	6	16-1/2 x 10-7/8 x 5
184816	6	16-1/2 x 14-3/4 x 7
184818	3	16-1/2 x 18 x 11
188013	12	4-1/8 x 10-7/8 x 4
184810	24	4-1/8 x 5-3/8 x 3
184811	24	4-1/8 x 7-3/8 x 3
184812	12	5-1/2 x 10-7/8 x 5
188015	12	5-1/2 x 14-3/4 x 5
184817	6	8-1/4 x 18 x 9
184814	6	8-1/4 x 10-3/4 x 7

500165YL



500163BL



SUPER-CAPACITY BIN RACKS AND PANELS

- Heavy-duty 16-gauge steel construction
- Louvers provide easy hang and removal of stacking bins
- Accepts bins of different size, colors, and configurations
- Mobile racks feature 3" non-marring rubber wheel swivel casters
- Floor racks allow floor anchoring for stability
- Wall panels with pre-drilled holes allow easy wall mounting

Model	Type	Bin Qty.	Bin Color	Bin W" x D" x H"
550180YL	Double-Side Mobile Bin Rack	48	Yellow	8 ¹ / ₄ x 14 ³ / ₄ x 7
500165YL	Double-Side Mobile Bin Rack	48	Yellow	4 ¹ / ₈ x 7 ³ / ₈ x 3
		24	Yellow	5 ¹ / ₂ x 10 ⁷ / ₈ x 5
		24	Yellow	8 ¹ / ₄ x 14 ³ / ₄ x 7
500163BL	Single-Side Floor Bin Rack	16	Blue	4 ¹ / ₈ x 7 ³ / ₈ x 3
		18	Blue	5 ¹ / ₂ x 10 ⁷ / ₈ x 5
		8	Blue	8 ¹ / ₄ x 14 ³ / ₄ x 7
550200YL	Wall Bin Panel	32	Yellow	4 ¹ / ₈ x 7 ³ / ₈ x 3
239958	Wall Panel - 36" x 61"	0	---	---
239959	Wall Panel - 48" x 19"	0	---	---

550200YL



FLAMMABLE
KEEP FIRE AWAY
SAFETY STORAGE

STORAGE WITH PLENTY OF SPACE & DURHAM-BILITY. WE CAN SUPPLY THAT.®



B517768

LOCKING BIN CABINETS

- Store, organize, and secure small items including nuts, bolts, screws, nails and more
- Louver panels on cabinet back wall and doors to hang stacking bins. Includes adjustable steel shelf to customize cabinet configuration
- Doors open full 180°, includes 3-point locking system with padlockable handle
- Cabinet with leg is forkliftable
- Available in 12-, 14-, and 16-gauge steel cabinets in solid flush door or deep pocket flush door, and solid or clear door
- Different bin size, bin color and quantity or drawer configurations available

Bin W" x D" x H"	B517768 Bin Qty.	B517777 Bin Qty.	B2280210 Bin Qty.
4 1/8 x 5 7/8 x 3	96	96	64
4 1/8 x 7 3/8 x 3	96	NA	64
5 1/2 x 10 7/8 x 5	36	NA	24
8 1/4 x 14 3/4 x 7	24	NA	13
16 1/2 x 14 3/4 x 7	12	NA	6
Total Bin Qty	264	96	171
Cabinet Size	72" x 24" x 84"	36" x 24" x 72"	48" x 24" x 78"
Cabinet Construction	14 Gauge	14 Gauge	14 Gauge
Cabinet Door Type	Sold Flush Door	Sold Flush Door	Deep Pocket Door



B2336875

DURHAM FLAMMABLE DRUM CABINET MANUAL CLOSE DOOR

- Sturdy all welded, double wall steel construction
- 2" wide louvers support shelves, adjustable on 4" centers
- Units come fully assembled and ready for use
- Electrical ground on bottom right hand side to aid in the elimination of an electrostatic discharge
- Improved security with recessed lockable paddle latch with padlock hasp and 3 point locking system
- Bunged air vents on each side of the cabinet allows for ventilation
- Safety Yellow, powder coat finish
- In compliance with FM Approved, NFPA 30 standards when used properly

Bin W" x D" x H"	B2336875	B2336874	B2336876
Cabinet Size	34" x 34" x 65"	34" x 34" x 66 3/8"	43" x 12" x 65"
Capacity	55 Gallon	55 Gallon	30 Gallon
Cabinet Door Type	Manual Close	Self Close	Manual Close



DIVIDABLE GRID CONTAINERS

- Convenient, space-saving, organized storage for multi-sized contents
- Most efficient method of compartmentalizing and protecting small to medium parts
- Molded-in stacking ridge ensures containers will stack securely with or without covers
- Large, smooth surface area on all four sides for content identification
- Molded-in slots accept optional length and width dividers
- Conductive Grid Containers* are injection-molded with a carbon-filled copolymer polypropylene, which protects sensitive electronic components from typical electromagnetic interference (EMI). Electrostatic Decay Rate is tested to meet Mil Spec Mil-B-81075B at less than 0.1 seconds. Surface resistivity is less than 105 Ohms/Sq. when tested per ASTM-D257

Model	Color	Outside L" x W" x H"	Carton Qty.
334106	GY, BL, RD	22½ x 17½ x 6	3
334102	GY, BL, RD	16½ x 10¾ x 3½	12
B366204	Gray	16½ x 10¾ x 2½	12
B649489*	Black	22½ x 17½ x 8	4
334209*	Black	22½ x 17½ x 6	3



TOTE

NESTING UTILITY TOTE & LID

- Lightweight, tough Corrugated Plastic tote is steel band reinforced at top for added strength and rigidity.
- Easy-to-clean, resistant to dirt, moisture and grease.
- Convenient hand-holes for carrying ease.
- Nests for space-saving storage. Snug-fitting lid protects contents against dust and dirt. 18½"L x 13¼"W x 12"H. Meets U.S. Postal Service requirements.
- Add Color Suffix when ordering Blue (BL), Red (RD) or Yellow (YL).
- Mail Tray features folded, double sidewall construction.
- Nest together to save space.
- White color only. 24½"L x 12"W x 4½"H.
- Sold in carton quantities of 10.
- Available in white, Blue (BL), yellow (YL) and Red (RD)

Description	WHITE Model	COLORS Model
Tote	753500	257915
Lid	753501	257916
Tote & Lid	257816	257920
Mail Tray	238431	---



ATTACHED-LID DISTRIBUTION CONTAINERS

- Safely and securely ship and distribute materials with these durable, affordable shipping containers. Interlocking lids are permanently attached using steel hinges.
- Raised lip edges allow secure stacking.
- Molded from high density FDA approved polyethylene.
- Containers allow nesting when not in use with lids open for compact storage and to help reduce return shipping costs.
- Molded grip handles have an integral hasp to accept cable ties for security.
- Sold in carton quantities.
- Specify Color Suffix: Gray (GY), Blue (BL), or Red (RD).
- 443167 translucent container includes metal rails for hanging folders.

Model	Top Outside L" x W" x H"	Cap. Alone	Lbs. Stacked	Stack Qty.
442218	19 ⁵ / ₈ x 11 ⁷ / ₈ x 7	35	175	5
270281	18 x 13 x 15	35	175	5
257808	21 ⁷ / ₈ x 15 ¹ / ₄ x 9 ¹¹ / ₁₆	45	225	5
257809	21 ⁷ / ₈ x 15 ¹ / ₄ x 12 ⁷ / ₈	50	250	5
257810	22 ³ / ₈ x 13 x 13	45	225	5
257811	21 ⁷ / ₈ x 15 ¹ / ₄ x 17 ¹ / ₄	45	225	5
257812	24 ¹ / ₂ x 14 ⁷ / ₈ x 13 ³ / ₄	45	225	5
257813	23 ³ / ₄ x 19 ¹ / ₄ x 12 ¹ / ₂	50	250	5
257814	27 ³ / ₁₆ x 16 ⁵ / ₈ x 12 ¹ / ₂	50	250	5
238148	28 ¹ / ₈ x 20 ³ / ₄ x 15 ⁵ / ₈	60	300	5
334189	5 x 3 Label with clear holder	25/pkg.		



ALL-PURPOSE UTILITY TOTE BOXES

- All-purpose nesting bus and utility feature easy-to-clear walls and rounded corners
- Durable NSF-certified polyethylene totes provide lasting versatile containment against bacteria, mildew, and degradation
- Reinforced handles, bottoms, and ribs provide structural support for heavy loads
- Ideal for bus tote, airport security solutions, and parts storage
- Available in Gray (GY) or Black (BK)



Model	L" x W" x H"	Color
493681BK	20 x 15 x 5	Gray
493681GY	20 x 15 x 5	Black



ALUMINUM TOTE BOX CARTS

- Lug tote carts are made with lightweight tubular aluminum for long-lasting durability
- NSF-approved tote carts are ideal for food, small parts, or components
- Slide runners support Cross-Stack & Nest Lug Totes and allow quick, easy access
- Moves easily on 5" stem casters with TPR wheels
- Lug totes sold separately

Model	Overall Cart L" x W" x H"	Tote Cap.	Cap. Lbs.
493390	26 x 19 x 70	6	600
493388	28 x 16 x 33	2	200

BULK MOVERS WITH POLY TUBS

- Designed for transporting a variety of items in food preparation, packing, and storage applications
- Welded aluminum design, 1½" dia. easy-grip frame
- Tubs are made from sanitary, washable, and steam-cleanable polyethylene
- NSF-certified, FDA-approved



Model	L" x W" x H"	Tub Color	Type
B1918439	33 x 20¼ x 36	Off-White	6 Bushel Mover



CHROME WIRE CARTS

- Chrome wire carts with dividable grid containers offer multi-sized, mobile content storage and organization
- Features adjustable slides for convenient container access
- Slides are height-adjustable at 1" increments
- Up to 1200 lb. capacity
- Top and bottom chrome wire shelves feature truss perimeter for extra strength and reinforcement
- Move easily on four 5" polyurethane swivel casters, 2 with brakes

Model	Overall Cart L" x W" x H"	Bin Qty.	Bin Size L" x W" x H"
269028BL	24 x 21 x 69	7	22½ x 17½ x 6

KEEP IT SAFE, AND ORGANIZED WITH OUR FULL LINE OF BINS, TOTES & CONTAINERS



EASY-ACCESS CONTAINER TRUCKS

- Easy-access slant shelf container trucks are perfect for parts picking and assembly operations
- Slant shelf allows easy access and maximum visibility, and promotes first in-first out rotation of contents
- Durable steel construction with chrome-plated finish; 1,200 lb. capacity
- Top and bottom feature flat shelves for standard storage
- Shelves easily adjust without tools at 1" increments on numbered posts
- Four 5" polyurethane swivel casters, 2 with brakes

Model	L" x W" x H"
239429	36 x 18 x 63
269009	36 x 18 x 40

EXCLUSIVE BRANDS



NEST & STACK SHIPPING TOTES

- Ideal for storing, shipping, assembly, and picking
- Made with injection-molded, high-density polypropylene, withstands temperatures from -10°F to 250°F
- Stack when full, turn 180° and nest when empty
- Features a textured bottom to ensure a non-slip grip during transport and prevent slippage on conveyor belts
- Optional lid (sold separately) protects and accepts security tie closure
- Specify color suffix: Gray (GY), Blue (BL), Red (RD)

Model	Top Outside L" x W" x H"	Lbs. Alone	Lbs. Stacked	Ctn. Qty.
274311	18 x 11 x 6	45	225	6
274318	23½ x 19½ x 13	75	375	3
274319	29½ x 19½ x 15	100	500	3



RUBBERMAID® ROUGHNECK™ STORAGE TOTES

- Made from high-density polyethylene plastic for impact-and corrosion-resistance
- Includes a detached lid to protect contents
- Built-in handles allow for secure carrying
- Three size choices: Small, Medium, Jumbo

Model	Top Outside L" x W" x H"	Gal. Cap.	Ctn. Qty.
270148	43 x 21¼ x 17½	50	4
269994	23¾ x 15¾ x 12¼	14	6
493590	15½ x 10½ x 7	3	6

STAY ORGANIZED WITH TOTES THAT STORE, STACK & EVEN SHIP



CLEAR STORAGE TOTES WITH LID

- Clear storage totes made with a white or clear plastic lid for easy viewing of contents from any angle
- Provide practical, efficient storage for any light-duty application
- Choose totes with ergonomic latches or snap lid to keep items securely in place
- Choose from recessed lids or lids with an indexed surface area for stability when stacking

Model	L" x W" x H"	Ctn. Qty	Cap. Qt.
B2142303	14 x 11 x 3¼	6	5.5
B2142300	23¾ x 16¾ x 13¼	6	66
493497	29 x 17¼ x 13¼	4	95



RUBBERMAID ACTIONPACKER® LOCKABLE STORAGE BOXES

- Weather- and impact-resistant construction for reliable performance over time
- Double-walled lid fits tightly to protect contents
- Grooved surface repels water, preventing it from pooling on the lid
- A sturdy locking latch accepts padlock (sold separately) to keep the contents safe
- For added stability a bungee cord (sold separately) can also be used

Model	L" x W" x H"	Ctn. Qty	Gal. Cap.
269997	19¾ x 14¾ x 12¾	4	8

EXCLUSIVE BRANDS



652745



662113

STRAIGHT WALL CONTAINERS

- Create a complete storage and transport system or use individually
- Stackable and reinforced straight-wall design to maximize storage space
- Comfortable grip handholds on all four sides
- Choice of solid sides and base, mesh sides and solid base, or mesh sides and base

Model	L" x W" x H"	Color
652745	24 x 15 x 7½	Gray
662125	23¾ x 15¾ x 12¾	Gray
662113	23¾ x 15¾ x 12¾	Gray

EXCLUSIVE BRANDS



CROSS-STACK & NEST LUG/TOTE BOXES

- FDA-approved, ideal for transporting and storing food, recyclables, or parts
- Easy 90° positive cross-stacking for great versatility
- Nests to save space when empty
- Rugged one-piece polyethylene totes have extra-thick walls and reinforced ribs to provide greater stability and support
- Molded-in grooves for easy gripping and handling
- Fit with NSF Aluminum Lug Carts to store and transport food conveniently
- A wide range of sizes and colors available

Model	Cap. Cub. Ft.	Gal. Cap.
334180	2160	9.35

MONOFLO INTERNATIONAL



155215A

FOLDING BULK SHIPPING CONTAINERS & LIDS

These AIAG-approved recyclable bulk containers fold to save on return shipping costs (252 folded containers fit in a 53' truck). High-pressure, injection-molded plastic provides containers with resistance to impacts and rot. Four-way forklift access. Optional lid available separately.

Model	L" x W" x H"	Cap. Lbs.
155212	48"L x 45"W	Lid for 155215A and 442211A
155215A	48"L x 45"W x 27"H	1,500 lbs.
442211A	48"L x 45"W x 34"H	2,000 lbs.

EXCLUSIVE BRANDS



114007GY

FIBERGLASS STACKING BOXES

- Reinforced polyester fiberglass construction endures temperatures from -40° to 300°F
- Withstands oils, grease, degreasing, and operation cutting oils
- No sharp edges, won't damage delicate machined parts
- Stacking totes are up to 200 lb. capacity
- Stack and Nest Super Tuff Totes holds up to 300 lb. capacity
- A wide range of sizes and colors available
- Optional dolly and lid are available to protect contents and to move with ease

Model	L" x W" x H"	Style	Cub. Ft.
114007GY	25¾ x 17¾ x 3	Stack	.63
603091WH	18¾ x 11½ x 11¾	Stack	.18
422196GY	17½ x 10½ x 5	Stack & Nest	.3
422202GN	24¼ x 14¾ x 8	Stack & Nest	1.1



EXCLUSIVE BRANDS

FOLDING WIRE CONTAINERS

- Set up in seconds, fold flat to save space and shipping costs
- Made from strong, arc-welded wire mesh with heavily-reinforced corners and a channel-formed steel base
- Open mesh allows excellent visibility of contents and inventory control with minimal dust build up
- Drop gate allows access when stacked
- Notched legs interlock for positive stacking and permit forklift or pallet truck entry
- Add optional casters for mobility, or lid for security

Model	L" x W" x H"	Inside H"	Drop Gate Side"
3000 LB. CAP. - 11-gauge 2" x 2" wire mesh, Powder Coat Finish			
493394	48 x 40 x 42½	36	48
493396	40 x 32 x 34½	28	40



EXCLUSIVE BRANDS

EASY-ASSEMBLY BULK CONTAINERS

- Made from reinforced high-density blue structural polypropylene
- Hold up 600 lbs.
- Included feet allow containers to stack up to four high for 2000 lb. total capacity
- Stacking feet allow 4-way fork entry
- Ships flat; easy to assemble with included hardware

Model	Type	L" x W" x H"
603087DC	Container w/Casters	39½ x 31½ x 34
603087DP	Container w/Lid & Casters	39¼ x 31½ x 34

EXCLUSIVE BRANDS

FOLDING BULK CONTAINERS

- Made from polyethylene to resist rust, odors, and moisture
- Structurally reinforced at all stress points for added strength and stability
- Smooth interior surface clears easily
- 3:1 return ratio reduces costs on return freight and storage
- 4-way forklift; 2 hinged drop-down doors for easy access to contents
- Spring-latches automatically lock sidewalls for easy set-up and quick folding



Model	L" x W" x H"	Cap. Lbs.
155208	32 x 30 x 34	1800
270284	32 x 30 x 25	1800



800116B



B2050724

ALL-WELDED STACKABLE STEEL CONTAINERS

- Quality engineered for the toughest industrial uses
- Heavy-duty stacking legs allow four-way accessibility for easy fork or pallet truck handling
- Container with drop gate allows easy access to contents
- Available in rigid steel and mesh sides, different sizes and colors

Model	L" x W" x H"	Style
800116B	48 x 42 x 24	No Drop Gate
800102M	35 x 30 x 24	One Drop Gate
B2050724	38 x 38 x 16	Mesh Sides, Gray



155202GY



652755BL



652948

PLASTIC BULK CONTAINERS

- FDA- and USDA-approved; ideal for agricultural, pharmaceutical, industrial, and food service use
- Extremely rugged, withstands impacts, chipping, and corrosion. Reusable
- One-piece molded plastic that is easy to clean
- Containers without casters are stackable
- Available in different designs, sizes, and capacities

Model	L" x W" x H"	Cap. Lbs.
155202GY	48 x 44 x 29	700
652755BL	48 x 40 x 31	1500
442922	48 x 42 x 29	1000
652948	43½ x 43½ x 43½	1200

LIGHTS

Attach to optional uprights to provide direct overhead lighting.

PANELS & MOUNTING KITS

Enhance versatility and convenience with pegboards and louvers.

MOUNTING ARMS & TRAYS

Help maintain both temperature and ergonomic comfort.

BINS

Provide quick and easy reach to essential parts.

Choose between several styles and configurations.

POWER STRIPS

Offer multiple options for plugging in and powering up.

HOW-TO GUIDES WITH INDUSTRIAL- STRENGTH. KNOW-HOW. WE CAN SUPPLY THAT.®

When you have a bench that works against you, we have a workbench guide for you. When you have a stockroom with more stock than room, we have storage & shelving guides for you. When you have a warehouse that feels more like an icehouse, we have a heater guide for you. Find our How-To Guides at our online Knowledge Center and discover the perfect solution that your business needs.

MATERIAL HANDLING

40-51

EXCLUSIVE BRANDS



988854

BATTERY-POWERED MOBILE SCISSOR LIFT TABLE

- Reduce undesirable lifting and workplace injuries
- Ergonomic handle provides easy steering and control
- 40+ elevations per charge
- Durable steel construction ensures long-lasting use

Model	Table L" x W"	Height Range"	Lift Time	Caster Dia."	Lbs.
988854	40 x 20½	19½-63¾	20 Seconds	6	1100
988159	40 x 20½	20½-72¾	15 S +/-5S	7¾	2000

TILTING WORK TABLES

- Places material at an ergonomically-correct level, reducing fatigue and risk of injury
- Tilt angle and platform height are easily adjusted
- Powder coated steel construction with lip edge on platform to retain load
- Four 4" diameter polyurethane swivel casters allow transportation with a full load



Model	Platform L" x W"	Height Range**	Platform Cap. Tilt°	Lbs.
241728	22 x 21	28-38	45	150
241729	24 x 24	31½-42	30	300

*Platform in level position

MOBILE SCISSOR LIFTS & TILT TABLES

- Compact and maneuverable—perfect portable workstations
- An ergonomic answer to lifting, positioning, and transporting heavy loads
- Foot-operated hydraulic pump raises platform to any height within lift range
- Smooth rate of lowering using finger release, regardless of the load weight
- Durable chip-resistant powder coat finish



Model	Cap. Lbs.	Table L" x W"	Height Range"	Strokes to Max. H	Caster Dia."
SINGLE SCISSOR LIFTS					
168073	330	27½ x 17½	10 x 29½	20	4
168074	550	32½ x 19½	12¼ x 35½	28	5
168075	1100	39½ x 20¾	16¾ x 39	55	6
168076	1650	39½ x 20¾	16¾ x 39	65	6
DOUBLE SCISSOR LIFTS					
168077	660	39½ x 20¾	17 x 61¾	75	6
168078	1100	39½ x 20¾	17 x 61¾	85	6
LIFT & TILT TABLES					
168079	400	29½ x 19½	12¾ x 31¾	16	5
168080	600	36 x 24	14½ x 36½	25	5



168110

PORTABLE EXPANDABLE CONVEYORS

Instantly set up conveyor lines for shipping, receiving, assembly, and packaging areas. Rugged 5/16" steel axles and self-tracking skate wheels with enclosed steel ball bearings offer smooth material flow. 175 lbs. per foot capacity. 7" minimum package size. Seven zinc-plated telescopic legs adjust independently from 31¼" to 40½"H to achieve maximum gravity flow and create banked curves. All units bend around a 27" radius. Includes couplers to connect additional conveyors. Widths available from 14" to 24" with wheels per axle.



989018

POWER SCISSOR LIFT TABLE

Provides reduced worker strain at a very affordable price. Table promotes employee safety by lifting loads to a comfortable working height. Hand-held pushbutton pendant control. Powerful 1½ HP 115V 1-phase motor and pump assembly offer years of use. Captured rollers reduce the risk of injury. Chip-resistant powder coat finish. Meets ANSI standards for lift tables.

Model	Cap. Lbs.	Platform L" x W"	Lowered H"	Raised H"	Lift Time
989018	2200	48 x 28	7¾	40	18 seconds



123007



BISHAMON® EZ LOADER® SELF-LEVELING PALLET CAROUSEL POSITIONER

The Bishamon® Ez Loader® Self-Leveling Pallet Carousel Positioner adjusts automatically, keeping the top of the load at a convenient working height via a proven Firestone Airstroke™ Actuator pneumatic support system. Totally self-contained and does not require constant air source (requires initial air pressure of 60 psi). A three-position. 49"L x 24-5/16"W base and 43" O.D. turntable. Has a lowered height of 10-1/2" and a raised height of 30-1/2". CE marked under Machinery Directive (2006/42/EC).

MOVE IT ALONG WITH OUR MATERIAL HANDLING OPTIONS

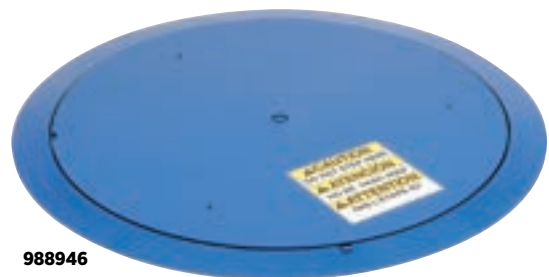

988946

PALLET TURNTABLE

Increase productivity and reduce muscle strain from stretching and reaching over and around loads. Precision anti-friction ball bearings allow for 360° pallet rotation by a single person. Low-profile 7/8" overall height allows pallet truck access for efficient load transfer without a pit. Includes lock to prevent unwanted rotation. Strong steel construction has chip-resistant finish. Unit can be moved; does not require lagging to the floor.

Model	Overall Dia.™	Usable Dia.™	Wt. Lbs.
988946	60	51	247

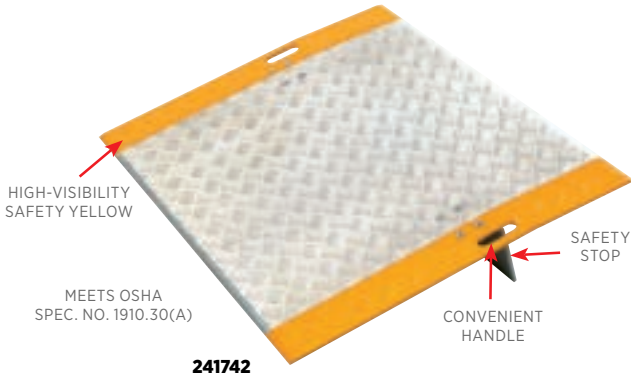

241742

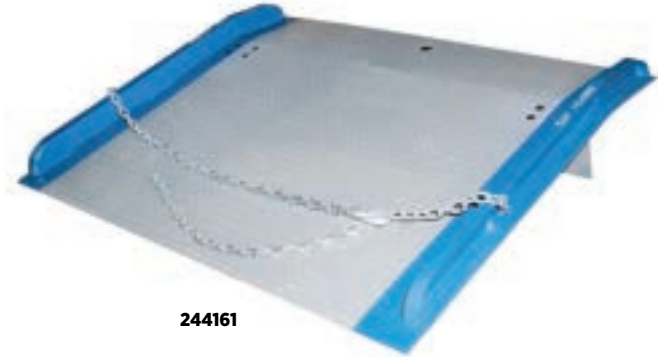

244161

HIGH-TRACTION ALUMINUM DOCK PLATE

Lightweight 3/8" aluminum is strong enough to withstand heavy traffic with diamond tread surface for traction. Integrated handholds allow it to be lifted easily. The 11" apron with beveled edges and an 11° crown provide smooth, efficient entry and exit. Includes a bolted safety stop to keep plate in position. Width should be 12" wider than load. Not for use with rider trucks.

Model	W"x L"	H"*	Cap. Lbs.	Wt. Lbs.
241742	36 x 24	1	3350	35

*Height is the difference above or below dock.

DOCK BOARD WITH STEEL CURBS

Full-length handgrip for safe & easy handling with a slip-resistant diamond tread surface. Beveled entry and exit edges, 11" apron, and 11° crown angle offer smooth transition between truck and dock. Safety stop underneath helps secure plate in position. Width should be 12" wider than load. Not for use with rider trucks.

Model	W"x L"	Cap. Lbs.	Wt. Lbs.
244161	60 x 48	10,000	333

**TAKE A LOAD OFF,
AND PUT IT ON OUR DOCKS**

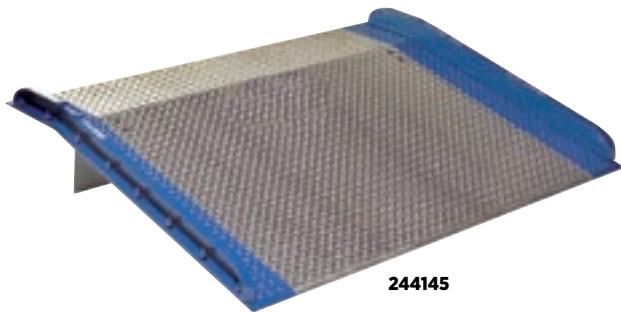

244145

DOCK BOARD

Speed up loading operations, help prevent accidents, and reduce labor costs. Resilient aluminum construction with anti-skid diamond tread surface and high-visibility beveled curbs for maximum safety. Bolted-on steel curbs offer excellent impact-resistance to help prevent run-off. Safety stop on underside, so board will not move under load. An 11° angle supplied unless another angle of operation is specified. 11" entry lip with rounded nose protects tires. Meets OSHA requirements 1910.30(A).

Model	W"x L"	Cap. Lbs.	Wt. Lbs.
244145	60 x 36	10,000	127

**BLUFF® EZ-PULL
MECHANICAL EDGE-OF-
DOCK LEVELER**

Attaches easily to steel nosing of existing dock, saving valuable dock loading space. Easy positioning by lifting and pulling the self-storing handle. Counterbalanced extension spring lift to ensure one person, one hand operation. High-strength 3/8" steel safety plate and heavy-duty hinges. Automatically releases and returns to stored position when truck exits.



986635

Model	Lip W"x D"	Overall W"
986635	72 x 27¾	94

EXCLUSIVE BRANDS



298721

STABILIZING JACKS

Choose from our wide selection of durable steel trailer stabilizers with a range of capacities, designs, and features. From light-duty economy models appropriate for small trailers to the strongest of heavy-duty jacks, you'll find the right jack stand for your needs.

Model	Static Cap. Lbs.	Lifting Cap. Lbs.	Height Range"	Base	Top
298721	100,000	---	38¼-52¼	18" x 18"	Beam
500001	50,000	5,000	44-51	14" Dia.	5 x 5" Plate
132050	100,000	40,000	39½-51	14" Dia.	7¾" Cap
500106	100,000	50,000	39½-51	16" triangular	24"L x 6"W Beam

EXCLUSIVE BRANDS



985433

HAND CRANK TRAILER STABILIZING JACKS

These stabilizer jacks feature hand-operated cranks for easy positioning. The folding crank handle stores out of the way when not in use. High-strength steel construction with a safety yellow powder-coat finish. Helps meet OSHA 1910.178(k) (3) safety requirements to prevent dangerous trailer tip. Roll easily into position. 100,00 lbs capacity.

Model	Height Range"	Caster Dia."	Wheel Type
985433	41-55	16	Semi-Pneumatic
985432	41-55	16	Pneumatic

EXCLUSIVE BRANDS

WHEEL CHOCKS

Chock trailers, construction equipment, buses, jets, and other heavy vehicles. Protect against runaway vehicle accidents. Built-in traction grippers create maximum friction between tire and parking surface.

Model	Material	L" x W" x H"
241741	Rubber	10½ x 4½ x 7
129100	Rubber	10 x 8 x 6
117100	Urethane	11 x 8 x 8
241965	Steel	7½ x 7½ x 8½
955070	Laminated Rubber	8 x 8 x 8
133108	Aluminum	10¾ x 7 x 8

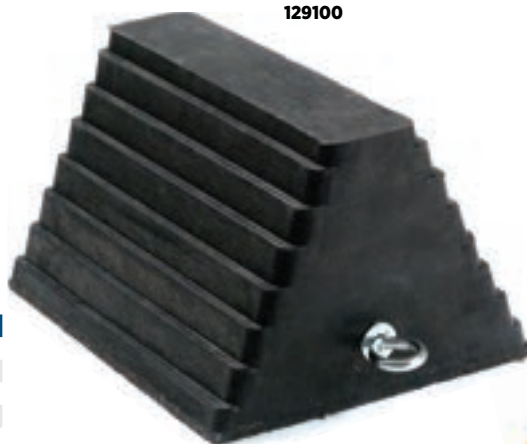

129100



241965



985369

AUTO-STAND PLUS TRAILER-STABILIZING STAND

Use this stand to help support the trailer nose during loading/unloading to prevent it from becoming front-heavy, making the process safer. A gas-operated self-leveling system raises the stand and locks it into position. 100,000-lb. static capacity helps meet OSHA 1910.178(k) (3) safety requirements.



ENERGY- SAVING STRIP DOORS

- Fastest installation of any strip door on the market
- Conserve energy and reduce noise, dust, and fumes
- Heavy-duty vinyl, clear for visibility or ribbed for durability

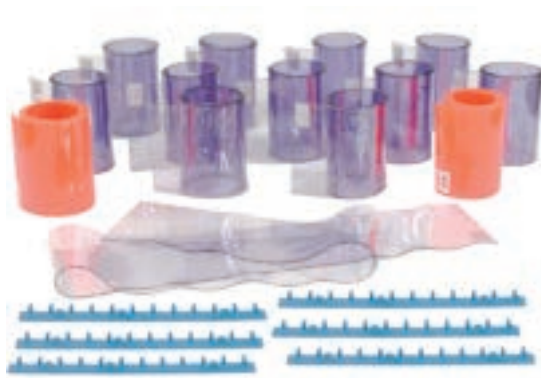

Scratch-Resistant Door Model
786104

Standard Door Model
786156

Door Opening W' x H'
7 x 7

EXCLUSIVE BRANDS



795332

FORK-MOUNTED ONE-DRUM GRIPPER

- Allows forklift operator to lift, transport, and deposit steel drums without leaving the seat
- Mounts easily on the forks
- Drum automatically releases by lowering the forks

Model	Description	Drum Gallon	Cap. Lbs.	Fork Pockets W" x D" x OC"
795332	Single Steel	55	1500	5¼ x 2 x 16



988952

MODULAR SPILL PLATFORMS AND PALLETS

- Spill containment platforms feature a low-profile design for easier loading and unloading, or taller with a higher sump capacity
- Constructed of polyethylene for impact-resistance and containment of a variety of chemicals

Model	Description	Load Capacity	L" x W" x H"
988952	2-Drum Platform	5000 lb.	51½ x 26¼ x 6½
298441	Sump with Wire Deck	4000 lb.	50½ x 50½ x 15%



472102

ACTION PUMP PISTON PUMPS

- Polypropylene - for water-based fluids, light oils, mild acids, and corrosive soaps
- Carbon steel - have chrome finish and are ideal for non-corrosive fluids
- Stainless steel - for corrosives such as MEK, acetone, and toluol

Model	Description	Dispensing Rate Oz./Stroke
472102	Stainless Steel	8
472103	Stainless Steel	22
833121	Polypropylene	2, 4, 6, 8



534100

ROTARY PUMPS

Rotary pumps are easy to operate by turning its crank handle. Liquids automatically siphon to a lower level without electricity at a volume of 8 oz per revolution. Choose Cast Iron for light oil and petroleum products or Polypropylene for water-based solutions of detergents, waxes, alkalis and salts.

Model	Type
534100	Polypropylene
833100	Cast Iron

RUGGED, STURDY, AND PORTABLE



STURDY & STRONG
SQUARE TUBULAR STEEL
CONSTRUCTION WITH
PROTECTIVE BLUE FINISH



298603



298604



ADJUSTABLE HEIGHT
WITH LOCKING PINS &
RETENTION CHAINS

STEEL GANTRY CRANES

- Rugged, sturdy, and portable
- Economical choice for heavy-duty use
- Locking swivel casters allow for positioning in many applications
- Knocks down and stores easily for transport

Model	Description	Cap. Lbs.	W' x H'
298604	Fixed	2000	10' x 7'6"-12'
320874	Fixed	6000	9'10" x 7'6"-12'
298603	Adjustable	2000	10' x 10'



ALUMINUM GANTRY CRANE

- Portable and lightweight
- Adjustable height
- Locking swivel casters allow for positioning in many applications
- Knocks down and stores or transports easily
- Use indoor or outdoor



EASILY ADJUST THE HEIGHT WITHOUT TOOLS



PNEUMATIC CASTERS FOR ROUGH SURFACES

Model	Cap. Lbs.	W" x H"
8" PHENOLIC CASTERS		
298480	2000.	7'8" x 7'8"-10'2"
298481	2000	10' x 7'8"-10'2"
298605	2000	12' x 7'8"-10'2"
B2262133	2000	9'8" x 9'6"-12'
320872	2000	12' x 7'6"-12'
B2262132	4000	12' x 9'6"-12'
241350	2000	8' x 9'6"-12'

Model	Cap. Lbs.	W" x H"
8" PHENOLIC CASTERS		
241353	2000	12' x 7'8"-10'2"
241354	2000	12' x 9'6"-12'
241355	4000	8' x 7'8"-10'2"
241356	4000	8' x 9'6"-12'
241357	4000	10' x 7'8"-10'2"
241358	4000	10' x 9'6"-12'
241359	4000	12' x 7'8"-10'2"

Model	Cap. Lbs.	W" x H"
12" PNEUMATIC CASTERS		
241361	1500	8' x 7'8"-10'2"
241362	1500	8' x 9'6"-12'
241363	1500	10' x 7'8"-10'2"
241364	1500	10' x 9'6"-12'
241365	1500	12' x 7'8"-10'2"
241366	1500	12' x 9'6"-12'



585482



585495



906251



585499



585505



585508



906245



906243

HOW TO SELECT THE PROPER WHEELS AND CASTERS

1 Select wheel type

HARD RUBBER - Highly resistant to water, oil, and animal fats. Heavy load-carrying capability and floor protection.

STEEL - Carbon steel casting. Unbreakable under in normal service.

SEMI-PNEUMATIC - For light-duty trailers, dollies, or hand trucks. "Puncture-proof", no inner tube.

FULL PNEUMATIC - For handling delicate instruments or fragile parts. Floats loads over rough floors or obstructions.

MOLD-ON RUBBER - For full floor protection where greater capacities, cushioning, and less "load starting" effort is required.

MOLDED PLASTIC/POLYOLEFIN - Resistant to many chemicals and heat. High payload capacity, protects floors, easy rolling, impact-resistant.

POLYURETHANE - Long-lasting and protects floors with a high payload capacity and excellent cushioning.

2 Determine load capacity

Per caster by adding load and truck weight and dividing result by number of supporting casters. For specific recommendations consult our engineering department.

3 Wheel diameter

The greater the wheel diameter, the easier it is to move.

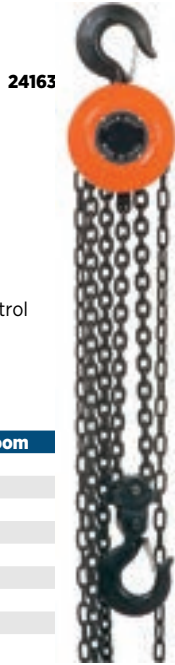

24163

CHAIN HOIST

- Drop-forged steel swivel hook with safety latch
- Hardened steel load chain for long life
- Lubrication-free load brake offers positive load control
- Tempered molybdenum steel gears
- Lightweight and ideal for low-ceiling applications

Model	Lift H'	Cap. Lbs.	Head Room
241638	10	2000	12
241639	10	4000	15
241640	10	6000	18½
241641	10	10000	23½
241642	20	2000	12
241643	20	4000	15
241644	20	6000	18½
241645	20	10000	23½

WHEN EVERY JOB IS A HEAVY LIFT, WE CAN HELP.



298514

POLYESTER WEB SLINGS

- Double wall cover for greater sling life
- Endless type; wear points can be shifted to extend sling life

Model	L'	Dia. or W"	Vertical Lbs.	Choker Lbs.	Basket Lbs.
298514	3	1½	2600	2100	5200
298490	4	1½	2600	2100	5200
298491	6	1½	2600	2100	5200
298515	3	1¼	5300	4200	10600
298492	4	1¼	5300	4200	10600
298493	6	1¼	5300	4200	10600
298494	8	1¼	5300	4200	10600
298495	10	1¼	5300	4200	10600
298496	4	1½	8400	6700	16800
298497	6	1½	8400	6700	16800

241646



"I" BEAM TROLLEY

- Extra-strong hardened wheels and axles allow the trolley to roll smoothly on beams
- Suspension plate has an opening that allows for easy hook attachments
- Spacer washers are included to adjust the trolley to fit the beam width
- Steel equalizer pin is enclosed for long-lasting strength and durability

Model	Cap. Lbs.	Beam Width"
241646	1000	2½-5½
241647	2000	2½-5½
241648	4000	3-6½
241649	6000	3-8
241650	10000	3½-8

MAGNETIC LOAD-LIFTING MAGNET

- Utilize magnetic force to elevate steel, iron, and other ferrous metals for easy handling and transport
- The easy-to-use lever rotation activates and deactivates the magnetic force for convenient and efficient operation control
- Designed to secure workloads without requiring slings, clamps, or other support devices



316088

Model	Cap. Lbs.	Magnet Size"	L" x W" x H"
316088	200	2¼ x 3¾	5½ x 2½ x 8
316089	600	3¼ x 6¾	8 x 3½ x 7
298660	800	10¾ x 4¾	10¾ x 4¾ x 8¾
316090	1200	4¾ x 9¾	11 x 4¾ x 10¾
298661	1600	11¾ x 5¾	11½ x 5½ x 10¾

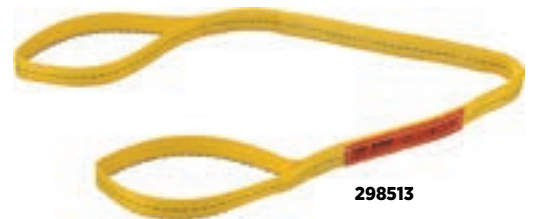

298513

POLYESTER WEB SLINGS

- Slings provide a lifting solution that will not mar or scratch the load
- Red core yarn indicates wear for easy inspection and replacement
- Eye and eye-style slings have flat ends which make them easy to remove from under loads

Model	Ply	L'	Dia. or W"	Vertical Lbs.	Choker Lbs.	Basket Lbs.
298513	2	4	1	2400	1900	4800
298517	2	6	1	3200	2500	6400
298518	2	6	2	6400	5000	12800
298507	2	8	2	6400	5000	12800
298508	2	10	2	6400	5000	12800

EXCLUSIVE BRANDS



298640

ELECTRIC CABLE HOIST

- Perfect for light-duty applications in the shop, jobsites, and in the garage
- Lightweight, portable powered cable hoist can be configured into both single- and double-line lifting
- Designed for intermittent use only and not for continuous or heavy use

Model	Cap. Lbs.	Lift H'	Lift Speed FPM	Voltage	Head Room"
298640	440	39 $\frac{3}{4}$	29.5	110	13 $\frac{1}{16}$
298641	880	39 $\frac{3}{4}$	29.5	110	14 $\frac{3}{16}$
298642	1500	39 $\frac{3}{4}$	29.5	110	15 $\frac{3}{16}$
298643	2000	39 $\frac{3}{4}$	29.5	110	18 $\frac{3}{16}$

EXCLUSIVE BRANDS



298625

AIR CHAIN HOIST

- Made with a compact housing that is built to take on heavy weights
- Pendant control is designed for easy and smooth lifting
- Equipped with chain stops and limit blocks for safer operation
- Air chain is easy to operate, pull, latch and unlatch to keep the line moving for all loads that need lifting

Model	Cap. Lbs.	Lift H'	Lift Speed FPM	Head Room"	Air inlet port size
298625	300	10	84	15 $\frac{1}{4}$	$\frac{3}{8}$ NPTF Female
298626	500	10	65	15 $\frac{1}{4}$	$\frac{3}{8}$ NPTF Female
298627	1000	10	45	15 $\frac{1}{4}$	$\frac{3}{8}$ NPTF Female



B2222075

COFFING® ELECTRIC CHAIN HOIST

- Engineered and built for the heavy-duty demands of industrial applications
- Multiple-disc motor brake, overload clutch, and chain end stop for safety

Model	Cap. Lbs.	Lift H'	Lift Speed FPM	Voltage	Head Room"
B2222075	1000	10	16	115/230	18 $\frac{1}{16}$
B2222101	2000	10	16	115/230	18 $\frac{1}{16}$
B2222100	2000	15	16	115/230	18 $\frac{1}{16}$
B2222099	2000	20	16	115/230	18 $\frac{1}{16}$
B2222098	2000	10	16	230/460	18 $\frac{1}{16}$
B2222096	4000	15	8	115/230	20 $\frac{3}{16}$
B2222095	4000	20	8	115/230	20 $\frac{3}{16}$



CM LODESTAR ELECTRIC CHAIN HOIST

- Easy access to the clutch, motor, electrical control panel and brake assembly
- Heavy-duty DC brake is designed for a long service life
- Lifetime grease-lubricated gear box and precision helical gearing ensures efficient operation
- Heavy-duty rated motors

Model	Cap. Lbs.	Lift H'	Lift Speed FPM	Voltage	Head Room"
B1299512	1000	20	16	115	16 $\frac{1}{4}$
B1299514	2000	20	16	115	18 $\frac{1}{16}$
B1299515	2000	20	16	230/460	18 $\frac{1}{16}$



HARRINGTON ELECTRIC CHAIN HOIST WITH MOTOR TROLLEY

B1797363

- Low-headroom, full-featured hoists and trolleys provide reliable performance in routine situations and severe environments
- "The Guardian": Smart Brake Technology, a current-driven electromagnetic brake that does not release unless the motor is energized
- Extremely durable and reliable pull-rotor brake, drop stops and rubber bumpers, and side guide rollers for smoother trolley motion and reduced beam wear

Model	Cap. Lbs.	Lift H'	Lift Speed FPM	Voltage	Head Room"	I beam Flange Range"	Traverse FPM
B1797363	1000	10	15	208	15 $\frac{1}{8}$	2 $\frac{1}{2}$ to 5	40
B1797428	2000	10	14	208	17 $\frac{1}{8}$	2 $\frac{1}{2}$ to 5	40
B440602	4000	20	7	460	27 $\frac{3}{16}$	3 $\frac{1}{4}$ to 6	40
B1797275	6000	20	17	230	32 $\frac{1}{8}$	3 $\frac{1}{4}$ to 6	40

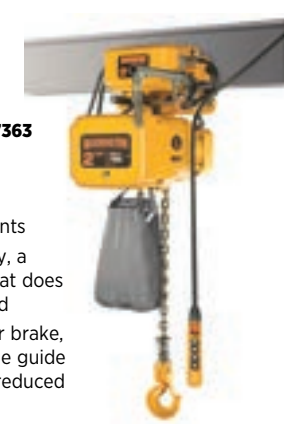



641272

HEAVY-DUTY PLASTIC STEP STANDS

- Constructed of durable polyethylene with a 500-lb. capacity
- Non-slip steps and rubber feet are perfect for wet or corrosive environments
- 2- and 3-step models have tool storage compartment
- Available in five colors

Model	Steps	W" X D" X H"
641270	1	19½ x 13½ x 12
641271	2	21 x 19½ x 24½
641272	3	20 x 28½ x 33½



607326

INDUSTRIAL STEEL ROLLING LADDER

- Solid steps with perforated treads provide slip-resistance
- Spring-loaded models have casters that retract when ladder is stepped on
- Foot pedal models feature foot-activated wheel locks
- Available in multiple sizes and capacities

Model	Step Qty.	H" to Top Step	Step W"	Base W" X D"	Lock Type
607323	4	40	16	20 x 35	Spring Loaded
607324	5	50	16	20 x 42	Spring Loaded
607326	6	60	16	24 x 49	Spring Loaded
607329	7	70	16	24 x 56	Spring Loaded
607332	8	80	24	32 x 60	Foot Pedal
607334	10	100	24	32 x 73	Foot Pedal
607336	12	120	24	32 x 86	Foot Pedal

REACH NEW HEIGHTS SAFELY WITH STURDY LADDERS & LIFTS

640771



WERNER® FIBERGLASS PODIUM LADDERS

- Ideal for working at fixed heights; easier to maneuver than scaffolds or lifts
- Extra-large platform with toe guard provides added stability
- Durable fiberglass construction with full aluminum bracing
- Users can work facing any direction
- Type 1A 300 lb. rated capacity

Model	Qty. Steps	Platform H'	Overall H'
640771	3	3	6
640772	4	4	7
640773	6	6	9
640774	8	8	11
640775	10	10	13

WERNER® ALUMINUM STEP LADDERS

- Designed for extra-heavy-duty use in construction and industrial applications
- Unique "H" spreader with hand grip for easy one-handed close and carry
- Double-riveted, slip-resistant traction-tread steps
- Tray for tools, paint, and small parts
- Type 1A 300-lb. capacity



954402

Model	Qty. Steps	H' to Top Step	Base W" X D"
954400	4	4	19 x 29
954402	6	6	23 x 42
954404	8	8	26 x 54



LIFTING SOLUTIONS YOU CAN TRUST. NEED WE SAY BALLYMORE?

Ballymore

BALLYMORE® POWER STOCK PICKERS

- Eliminates the need for ladders and associated injuries
- Rechargeable 12V DC battery uses standard 110V AC outlet
- 80-100 raise-and-lower cycles between charges
- Various working heights & capacities



640437

Model	Working H"	Platform Max H"	Cap. Lbs.
640437	14'	9'	650
640438	17'	11' 6"	650
640439	20'	14' 9"	650



BALLYMORE® LOCK-N-STOCK FOLDING ROLLING LADDERS

- Rated to withstand 350 lbs. each
- Simply fold and roll where you need it
- Folds to only 10"D for compact storage
- Locks in folded or open position for operator safety



253807

Model	Top Steps	Base Step H"	Overall W" X D"	Height"
253806	2	20	24 x 17	41
253807	3	30	24 x 23	52
253808	4	40	24 x 30	65



B3135918

BALLYMORE® HYBRID ROLLING SAFETY LADDERS

- Made of both Steel and Aluminum
- All Directional, Steel raised base
- Lift Assist Lockstep, patent pending gas spring casters
- Aluminum Stair section makes it Light Weight for easy maneuverability

Model	Top Steps	Height"
B3135918	6	96
B3135920	7	106
B3135922	8	116
B3135924	10	136
B3135925	11	146
B3135926	12	156

YOU DESERVE THE BEST, SO WE ONLY WORK WITH THE BEST



We take pride in our relationships with your favorite and most trusted national brands. Regardless of your business or your needs, the brands you know and trust are just a click away.

CARTS & TRUCKS

53-68

EXCLUSIVE BRANDS

PALLET TRUCKS

Durable and economical, these manual trucks offer the best value for your material handling needs. Features include tapered reinforced-steel forks, a spring-loaded & self-righting loop handle, 3-function hand control (raise, neutral, lower), and a hardened chrome piston with dust cover. Up to 5,500-lb. capacity.



800540

Pallet Truck
Tow Guard

334475

Model	W" x L"	Cap. Lbs.
334475	27 x 48	5500
251783	27 x 42	5500
251784	21 x 48	5500
251785	21 x 36	5500
988184	27 x 60	4400
989031	27 x 48	5500
989032	21 x 48	5500

ELECTRIC PALLET TRUCKS

Semi-electric and fully-powered pallet trucks lift and lower loads with the push of a button and maneuvers loads up ramps & inside trailers. Reinforced welded forks for years of service. High-torque drive and lift motors. Up to 4,000-lb. capacity.

Model	Brand	Type	Cap. Lbs.	Fork W" x L"	Battery Voltage	Amp/Hr.
988993	Global Industrial	Self-Propelled Walkie	3300	27 x 45	12	65
989069	Global Industrial	Self-Propelled Walkie	4000	27 x 45	12	85
989068	Global Industrial	Semi-Electric	3300	27 x 45	12	30
242071	Big Joe	Self-Propelled Walkie	3000	27 x 45	12	65

EXCLUSIVE BRANDS



988955

FULLY-POWERED STACKER

This battery-powered stacker is a good choice for general material handling, stacking, and work positioning. Its tight 55" turning radius allows it to maneuver well in tight aisles. Ergonomic handle controls speed and lift with left or right hand. 2,650-lb. capacity.

- Straddle legs are 38" to 50" I.D.; 47.5" to 59.5" O.D.
- Forks inside adjustable straddle legs adjustable from 9½" I.D. to 31" O.D."
- Overall 62"L x 59½"W x 85"H
- Lowered height 2½", raised height 65"

EXCLUSIVE BRANDS

OFFICE & LAB LIFT TRUCK

This light-duty lift truck is perfect for heavy office files, computers, and equipment. Place loads on the acrylic platform and raise with a hand winch or battery-powered motor. Easily fits through doorways and narrow aisles. 220-lb. capacity. Lowered height 5½" Raised height 67".

BATTERY
POWERED
988927



988993



242071



EXCLUSIVE BRANDS



988934

MANUAL-LIFT STACKERS

Perfect for lifting and positioning cumbersome office files, computer equipment and mailroom supplies, this stacker is easy to maneuver in confined spaces. Features include a foot-operated hydraulic pump and adjustable forks for added flexibility. Durable steel construction.

Model	Cap. Lbs.	Lowered H"	Raised H"
988934	880	3½	47
988935	880	3½	59
Model	Description		
988936	Optional 26" x 22" Slip-On Platform		

EXCLUSIVE BRANDS

1000 lb.
Capacity



B287947

PANEL TRUCKS

These panel trucks have a 12-gauge steel frame for long lasting durability and dependability. Swivel casters with 5" dia. non-marking polyurethane wheels provide smooth transport. Three removable uprights extend 27" above the deck. Wood ends at base protect the load. Holds up to 1,000-lbs.

Model	Deck Type	Deck H"
B287947	Wood Open Deck	7¾
B287844	Carpet Open Deck	8

2000 lb.
Capacity

"A" FRAME SHEET & PANEL TRUCKS

Double-sided sheet and panel trucks can be loaded from both sides, and still have room between the uprights for additional materials. Ideal for moving plywood, drywall, or panels. Base is 12-gauge steel with 6" dia. phenolic casters: 2 rigid, 2 swivel. 2,000-lb. capacity.



B899733

Model	L" x W"	Deck H"
B899723	36" x 24"	6"
B899733	48" x 24"	6"
B899761	60" x 30"	9"
B899762	72" x 36"	9"

EXCLUSIVE BRANDS



241444

2400 lb.
Capacity

60" L x 30" W Deck



241444C
OPTIONAL
CARPETED DECK

EXCLUSIVE BRANDS



585231

ADJUSTABLE PANEL TRUCKS

Adjustable panel trucks transport cargo of multiple sizes. Uprights in three different sizes are sold separately. Truck platforms are constructed with a strong angle iron frame and rounded safety edges with scratch-resistant blue enamel finish. Capacities: 1,200 to 2,400-lbs.

	6" Dia. x 2"W Mold-On Rubber Wheels 2000 Cap. Lbs.	8" Dia. x 2"W Mold-On Rubber Wheels 2400 Cap. Lbs.	8" Dia. x 2½"W Full Pneumatic Wheels 1200 Cap. Lbs.
L" x W"	Model	Model	Model
48 x 24	241543	585228	585229
60 x 30	241544	585231	585232
UPRIGHT FRAMES (Sold in Pairs)			
H" x L"	Model	H" x L"	Model
12 x 48	585233	12 x 60	585236
26 x 48	585234	26 x 60	585237
38 x 48	585235	38 x 60	585238

PANEL AND LUMBER TRUCKS

Transport plywood, drywall, lumber, pipe, and other long, bulky products with ease. Removable steel pipe uprights and strong 14-gauge channel-reinforced steel deck with welded upright sockets for maximum durability. Scratch-resistant enamel finish. Specify carpeted deck suffix (C) to model.

6" Dia. x 2"W Mold-On Rubber Wheels 2000 Cap. Lbs.	8" Dia. x 2"W Mold-On Rubber Wheels 2400 Cap. Lbs.	8" Dia. x 2½"W Full Pneumatic Wheels 1200 Cap. Lbs.
Model	Model	Model
241443	241444	241445

DOCUMENT
HOLDER
489070Y



STEEL-DECK TRUCKS

All-welded 14-gauge steel decks with internal reinforced channel for extra strength. Non-marring integral corner bumpers protect walls. Includes four casters, 2 swivel and 2 fixed, and a removable pipe handle. Durable baked enamel finish. Up to 2,400-lb. capacity.



EXCLUSIVE CHANNEL-REINFORCED DECK



OPTIONAL ERGO HANDLE

952112P

PROTECTIVE BUMPERS

SHOCK-ABSORBING PNEUMATIC WHEELS

Deck	5" Dia. Polyurethane Wheels 1000 Cap. Lbs.	8" Dia. Full Pneumatic Wheels 1200 Cap. Lbs.	5" Dia. Rubber Tired Wheels 1400 Cap. Lbs.	6" Dia. Rubber Tired Wheels 2000 Cap. Lbs.	8" Dia. Rubber Tired Wheels 2400 Cap. Lbs.
L" x W"	Model	Model	Model	Model	Model
36 x 24	952105	952110P	952110	952121	952130
48 x 24	952106	952112P	952112	952123	952132
48 x 30	952107	952113P	952113	952122	952139
60 x 30	952108	952116P	952116	952127	952136
72 x 36	952109	952118P	952118	952129	952138

ALUMINUM DECK TRUCKS

Lightweight and strong aluminum decks make these the perfect choice for moving bulk product. All-welded 10-gauge deck with a 7-gauge aluminum channel frame, the deck is slip-resistant to help keep items onboard. Corner bumpers protect walls. Up to 2,400-lb. capacity.



2400 lb. Capacity

241552

ADDITIONAL REMOVABLE ALUMINUM HANDLE	
Deck W"	Model
24	241554
30	241555
42	241595



FREE PROTECTIVE BUMPERS



NON-SLIP DIAMOND TREAD

Deck	5" Dia. Polyurethane Wheels 1000 Cap. Lbs.	5" Dia. Rubber Tired Wheels 1400 Cap. Lbs.	6" Dia. Rubber Tired Wheels 2000 Cap. Lbs.	8" Dia. Rubber Tired Wheels 2400 Cap. Lbs.	8" Dia. Full Pneumatic Wheels 1200 Cap. Lbs.
L" x W"	Model	Model	Model	Model	Model
48 x 24	241549	241550	241551	241552	241553
48 x 30	232596	232600	232610	232620	232630
60 x 30	232597	232602	232612	232622	232631
56 x 42	241590	241591	241592	241593	241594

HARDWOOD PLATFORM TRUCKS

Superior performance at affordable prices. Flush 7/8" thick, kiln-dried and sealed wood deck is reinforced with cross battens for long life. Removable cross-braced tubular steel handle. Rolls smoothly on 2 swivel, 2 rigid casters.

952500P
HARDWOOD DECK TRUCK



OPTIONAL DOCUMENT HOLDER
489070S

Deck	5" Dia. x 1 1/2" W Polyurethane Wheels 1000 Cap. Lbs.	5" Dia. x 1 1/2" W Rubber Tired Wheels 1400 Cap. Lbs.	6" Dia. x 2" W Rubber Tired Wheels 2000 Cap. Lbs.	8" Dia. x 2" W Rubber Tired Wheels 2400 Cap. Lbs.	8" Dia. x 2 1/2" W Full Pneumatic Wheels 1200 Cap. Lbs.
L" x W"	Model	Model	Model	Model	Model
48 x 24	952509	952500	952516	952501	952500P
54 x 27	952511	952503	952517	952502	952502P
60 x 30	952513	952505	952518	952504	952504P
72 x 36	241697	952507	952519	952506	952506P

168259
ANTI-SLIP GRIP HANDLE
CURVED HANDLE (A)
10" SHOCK ABSORBING PNEUMATIC WHEEL

800541
LOOP HANDLE (B)
10" MOLD-ON WHEEL

168263
DOUBLE HANDLE (C)
8" MOLD-ON RUBBER WHEEL
SHOWN WITH OPTIONAL STAIR-CLIMBERS AND FOLDING NOSE

168264
ADDITIONAL FRAME RAIL
PIN HANDLE (D)

FOLDING NOSE EXTENSION
30"L x 12"W extension helps carry bulky loads. 300-lb. capacity. Fits all styles.
Model 168254

STAIRCLIMBERS
Cast aluminum with wear strips. Fits all styles.
168256

REPLACEMENT NOSEPLATE
Model 168255

ALUMINUM HAND TRUCKS

High-strength aluminum construction offers a lightweight alternative to heavier steel hand trucks. Exclusive design offers 33% greater frame reinforcement. Large beveled noseplate accepts bulky loads and has integral wheel guards to protect cargo. 500 lb. capacity.

Style	Model	Wheel Dia."	Type	Overall H" x W"	Noseplate W"xD"	Wt. Lbs.	Style	Model	Wheel Dia."	Type	Overall H" x W"	Noseplate W"xD"	Wt. Lbs.
A	168257	8 x 1.75	Mold-On	51 x 18	18 x 7.5	26	C	168261	10 x 2.5	Semi-Pneu.	49 x 19	18 x 7.5	38
A	168258	10 x 2.5	Semi-Pneu.	51 x 19	18 x 7.5	38	C	168262	10 x 3.5	Pneumatic	49 x 21	18 x 7.5	28
A	168259	10 x 3.5	Pneumatic	51 x 21	18 x 7.5	28	C	168263	8 x 1.75	Mold-On	51 x 18	18 x 7.5	26
B	168266	8 x 1.75	Mold-On	51 x 18	18 x 7.5	27	D	800541	10 x 2.5	Semi-Pneu.	51 x 19	18 x 7.5	38
B	168267	10 x 2.5	Semi-Pneu.	51 x 19	18 x 7.5	39	D	168265	10 x 3.5	Pneumatic	51 x 21	18 x 7.5	28
B	168268	10 x 3.5	Pneumatic	51 x 21	18 x 7.5	29	D	168268	10 x 3.5	Pneumatic	51 x 21	18 x 7.5	29



LARGE 10" X 3 1/2" FULL PNEUMATIC WHEELS

INDUSTRIAL-STRENGTH STEEL HAND TRUCKS

High-quality steel-tube trucks are perfect for day-to-day use. Double welding at critical stress points withstand rugged use. Choose from loop handle or curved handle for easiest load control. Wear-guard strips help prevent load damage. 600-lb. capacity.

Style	Model	Overall H" x W"	Wt. Lbs.
E	585283	52 x 22	30
F	241582	52 x 22	30
G	241439	49 x 22	32

F

E

G STAIR CLIMBERS

FOLDING NOSE EXTENSION

SHOP OUR CARTS & TRUCKS

ALUMINUM 2-IN-1 HAND TRUCKS

The spring-loaded, auto-release bars instantly convert these quality hand trucks into platform trucks. Features a high-strength lightweight aluminum frame. Beveled aluminum noseplates make loading easier and wheel guards protect loads. Full pneumatic wheels and phenolic swivel casters roll smoothly on any surface. Optional snap-on deck sold separately.

Style	JUNIOR	SENIOR
Hand Truck H"	52	62
Platform Truck H"	40	45
Platform Bed L"	43	56
Platform Bed W"	12	12
Hand Truck Cap. Lbs.	500	500
Platform Truck Cap. Lbs.	800	800
Weight Lbs.	42	48
Model	241664	241666
SNAP-ON DECKS	Model	Model
Aluminum	241665	241667
Carpeted Aluminum	241849	241850

Replacement Parts:	
Model	Description
241848	Set of (2) 5" Dia. Swivel Casters
168255A	Noseplate
241677A	Set of (2) 10" Dia. pneumatic wheels and axle kit



241301

275 lb.
Capacity



241627

440 lb.
Capacity



FOLDING HAND CARTS

Compact, collapsible carts fit neatly into overhead luggage compartments, making them perfect for airline travel. Tubular frames are lightweight but can handle heavy loads. Simple pushbutton operation retracts wheels and folds noseplate automatically in seconds.

Model	Cap. Lbs.	Type	Overall W" x D" x H"	Folded W" x D" x H"	Noseplate W" x D"	Wheel Dia." x W"	Wt. Lbs.
251847	150	Steel	16 x 16 1/2 x 39	16 x 2 1/2 x 28	15 x 11	5 x 1	9
251848	200	Steel	20 x 19 x 39	20 x 2 1/2 x 29	19 x 11	7 x 1 1/4	10
241301	275	Aluminum	19 x 13 1/2 x 42 1/2	19 x 2 1/2 x 31	19 x 13 1/2	7 x 1 1/4	10 1/2
241627	440	Aluminum	23 x 15 x 50	23 x 3 1/2 x 40	23 x 15	8 x 1 1/2	21



800500

ALUMINUM PALLET DOLLY WITH TILT ROLLER

- Move pallet loads quickly without the use of a forklift or pallet truck.
- Heavy duty extruded aluminum channel frame construction with 3-1/2" non-marking phenolic rollers. Low profile 4-1/2" deck height
- Tilt rollers allow dolly to turn

Model	L"xW"
800500	36x36
800501	48x42
800502	48x48

SELF-PROPELLED BATTERY-POWERED PLATFORM TRUCK

- Powerful, variable-speed motor to carry heavy loads
- The truck has forward and backward drive ability and automatically stops when the trigger is released
- The batteries have a 6-hr. run time with a built-in charger
- 24"W x 36"L, 1100-lb. capacity.



984688

985750



VENDING MACHINE TRUCK

- Truck can be tilted back to clear doorways
- For moving vending machines or other tall cargo
- Front wheels lock for safety
- Two nylon web cargo belts with auto-rewind ratchet
- 78"H, 1800-lb. capacity

BATTERY-POWERED LIFT TRUCK

- Lifts and lowers loads with precision
- Steel mast with roller bearings
- Includes battery, battery charger, and battery gauge
- 1000-lb. capacity, 24"W x 24"L x 68H"



988039



987722

WORK-POSITIONING POST LIFT TABLE

- Use as an adjustable workbench or positioning table
- Foot control
- Solid steel platform and base with enamel finish
- Central lift point offers sure, stable lifting

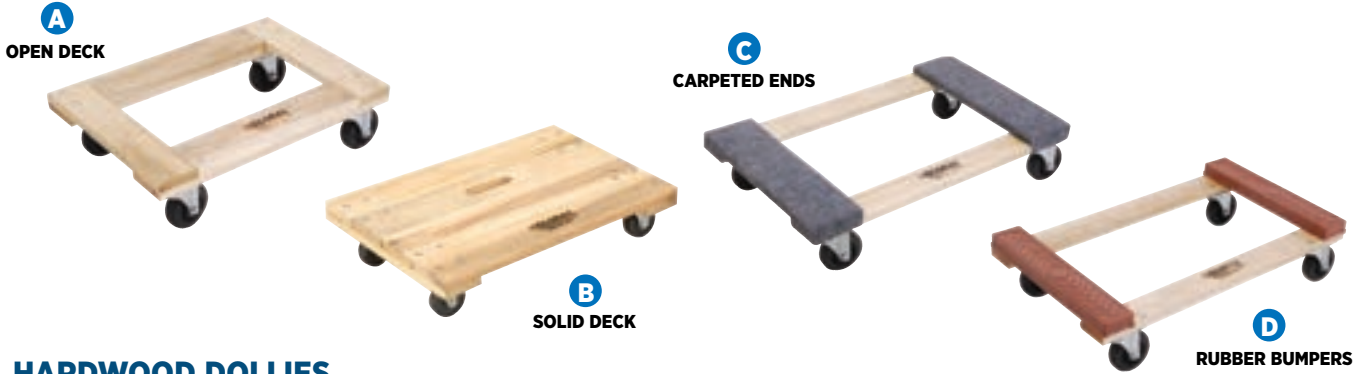

HARDWOOD DOLLIES

Made of seasoned & sealed hardwood, these dollies have a smooth varnished finish with flush-top bolted construction. Choose from solid, carpeted or rubber-ended decks. Hard rubber swivel casters. 1,200-lb. capacity.

Style	L" x W"	3" CASTER 1000 Cap. Lbs.		4" CASTER 1200 Cap. Lbs.	
		Model	Model	Model	Model
A	24 x 16	952150	952150B	952150B	952150B
A	36 x 24	952152	952152B	952152B	952152B
B	24 x 16	952154	952154B	952154B	952154B
B	36 x 24	952156	952156B	952156B	952156B
C	30 x 18	585342	585172B	585172B	585172B
C	36 x 24	585343	585344B	585344B	585344B
D	30 x 18	---	952168B	952168B	952168B

REPLACEMENT CASTERS Set of 4	
Model	Wheel Dia."
251444	3
251445	4

WE CARRY A FULL LINE OF DOLLIES



LIGHTWEIGHT PLASTIC DOLLIES

High-impact molded polyethylene dollies are lightweight and easy to clean. Will not rot, warp, or splinter. J-K models feature steel-reinforced channels for added strength and convenient steel front loop that allow the dollies to be towed with a rope or chain (not included). Solid deck units have molded-in carry handle and 3"L nylon rope for easy pulling and roll smoothly on four 3" polyurethane casters.

4" Caster-1000 Cap. Lbs.			5" Caster-1200 Cap. Lbs.	
Style	Model	Wt. Lbs.	Model	Wt. Lbs.
J	241344	14	241529	15
K	241345	16	241530	17
3" Caster-220 Cap. Lbs.				
L	251862	7		

STEEL & ALUMINUM DOLLIES

Move machinery or heavy cases and cartons. Solid aluminum deck dolly has non-corrosive, slip-resistant diamond plate surface; steel dolly has low-profile open deck with enamel finish. Four swivel 4" casters. Capacity: steel 1,600-lbs.; aluminum: 1,200-lbs.

Style	L" x W"	Cap. Lbs.	Wheel	Model
M	27 x 16	1200	Rubber	952164
M	27 x 16	1600	Steel	952165
M	36 x 24	1200	Rubber	952166
M	36 x 24	1600	Steel	952167
N	27 x 16	1200	Rubber	241523
N	27 x 16	2800	Steel	241524
N	36 x 24	1200	Rubber	241525
N	36 x 24	2800	Steel	241526



168215

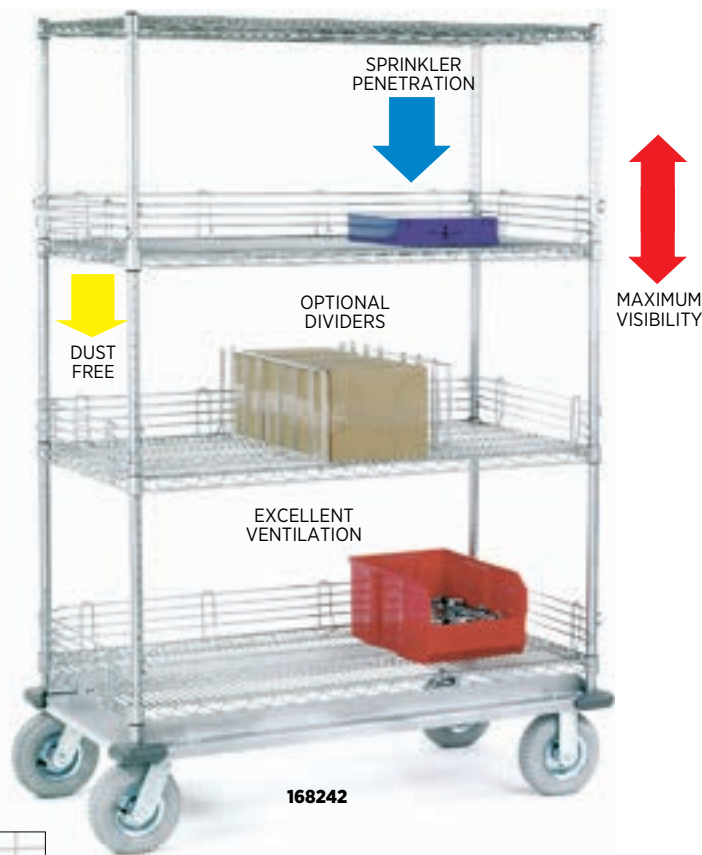

168242

ADJUSTABLE WIRE SHELF TRUCKS

Nickel-chrome-finished racks are highly durable, corrosion-resistant, and maintenance free. NSF-approved units discourage dust build-up and maximize visibility. Shelves adjust at 1" increments with an overall capacity of 1200-lbs.

Three wheel styles and many accessories available. Designed for years of service.

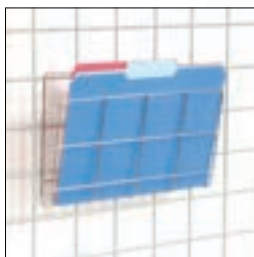

W" x D" x H"	WITHOUT BRAKES		WITH BRAKES	
	Model	Model	Model	Model
36 x 18 x 69	168214	168214B		
48 x 18 x 69	168215	168215B		
60 x 18 x 69	168216	168216B		
72 x 18 x 69	168217	168217B		
36 x 24 x 69	168218	168218B		
48 x 24 x 69	168219	168219B		
60 x 24 x 69	168220	168220B		
72 x 24 x 69	168221	168221B		
36 x 18 x 80	168222	168222B		
48 x 18 x 80	168223	168223B		
60 x 18 x 80	168224	168224B		
72 x 18 x 80	168225	168225B		
36 x 24 x 80	168226	168226B		
48 x 24 x 80	168227	168227B		
60 x 24 x 80	168228	168228B		
72 x 24 x 80	168229	168229B		

W" x D" x H"	6" Rubber (2 swivel, 2 rigid) dolly base		8" Pneumatic (2 swivel, 2 rigid) dolly base	
	Model	Model	Model	Model
36 x 18 x 63	168230	168242		
48 x 18 x 63	168231	168243		
60 x 18 x 63	168232	168244		
36 x 24 x 63	168233	168245		
48 x 24 x 63	168234	168246		
60 x 24 x 63	168235	168247		
36 x 18 x 74	168236	168248		
48 x 18 x 74	168237	168249		
60 x 18 x 74	168238	168250		
36 x 24 x 74	168239	168251		
48 x 24 x 74	168240	168252		
60 x 24 x 74	168241	168253		

NEXEL® ESD SAFE GROUND CONVERSION KIT

Weight lbs.	Model
5.8	241418A

WIRE LEDGES- Chrome. Prevents items from falling off.

L" x H"	Model
18 x 4	188580H
24 x 4	188582H
36 x 4	188584H
48 x 4	188586H
60 x 4	188588H
72 x 4	188590H

WIRE DOCUMENT HOLDER

W" x H" x D"	Model
12 ³ / ₈ x 8 ³ / ₈ x 2	489070

WIRE SHELF DIVIDERS- Attaches at any point along shelf. Chrome.

L" x H"	Model
18 x 8	188595B
24 x 8	188596B

988833



MULTI-LEVEL SHELF TRUCKS

16-gauge steel trucks are ideal for distributing components of various sizes to workstations and assembly lines. 3" deep trays keep small items contained; shelves are reversible to offer flat alternative. 800-lb. capacity. Polypropylene wheels (2 swivel, 2 rigid).

Model	Shelves	Shelf L" x W"	Shelf Gauge
988831	4	30 x 16	18
988832	4	36 x 24	18
988833	5	30 x 16	18
988834	5	36 x 24	18



NEXEL® WIRE TRAY CART & TRUCKS

Chrome-plated wire carts have open wire construction for easy access and removal of contents. Rubber swivel casters and rubber bumpers help to protect walls. Choose side- or end-load styles. Optional tray stop kit and ESD conversion kit available.

Model	Description
168315	Side-Load Cart
168317	End-Load Cart
168316	Side-Load Truck
168318	End-Load Truck
Tray Stop Kit - requires 2 per Cart or Truck.	
168319	Fits Side or End Cart
168320	Fits Side or End Truck
ESD Conversion Kit - Includes conductive Aluminum Shelf Sleeves and dissipative ground chain. For carts or Trucks.	
241288	ESD Kit
Model	Tray Style
585301	Standard
988479	ESD



489046

NEXEL® GALVANIZED OR STAINLESS STEEL SHELF TRUCKS

Available in 18-gauge epoxy-coated galvanized steel or Type 304 stainless steel shelves that adjust in 1" increments. These trucks have a corrosion-resistant finish and polyurethane wheels with donut bumpers to help protect walls. Individual shelf capacity: 400-lbs.

Galvanized Shelf Trucks are also available in 80"H

Stainless Steel Shelf Trucks are also available in 80" & 92"H

W" x D" x H"	4 SHELF TRUCK Model
GALVANIZED SHELVES	
36 x 18 x 69	489042
48 x 18 x 69	489043
60 x 18 x 69	489044
72 x 18 x 69	489045
36 x 24 x 69	489046
48 x 24 x 69	489047
60 x 24 x 69	489048
72 x 24 x 69	489049
STAINLESS STEEL SHELVES	
36 x 18 x 69	585110
36 x 24 x 69	585111
48 x 24 x 69	585112



558807A



800381

NEXEL® WIRE EXCHANGE AND TRANSPORT TRUCKS

Quickly dispense and replenish supplies throughout your facility. Choose from fully-open for easy access or 3-sided for content security. Shelves adjust at 1" increments. Choose galvanized steel or chrome wire shelves. Available in capacities up to 1000-lbs.

OPEN-SIDED			
W" x D"	800 Cap. Lbs. Model	1000 Cap. Lbs. Model	
TWO WIRE-ONE SOLID GALVANIZED SHELF TRUCK			
36 x 18	251281	251287	
48 x 18	251282	251288	
36 x 24	558812A		
48 x 24	558813A	558831A	
60 x 24	558814A	558832A	
FIVE WIRE SHELF TRUCK (Includes 3 Quick Adjust wire shelves)			
36 x 18	251283	251289	
48 x 18	251284	251290	
36 x 24	558800A	558818A	
48 x 24	558801A	558819A	
60 x 24	558802A	558820A	
FOUR WIRE-ONE SOLID GALVANIZED SHELF TRUCK (Includes 2 Quick Adjust wire shelves)			
36 x 18	251285	251291	
48 x 18	251286	251292	
36 x 24	800381	800380	
48 x 24	558807A	558825A	
60 x 24	558808A	800387	
36 x 24		558824A	
60 x 24		558826A	

3-SIDED ENCLOSED			
W" x D"	800 Cap. Lbs. Model	1000 Cap. Lbs. Model	
FIVE WIRE SHELF TRUCK (Includes 3 Quick Adjust wire shelves)			
36 x 24	800381	800380	
60 x 24	800388	800387	



912114



Folds to 6"

OPTIONAL ADDITIONAL QUICK-ADJUST SHELVES UNHOOK TO ADJUST IN SECONDS

NEXEL® SECURITY STORAGE TRUCKS

Keep valuable items such as meats, liquor, silverware, pharmaceuticals, and expensive tools secure and mobile. Lockable doors prevent items from falling out while in transit. Ideal for permanent inventory storage. Nickel-chrome electroplated finish.



800396

W" x D"	1200 Lb. Capacity Model	1600 Lb. Capacity Model	ADDITIONAL QUICK ADJUST SHELVES Model
36 x 18	800389	800404	241291
36 x 24	800391	800400	241292
48 x 18	800392	800396	241294
48 x 24	800395	800402	241295
60 x 24	800398	800403	241296
With Brakes			
36 x 18	800390		241296
36 x 24	800393		241296
48 x 18	800394		241296
48 x 24	800397		241296
60 x 24	800399		241296

SECURITY TRUCK ACCESSORIES	
Model	Description
184210	Document Holder
959101H	Keyed Padlock
241418D	ESD Kit-Includes conductive Aluminum Shelf Sleeves and dissipative Ground Chain.

FOLD-UP SECURITY TRUCK

Lockable mobile truck folds to 6"D for easy storage. Made of heavy-gauge wire mesh and 20-gauge steel tubing, it has a center shelf so you can transport large items and folds up when required. 2 swivel casters, 2 rigid. Capacity 2000-lbs. 44½"W x 27"D x 76"H overall. Shipped assembled.



988842



988841



988836

STEEL STOCK CARTS WITH DRAWERS

Durable carts have heavy-duty steel angle uprights and 3½" D trays with machine-rolled edges. Top trays are reversible for a flat tray as an alternative for bulk items. Steers easily with a formed steel tubular handle. One or two drawers, polypropylene casters.

Model	Cap. Lbs.	Trays	Drawers
988836	500	2	1
988841	500	2	1
988839	800	2	1
988842	500	2	2
988844	800	2	1
988846	800	2	2



800453



988835

988838



WELDED STEEL UTILITY CARTS

Get inventory rolling faster with better steering and support. All-welded carts have heavy-duty 12-gauge shelves and 10-gauge corner posts. Tray shelves have a retaining lip that prevents items from sliding out. Polyurethane caster kit. Max. capacity: 1200-lbs.



800460

STEEL STOCK CARTS

Heavy-duty steel uprights and machine-rolled tray edges offer superior strength. Reversible top trays offer a flat shelf alternative. Steers easily with a tubular handle and polypropylene casters. 500-lb. capacity has 20-gauge trays; 800-lb. capacity, 18-gauge trays.

Model	L" x W" x H"	Shelf Type	Shelf Qty.
800453	18 x 30	Tray	2
800454	18 x 30	Tray	3
800455	18 x 30	Flush	2
800456	18 x 30	Flush	3
800457	24 x 36	Tray	2
800458	24 x 36	Tray	3
800459	24 x 36	Flush	2
800460	24 x 36	Flush	3
800462	24 x 48	Tray	3
800461	24 x 48	Tray	2
800463	24 x 48	Flush	2
800464	24 x 48	Flush	3

Model	L" x W" x H"	Shelf Depth	Shelf Qty.	Cap. Lbs.
988835	16 x 30	3½	2	500
988837	16 x 30	3	2	800
988840	24 x 36	3½	2	500
988838	16 x 30	3	3	800
988843	24 x 36	3	2	800
988845	24 x 36	3	3	800
988847	18 x 30	2	2	800
988848	24 x 36	2	2	800
988849	18 x 30	2	3	800
988850	24 x 36	2	3	800
988851	18 x 30	2	4	800
988852	24 x 36	2	4	800



241749



242087

STANDARD PLASTIC SERVICE & UTILITY STOCK CARTS

Make your move with these rugged plastic carts. They are virtually maintenance-free, easy-to-clean, and perfect for industrial, commercial, medical, or food service applications. Includes leak-proof shelf trays, comfort grip handle, and non-marking 5" rubber wheels. Also available in 2 shelf option. 500-lb. capacity.

Model	Overall L" x W" x H"	Shelf L" x W"
241749	34 x 17½ x 33	30 x 16
498526	40 x 26 x 33	36 x 24



DELUXE PLASTIC SERVICE CARTS

These versatile carts offer convenient tool storage trays, cup-holders, and towel racks in the ergonomically-designed push handles. Tough structural foam plastic construction resists scratches & dents. Lightweight and quiet, the carts maneuver easily on 2 swivel, 2 rigid rubber casters. 500-lb. capacity.

Model	Overall L" x W" x H"	Shelf Qty.	Shelf L" x W"	Wheel Type
242080	40 x 17 x 33	2	31 x 17	5" Rubber
242082	40 x 17 x 35	2	31 x 17	6" Pneumatic
242083	40 x 17 x 33	3	31 x 17	5" Rubber
242084	40 x 17 x 35	3	31 x 17	6" Pneumatic
242081	46 x 25 x 33	2	37 x 25	5" Rubber
242085	46 x 25 x 35	2	37 x 25	6" Pneumatic
242086	46 x 25 x 33	3	37 x 25	5" Rubber
242087	46 x 25 x 35	3	37 x 25	6" Pneumatic



800329

INDUSTRIAL PLASTIC CARTS

Industrial-strength plastic stock and utility carts are virtually maintenance-free and perfect for industrial, commercial, medical, or food service applications. Choose from all-tray style or flat top model. Pneumatic or rubber casters. Comfort grip handle for easy steering. Also available in 3-shelf option. 500-lb. capacity.

Model	Overall L" x W" x H"	Shelf Style	Shelf L" x W"	Wheel Type
800299	38 x 17½ x 32½	Tray	30 x 16	Non-Marking Rubber
800297	44 x 25½ x 32½	Tray	36 x 24	Non-Marking Rubber
800328	44 x 25½ x 32½	Tray	36 x 24	Pneumatic
800300	38 x 17½ x 32½	Flat	30 x 16	Non-Marking Rubber
800298	44 x 25½ x 32½	Flat	36 x 24	Non-Marking Rubber
800329	44 x 25½ x 32½	Flat	36 x 24	Pneumatic
800334	44 x 25½ x 32½	Tray	24 x 36	Rubber
800335	44 x 25½ x 32½	Flat Top/Tray Bottom	24 x 36	Rubber
800336	38 x 17½ x 32½	Tray	30 x 16	Rubber
800337	38 x 17½ x 32½	Flat Top/Tray Bottom	30 x 16	Rubber
800344	44 x 25½ x 32½	Tray	36 x 24	Pneumatic
800345	44 x 25½ x 35½	Flat Top/Tray Bottom	36 x 24	Pneumatic



800301



800303

UTILITY CART ACCESSORIES

Make your cart work more efficiently with add-on accessories.

Model	Description
800301	2¾" Deep Square Hook (Pair), for Industrial Service Carts, Structural Foam
800302	4¾" Deep Square Hook (Pair), for Industrial Service Cart, Structural Foam
800303	Ladder hook (Pair), Structural Foam
241581*	Utility Bin and Rail Mounting Kit 21"L x 2½"W x 4"H
241678*	Waste Container with Mount Bar 14 x 10 x 19
606797GY*	Locking Steel Drawer With Divider For Plastic Or Steel Carts
241566	Power Strip With 3 Outlets For Plastic Carts, 10' Cord
498527	Replacement 8" Pneumatic Casters For Plastic Service Carts, 2 Swivel/2 Rigid

* Does not fit smaller carts 800299 & 800300

EXCLUSIVE BRANDS



184286



489062

GALVANIZED OR STAINLESS STEEL UTILITY CARTS

Durable, corrosion-resistant carts are perfect for hospitals, clean rooms, and labs. 18-gauge galvanized steel or Type 304 stainless steel shelves adjust at 1" increments on numbered posts. Polyurethane swivel casters with donut bumpers to help protect walls.

L" x W"	2 SHELF Model	3 SHELF Model
GALVANIZED SHELF		
36 x 18	489062	489065
36 x 24	489063	489066
48 x 24	489064	489067
STAINLESS STEEL SHELF		
36 x 18	184285	184288
36 x 24	184286	184289
48 x 24	184287	184290

EXCLUSIVE BRANDS



241586

STAINLESS STEEL UTILITY CART

Durable, corrosion-resistant type 304 stainless steel carts are ideal for use in clean rooms, restaurants, and other corrosive environments. 20-gauge shelves and 16-gauge uprights. Non-marring rubber casters, 2 with brakes.

Model	L" x W" x H"	Cap. Lbs.
241586	24 x 16¼ x 33	400



800292



RUBBERMAID HEAVY-DUTY ADAPTABLE UTILITY CARTS

Strong structural foam construction & 4-position adjustable handle make it easy to handle awkward loads. A flip-up shelf with 20-lb capacity eliminates the need to clear top shelf contents for work space. Slots around rim of upper shelf hold small tools and two snap-in hooks provide additional storage for extension cords or other items. Additional hooks sold separately. Rolls smoothly on 2 rigid and 2 swivel TPR rubber casters.

Model	L" x W" x H"	Cap. Lbs.
800290	46½ x 15¾ x 36	Small
800292	51½ x 25½ x 36	Medium

EXCLUSIVE BRANDS



500154

WIRE UTILITY BASKET MAIL CART

Ideal for pickup and distribution of mail, files, parts, and tools this chrome-plated cart has extra-large welded steel baskets. Bottom basket is removable for easy filling. File rails included for hanging files. Rubber and semi-pneumatic wheels. 200-lb. capacity. 44" x 22" x 35"

EXCLUSIVE BRANDS



168029

MAIL/SERVICE CARTS WITH REMOVABLE BASKETS

Keep mail and office files organized. Chrome-plated mail carrier has removable upper and lower baskets for easy loading and filling. 18-gauge and tubular steel construction has a capacity of 200-lbs. Includes rails for hanging file folders.

Standard Cart	33 x 24 x 38	200
Deluxe Cart	43 x 24 x 38	250



987556BL

-  987556GN
-  987556GY
-  987556RD



987557RD

-  987557BL
-  987557GN
-  987557GY

HOPPER-FRONT BULK TRUCKS

These trucks are designed to be reliable workhorses for commercial laundries and distribution companies. Rugged polyethylene construction is suitable for indoor or outdoor use. Cutaway opening offers easy access for loading/unloading of goods. Choose from 4 colors.

Model	Type	Capacity		Overall Dim. L" x W" x H"
		Cu. Ft.	Lbs.	
987556	Bulk Truck	43	500	46¾ x 27½ x 64
987557	Security Truck	43	500	46¾ x 27½ x 64

800315GY

800315YL

800315WH



800315RD

800315

PLASTIC BULK BOX TRUCKS

Heavy-duty trucks assist in the transport of bulky materials or trash. Seamless polyethylene molded construction will not leak; resists oils, grease, solvents, and other chemicals. Trucks nest when empty to save space. TPR rubber casters provide smooth, non-marking performance. Blue, Grey (GY), Red (RD), White (WH), and Yellow (YL).

Model	Capacity Bushel	Lbs.	Overall Dim. L" x W" x H"	Inside H"	Base Type	Wheel Dia."
800310	6	800	33¾ x 23 x 24½	21	Steel Chassis	3
800311	6	500	33¾ x 23 x 24½	21	Direct Mount Caster	3
800312	8	800	33¼ x 24¾ x 27%	23	Steel Chassis	3
800313	8	500	33¼ x 24¾ x 27%	23	Direct Mount Caster	3
800314	12	1000	38¾ x 28¼ x 33	28	Steel Chassis	4
800315	16	1000	42¾ x 30 x 35%	30½	Steel Chassis	4
800316	20	1200	50% x 34¾ x 35%	30½	Steel Chassis	4

ACCESSORIES			
Model	Description	L" x W" x H"	Fits Truck
800372	Plastic Hinged Lid	48 x 34 x 8	16 BU
800373	Plastic Hinged Lid	59 x 35 x 8	20 BU
800374	Spring Lift	38 x 24 x 2	16 BU
800375	Spring Lift	48 x 24 x 2	20 BU

241986BL

241982YL



241306

VINYL AND CANVAS BULK TRUCKS

Heavy-duty trucks assist in the transport of bulky materials or trash. Seamless polyethylene molded construction will not leak; resists oils, grease, solvents, and other chemicals. Canvas carts are water-repellent making them ideal for use as laundry carts, and feature wear-guard edges, strong kiln-dried hardwood base, & welded steel frame. Trucks nest when empty to save space. TPR rubber casters provide smooth, non-marking performance. For vinyl trucks, choose Blue (BL) or Yellow (YL).



Cap Bushel	Inside L" x W" x H"	O.A. H"	CANVAS TRUCK Model	VINYL TRUCK Model
8	34 x 22¾ x 23½	30¾	241302	241982
12	36¾ x 24¾ x 25½	32¼	241303	241983
16	40 x 28¼ x 30½	37¼	241304	241984
20	48 x 32 x 30½	37¼	241305	241985
24	53¼ x 36¾ x 30½	37¼	241306	241986



DELUXE TILT TRUCKS

Leak-proof, dent-resistant polyurethane trucks come in two sizes, three colors, and standard or heavy-duty capacities. Tilt design is perfect for hauling and dumping heavy loads. Push and pull handles provide secure handling and push handle has trash bag hooks. Blue (BL), Grey (GY), Red (RD), Black (BK).

ACCESSORIES

Model	Description	W" x H"	Color
251582	9-Pocket Utility Bag	19 x 27	Blue

Model	LID for Cu. Yd.	L" x W" x H"	Color
984612	½	46½ x 31 x 6½	Gray
241969	1	70 x 35 x 8	Gray

Model	L" x W" x H"	Cap. Cubic Yards	Color Finish	Cap. Lbs.	Model	L" x W" x H"	Cap. Cubic Yards	Color Finish	Cap. Lbs.
984613	47 x 31½ x 27%	½	Gray	850	242089	70 x 35 x 41½	1	Blue	1250
984614	46½ x 31 x 33	½	Blue	850	242096	70 x 35 x 41½	1	Gray, Black & Red	2100
800352	46½ x 31 x 33	½	Black	850	242097	70 x 35 x 41½	1	Blue	2100
984613HD	47 x 31½ x 27%	½	Gray	1400	800259	84 x 46 x 51	1½	Gray, Red, Black & Blue	2000
984614HD	46½ x 31 x 33	½	Blue	1400	800287	71 x 36 x 49	1	Gray, Red, Black & Blue	2000
800352HD	46½ x 31 x 33	½	Black	1400	800260	84 x 46 x 51	1½	Gray, Red, Black & Blue	2000
501600	70 x 35 x 41½	1	Gray, Black & Red	1000	800261	89 x 60 x 49	2½	Gray, Red, Black & Blue	2750
241847	70 x 35 x 41½	1	Blue	1000	800262	89 x 60 x 49	2½	Gray, Red, Black & Blue	2750
242088	70 x 35 x 41½	1	Gray, Black & Red	1250					

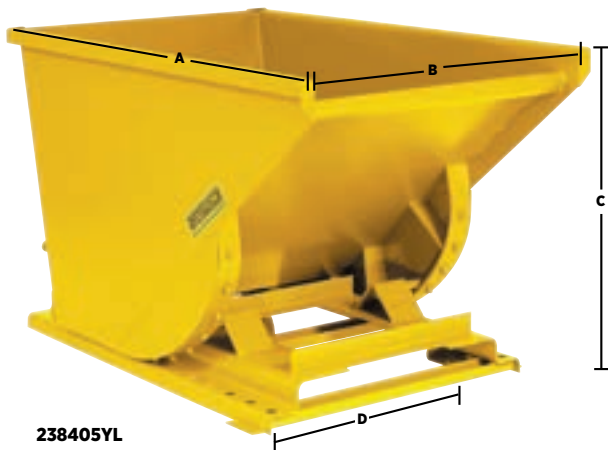

238405YL



989012

Model	Cu. Yd.	Suffix	Length A"	Width B"	Height C"	Fork Opening D"	Wt. Lbs.
MEDIUM-DUTY 1/8" (11 Gauge) Steel Plate Body with 3/16" Base							
989012	1	GY	64	40	40	3 x 28½	461
989013	1½	GY	64	58	40	3 x 28½	506
989014	2	GY	64	58	46	3 x 28½	539
238416	1	GY, YL	63½	39¾	39¾	3 x 28½	487
238417	1½	GY, YL	63½	57¾	39¾	3 x 28½	553
238418	2	GY, YL	64	57¾	46	3 x 28½	620
HEAVY-DUTY 3/16" (7 Gauge) Steel Plate Body with 3/16" Base							
238321	¼	GY	44¾	33¾	22¾	3 x 22½	300
238322	½	GY	52½	31¾	32½	3 x 20½	370
238323	¾	GY	52½	37¾	32½	3 x 20½	405
238324	¾	GY	58¾	39¾	36½	3 x 28½	511
238325	1	GY	63½	39¾	39¾	3 x 28½	562
238326	1½	GY	63½	57¾	38¾	3 x 28½	675
238327	2	GY	64	57¾	46	3 x 28½	765
HEAVY-DUTY 3/16" (7 Gauge) Steel Plate Body with ¼" HD Base							
238400	½	GY, YL	52½	31¾	32½	3 x 22½	410
238401	¾	GY, YL	52½	37¾	32½	3 x 20½	445
238403	¾	GY, YL	58¾	39¾	36½	3 x 28½	551
238405	1	GY, YL	63½	39¾	39¾	3 x 28½	602
238407	1½	GY, YL	63½	57¾	39¾	3 x 28½	715
238409	2	GY, YL	64	57¾	46	3 x 28½	805
238411	3	GY, YL	70½	57¾	55	3 x 28½	971
238413	4	GY, YL	70½	79¾	55	3 x 42½	1203
238415	5	GY, YL	70½	99¾	55	3 x 42½	1410

SELF-DUMPING STEEL HOPPERS

Hoppers are perfectly balanced to roll forward when loaded, dump completely, and automatically return to upright, locked position for reloading. Smooth edge around the top and pouring lip for added safety and strength. Choose from various sizes and capacities.

ACCESSORIES

LEGS: Opening needed for pallet jack use, clearance required; up to 6". **238510**

LIFTING LUGS: For overhead crane use. Set of 4. **238512**

CHAIN PULL LATCH: For dumping at extreme height. **238514**

THREE-WAY ENTRY: Multiple access. **238516**

Model	Wheel Type	Cap. Lbs.
238500	Semi-steel	4800
238502	Rubber	2400
238504	Plastic	4800
238506	Polyurethane	4800



VESTIL GIVES YOUR BUSINESS A LIFT.



A-LIFT-R MANUAL-WINCH LIFT TRUCKS

Ideal for areas where larger equipment can't go, they fit through standard doorways. Steel and aluminum frame, and the forks can be inverted for different lift heights. Hand-crank with a folding handle. Rolls on 8" non-marking rear wheels and 2" front swivel casters.



241655

Model	Cap. Lbs.	Legs	Counterbalanced
241656	400	Fixed	No
241655	500	Fixed	No
241654	400	Straddle	No
241653	500	Straddle	No
242029	400	Straddle	Yes
242028	500	Straddle	Yes



988132

HYDRAULIC ELEVATING CART

Material can be loaded onto this portable lift from a table or bench, lowered to a safe height for transporting, then raised at the destination for easy unloading. Moves on polyurethane casters, two swivel with brakes. 63"L x 31"H, 1000-pound payload capacity.

Model	L" x W"	Cap. Lbs.
988132	63 x 31	1000
988133	47 x 24	1500

B54011



SELF-DUMPING STEEL FORKLIFT HOPPERS

These hoppers automatically dump when the bumper release contacts the side of the dumpster, then returns to an upright and locked position automatically. A cable release lets users manually dump the hopper. Units rotate approximately 68° and are stackable.

Model	Cu. Yd.	Cap. Lbs.
B54011	1	2000
B54025	2	2000
B54028	3	6000
B2237100	4	6000
B2237099	5	6000



987971

DOCK SEAL & DOCK LEVELER DRAFT BLOCKERS

Use to block drafts between dock seals and dock levelers, each bag is made of vinyl for durability and filled with foam for compressibility. High-visibility yellow stripes for safety.

Model	L"
987970	18
987971	24
987972	36

HVAC & FANS

69-78

INDUSTRIAL PEDESTAL FANS

- Heavy-duty pedestal base and hand screw-knob for easy, tool-free height adjustments
- Provides high-powered and economical cooling and air circulation
- Comes with plug and cord pre-wired for out-of-the-box operation

Model	Fan Dia.™	HP	CFM High	Type	Oscillating
585279	24	¼	7,525	Industrial	Y
585280	30	½	8,775	Industrial	Y
292593	24	½	7,525	Deluxe	Y
652299	30	½	10,000	Deluxe	Y
652299Y	30	½	10,000	Deluxe - Safety Yellow	Y
292650	24	½	10,200	Premium	N
292651	24	½	9,400	Premium	Y
292652	30	½	9,400	Premium	N
292653	30	½	9,400	Premium	Y
292654	36	½	9,400	Premium	N
292448	24	¾	7,700	Outdoor Rated	Y
292449	30	¾	8,400	Outdoor Rated	Y
293071	24	½	7,435	Outdoor Rated - Misting	Y
293072	30	½	7,204	Outdoor Rated - Misting	Y

EXCLUSIVE BRANDS



Optional
Fan Dolly
Available
245658



INDUSTRIAL BLOWER & DRUM FANS

- Combines high-powered & economical cooling and air circulation with ease of portability
- Fan diameters range from 24" to 48"
- Most models are swivel-mounted for increased range of operation

Model	Fan Dia.™	HP	CFM High	Drive Type
292594	24	¼	7,700	Direct
607220	24	½	7,700	Direct
246607	30	½	10,440	Direct
246556	30	½	9,800	Direct
258320	36	¾	13,300	Direct
246557	36	½	11,200	Direct
246558	36	½	10,500	Belt
600554	42	1	17,600	Belt
246559	42	½	13,400	Belt
600555	48	1½	19,500	Belt
293030	24	¼	5,800	Direct - Outdoor Rated
293031	30	½	6,890	Direct - Outdoor Rated
293032	36	½	12,241	Direct - Outdoor Rated
293033	42	½	15,000	Direct - Outdoor Rated

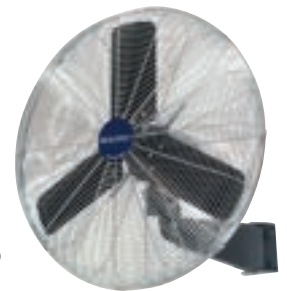

OSCILLATING INDUSTRIAL WALL FANS

- Mounts to the wall for safe, out-of-the-way operation
- Provides high-powered and economical cooling and air circulation
- Comes with plug and cord pre-wired for out-of-the-box operation

Model	Fan Dia.™	HP	CFM High	Type
607050	24	¼	7,525	Industrial
607051	30	½	8,775	Industrial
258321	24	½	8,650	Deluxe
258322	30	½	10,000	Deluxe
292648	24	½	9,400	Premium
292649	30	½	11,500	Premium
292450	24	¾	7,700	Outdoor Rated
292451	30	¾	8,400	Outdoor Rated
293073	24	½	7,435	Outdoor Rated - Misting
293074	30	½	7,204	Outdoor Rated - Misting

292791



WORKSTATION FANS

- Easily mount to walls, ceilings, workbenches, and machines
- Can be mounted to rotate 360° both horizontally or vertically
- Indoor/outdoor fan withstands the rigors of most agricultural and industrial settings

Model	Dia."	HP	CFM High	Type
294492	12	1/5	1,855	Indoor
294493	18	1/5	4,600	Indoor
294494	24	1/5	8,000	Indoor
292791	12	1/5	1,855	Outdoor
292792	18	1/5	5,650	Outdoor



293042



293104

COOLING OFF SHOULD BE A BREEZE.

CEILING FANS

- Ideal for warehouses, office spaces and other commercial areas
- Provides cooling in summer, moves stagnant air in winter
- HVLS fans provide coverage in areas up to 6,000 ft²
- HP292677 is rated for outdoor use

Model	Dia."	CFM High	Type
293103	56	8,350	Indoor
293104	60	9,150	Indoor
292677	60	8,000	Indoor / Outdoor
293047	72	11,290	Indoor
293048	96	17,018	Indoor
293049	108	19,448	Indoor
293042	144	165,600	Indoor - HVLS
293043	168	182,280	Indoor - HVLS
293044	192	199,680	Indoor - HVLS
293045	216	259,200	Indoor - HVLS
293046	240	304,000	Indoor - HVLS

AIR CURTAINS

- Air curtains help to reduce energy costs and maintain indoor air quality
- Applications include customer entrances, drive-thru windows, concession stands, and more
- NSF-certified air curtains are rated for use in the foodservice and restaurant industries where standards in food safety need to be maintained

Model	Style	Door Width"	Max. Door Height'	HP	CFM High	Amps
246608	---	36	10	1/5	815	2.85
246609	---	48	10	1/5	990	3.5
246610	---	60	10	1/5	1,280	4.8
B824551	NSF Certified	36	7	3/4	2,541	--
B824797	NSF Certified	96	7	3/4	5,081	--

246610





292871



292852

PRODUCTS THAT HELP YOU KEEP YOUR COOL



292856



292660

AIR CONDITIONERS

- Ductless AC Systems
- Industrial portable units provide effective, economical spot-cooling in commercial environments
- Many systems combine cooling and heating for total temperature control
- Outputs from 5,000 to 60,000 BTU

Model	Type	BTU Cool	BTU Heat	Cooling Sq. Ft	Voltage
292871	Mini-Split Wifi Enabled	9,000	9,500	350	115
293075	PTAC	7,000	6,000	300	208/230
293085	PTAC	15,000	10,900	700	208/230
292852	Portable	14,000	11,230	700	115
292856	Wall	12,000	---	550	115
292861	Wall	14,000	10,600	700	208/230
293082	Window	10,000	---	450	115
293067	Window	5,000	---	150	115
292660	Industrial Portable	13,200	---	355	115
292846	Industrial Portable	60,000	---	1,825	208/230



PORTACOOOL PROVIDES UNIQUE SOLUTIONS FOR COOLING PRODUCTS OF ALL SIZES

PORTACOOOL®



EVAPORATIVE COOLERS

- Provide an economical and environmentally-friendly means of keeping spaces cool
- Water and forced air are combined to reduce air temperatures by as much as 26°
- Fan diameters range from 16" to 48"
- Recommended for dry or low-humidity environments.

B2211889



B2249951



Model	Style	Fan Size"	HP	CFM High	Tank Cap. Gal.	Cooling Sq. Ft.
B2249950	Jetstream 220	---	¼	2,400	20	700
B2249951	Jetstream 230	---	½	3,600	30	900
B2211891	Jetstream 250	24	½	8,500	55	2,125
B2211890	Jetstream 260	36	¾	12,500	60	3,125
B2211889	Jetstream 270	48	1½	22,500	65	5,625

CHOOSE FROM A HUGE SELECTION OF OUR COOLEST PRODUCTS



600591

REPLACEMENT EVAPORATIVE MEDIA PADS

- Kool media manufactured by Portacool for use with Portacool evaporative coolers
- Made using virgin Kraft paper for higher levels of absorption, strength, and cooling efficiency
- High-tensile strength and high-crush strength for durability
- Stays cool for long periods of time

Model	For Use With Cooler	Units in Pack
B2249939	B2249550	3
B2249946	B2249551	3
B2211887	B2211892	3
B2211886	B2211891	4
B2211884	B2211890	5
B2211883	B2211889	6

246707



CRAWL SPACE COMMERCIAL DEHUMIDIFIER WITH PUMP

- Built to extract moisture from basements, crawl spaces, and similar areas in office buildings, warehouses, and more
- Electronic display screen and key pad interface
- On/off timer
- Purge motor for pumping and draining
- Standby mode

Model	Dehumidification Pints/Day	Refrigerant	Construction	Coverage Ft ²
246707	90	R410A	Rotomolded Polyethylene	1,000

653660



COMMERCIAL GRADE DEHUMIDIFIERS

- Low-grain refrigeration design removes water from the air
- Minimal tank maintenance
- Streamlined profile with integrated handles allow unit stacking
- Includes power cord with integrated cord wrap and drain hose
- ETL Listed

Model	Dehumidification Pints/Day	Refrigerant	Construction	Wheel Size"	W" x D" x H"
246687	110	Standard	Steel	8	17 x 21 x 33
653660	145	Low Grain	Polyethylene	12	20 x 20 x 18
246690	200	Low Grain	Polyethylene	12	22 x 22 x 32
246704	250	Low Grain	Polyethylene	12	23 x 21 x 38

KEEP IT DRY WITH OUR BEST HUMIDIFIERS

246731



OFFICE DEHUMIDIFIERS

- Energy-efficient and remote controllable
- 24-hour on/off timer
- R410A refrigerant
- 6-ft. power cord

Model	Dehumidification Pints/Day	Feature	W" x D" x H"
246730	20	Energy Star	13 x 10 x 20
246731	30	Energy Star	13 x 10 x 20
246733	40	Energy Star, Pump, WiFi	16 x 12 x 25
246735	50	Energy Star, Pump, WiFi	16 x 12 x 25

246135



ULTRASONIC COOL HUMIDIFIERS

- Releases cool mist to stabilize moisture levels
- Digital display and touchpad controls
- Smooth-rolling casters for enhanced mobility
- Lockable access door for added security
- Filter and connection hose included
- ETL/cETL listed

Model	Outlets	Output/Day	Coverage Sq. Ft.	Tank Capacity
246135	Single	80	215	38
246136	Single	150	592	38
246137	Single	300	1076	38
246138	Dual	450	1614	53
246139	Dual	600	2152	53

EXCLUSIVE BRANDS



CONFINED SPACE VENTILATOR & EXHAUST FANS

- Ventilate and cool manholes, tanks, crawl spaces, and more
- Lightweight and portable
- Rubber feet on the base help minimize noise and reduce vibrations
- Steel housings and steel wire safety guards
- Available with or without flame-retardant ducting

Model	Dia.™	CFM	Duct L'	HP
246340	8	570	---	1/8
246431	12	1,640	16	3/8
292646	16	2,850	16	1
293036	12	2,700	---	1
293035	8	1,000	25	1/8
293037	16	4,000	---	1

EXCLUSIVE BRANDS

B181977



TUBE AXIAL BELT-DRIVE DUCT FANS

- Used for duct applications in mills, mines, foundries, factories, and more
- Remove fumes, dust, smoke, and steam from poorly ventilated areas
- Safe for environments with explosive gases
- Fan blades are made of non-sparking cast aluminum
- Single and 3-phase models

Model	Type	Dia.™	HP	CFM High	Phase
B182027	Belt-Drive	12	3/4	1,444	3
B181934	Belt-Drive	24	3/4	6,903	3
B182031	Belt-Drive	42	2	20,700	3
B182052	Explosion Proof	18	3/4	3,050	1
B181952	Explosion Proof	27	1	9,400	1
B181977	Explosion Proof	42	1 1/2	18,960	1

294495

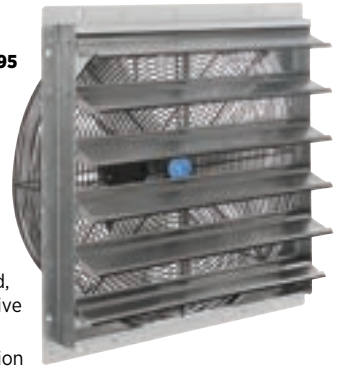

EXHAUST FANS WITH SHUTTER

- 120V AC, 1-phase totally-enclosed, permanently-lubricated direct-drive motor
- Provisions for hardwired installation
- Install on inside wall with no need for external framing
- Aluminum blades with sturdy steel wire guard,
- Meets OSHA standards, cUL- and UL-listed

Model	Fan Dia.™	HP	Speeds	CFM High
248448A	10	1/80	3	1,500
294495	12	1/12	1	2,150
294496	18	1/6	1	5,250
294497A	24	1/4	2	7,000
294498	30	1/4	1	8,000

EXCLUSIVE BRANDS

653226



ROOF VENTILATORS

- Designed for general ventilation needs in production or warehouse areas where efficient, quiet air flow is required
- Heavy-gauge steel propellers are standard
- Ruggedly-constructed steel curb cap including spun venturi section for efficient air flow

Model	Fan Dia.™	CFM High	HP	Voltage
653229A	24	7,425	1	230/460
653221	30	10,235	3/4	115/230
653232	36	20,500	3	230/460
653226	48	28,150	3	230/460
653227	60	44,600	5	230/460

EXCLUSIVE BRANDS

292656



INLINE DUCT FANS

- Provide air ventilation and circulation for residential, commercial, industrial applications
- Steel or rugged ABS plastic construction
- Backward-curved airfoil impeller for quiet operation, efficiency, and added pressure
- Most fans come pre-wired with mounting bracket

Model	Duct Dia.™	CFM High
292655	4	156
292656	6	235
292657	8	541
292658	10	630
292659	12	930

EXCLUSIVE BRANDS



292938

COMMERCIAL AIR SCRUBBERS & NEGATIVE AIR MACHINES

- Filter and remove airborne particulates
- Inhibit mold and mildew growth
- Can be configured to ventilate or extract air
- Sturdy rotomolded plastic housing

Model	CFM High	Speeds
292938	500	Variable
293052	1,000	1

BREATHE EASY WITH OUR AIR FILTER PRODUCTS

B2352441



B2318861



B2319107



AIR FILTERS

- Pleated Filters: Superior performance at a low price
- Pocket and V-Bank Filters: For oil mist, fume, and airborne contaminant collection
- Rigid Cell Filters: Medium- to high-efficiency
- HEPA Filters: Provide the highest level of filtration for healthcare, labs, etc.



B2319468
FILTER ONLY

B2318995



Model	H" x W" x D"	MERV	Pack Qty
B2319468	24 x 24 x 6	6	12
B2319479	36 x 36 x 6	6	12
B2352441	24 x 24 x 12	HEPA	1
B2318427	16 x 16 x 1	8	12
B2318320	24 x 24 x 12	8	12
B2318861	20 x 20 x 4	13	6
B2318889	25 x 20 x 4	13	6
B2318478	24 x 20 x 12	---	1
B2319107	24 x 12 x 10	9	10
B2319178	20 x 24 x 12	15	1
B2318995	12 x 24 x 12	15	2

246551



B

PORTABLE ELECTRIC HEATERS

- Ideal for use in factories, garages, workshops, and more
- Salamander-series features tubular steel frames and ergonomic handles for easy tilt adjustments
- Several sizes and heat output levels available
- CSA and cETLus listed

Model	Style	KW	Volts	Phase	BTU	W" x D" x H"
653558	A	10	240	1	34,120	21½ x 28 x 38½
653672	A	15	480	3	51,180	21½ x 28 x 38½
653671	A	15	240	3	51,180	21½ x 28 x 38½
653673	A	15	208	3	51,180	21½ x 28 x 38½
653670	A	15	240	1	51,180	21½ x 28 x 38½
246551	B	10.2	240	1	33,700	15½ x 22½ x 22½
246552	B	15	208	3	51,000	16½ x 24½ x 23
246553	B	30	480	3	101,350	18½ x 26½ x 24½

653558



A

B 246103



653557



A

246726



ELECTRIC UNIT HEATERS

- For factories, stores, warehouses, and other exposed areas
- Easy to install and service
- Maximum air flow via large, dynamically-balanced fan blades
- Totally-enclosed motors with permanently-lubricated bearings

PORTABLE HEATERS

- Radiant Panel or Portable options
- Perfect for spot-heating any cold area in your facility
- Lightweight and portable with carry handle
- Thermostat control
- 6'L, 3-conductor power cord

Model	BTU	Watts	Volts	W" x D" x H"
UNDER-THE-DESK RADIANT PANEL HEATERS				
246097	580	170	120	22 x 15 x 1
PORTABLE HEATERS				
653579	5,100	1,500	120	13 x 11½ x 13
246099	5,120	1,500	120	5¾ x 7¾ x 4¾
653557	5,120	1,500	120	12 x 11 x 15
246098	5,120	1,500	120	9½ x 6 x 16

Model	Style	Mount	KW	BTU	Volts	Phase	W" x D" x H"
653577	A	Horizontal	5	17,100	240/208	1	17 x 17 x 16
246726	A	Horizontal	7.5/4.7	25,600	240/208	1	15 x 15 x 13
246102	A	Horizontal	10	34,100	240	1 or 3	22 x 18 x 16
246725	B	Horizontal/Vertical	5	17,100	480	3	14 x 9 x 16
246104	B	Horizontal/Vertical	7.5	25,600	480	1 or 3	20 x 10 x 22
246103	B	Horizontal/Vertical	10	34,100	480	1 or 3	20 x 10 x 22
246132	B	Horizontal/Vertical	7.5	25,600	240/208	1 or 3	20 x 10 x 22
246133	B	Horizontal/Vertical	10	34,100	240/208	1 or 3	20 x 10 x 22
246134	B	Horizontal/Vertical	15	51,200	480	3	20 x 14 x 22
246727	B	Horizontal/Vertical	20	68,200	480	3	20 x 14 x 22

PROPANE & KEROSENE HEATERS

- Rugged construction
- Auto shut-off if power is interrupted or flame is extinguished
- Variable heat settings
- Proper ventilation required



B1145054



B2680588

PROPANE Model	BTU	Heating Area Sq. Ft.	Cylinder Size. Lbs.
246086	68,000	1,700	20-100
B1145057	125,000	3,000	20-100
B1145054	170,000	4,000	100-300

KEROSENE Model	BTU	Heating Area Sq. Ft.	Tank Cap. Gal.
B2255388	122,000	2,900	17
B2255387	180,000	4,100	17
B2680588	500,000	N/A	46

246662



SMALL GAS HEATERS

- Pushbutton ignition
- Mechanical tip over shutoff
- Convenient carry handle

Model	BTU	Coverage Sq. Ft.
246662	9,000	200
246635	10,500	525
B1145052	45,000	1,025

INFRARED GAS CERAMIC HEATERS

- Ideal for spot heating large areas
- Dimpled tile assembly for increased radiant efficiency
- Aluminum reflectors for maximum radiant output
- Energy-efficient direct-spark ignition system
- Gas shut-off safety control



B1735877

Model	BTU	Ignition Type	Minimum Mount H'	W" x D" x H"	Fuel Type
B1735877	22,000	Millivolt Standing Pilot	8	30 x 12 x 9	Propane
B1735879	25,000	Millivolt Standing Pilot	8	30 x 12 x 9	Natural Gas
B2093432	80,000	Direct Spark	14	27 x 24 x 8	Natural Gas
B2093433	120,000	Direct Spark	16	27 x 24 x 8	Natural Gas



B59715

STRAIGHT-TUBE INFRARED HEATERS

- Aluminum reflectors rotate 45° to direct heat where needed
- Heavy-duty cast iron burner with direct-spark ignition system
- 100% gas safety shut-off control
- Inspection sight glass, diagnostic monitoring light
- Quiet ignition
- CSA-certified

POSITIVE PRESSURE SYSTEM					VACUUM SYSTEM				
Model	BTU	Fuel Type	Tube L'	Minimum Mount H'	Model	BTU	Fuel Type	Tube L'	Minimum Mount H'
B59969	40,000	LP	10	9	B59715	50,000	LP	15	10
B59864	100,000	LP	30	13	B59872	100,000	NG	30	13
B59746	150,000	NG	40	14	B200339	125,000	NG	40	13
B59958	200,000	NG	60	16	B200342	175,000	LP	50	15

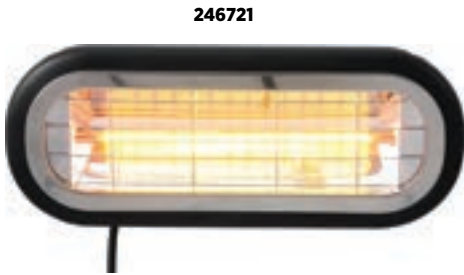

246721



246722



246471

PATIO HEATERS

- For outdoor dining and sitting areas
- Built-in overheat detection mechanism for added safety
- Most models are remote control-enabled for convenient operation from a short distance
- Select heaters can be wall or ceiling mounted or fixed to a stand

Model	Watts	Volts	Mount	Heat Coverage Sq. Ft.	L" x W" x H"
246721	1500	120	Wall/Ceiling	250	18 ³ / ₈ x 7 ¹ / ₂ x 3
246718	1500	120	Wall/Ceiling	250	35 ³ / ₈ x 5 ¹ / ₈ x 3 ¹ / ₂
246722	1500	120	Stand	250	33 ³ / ₈ x 5 ¹ / ₈ x 42-82
246720	1500	120	Wall/Ceiling	200	30 ³ / ₄ x 5 x 5 ³ / ₈
246723	1500	120	Stand	200	30 ³ / ₄ x 5 x 42-82
246719	2600	240	Wall/Ceiling	172	59 x 6 ⁵ / ₁₆ x 1 ¹ / ₄
246717	1500	120	Stand	170	19 ¹ / ₈ x 19 ¹ / ₈ x 11 ¹ / ₈

DRUM/TOTE HEATER BLANKETS

- Built-in thermostatic shutdown prevents overheating
- Insulated full-wrap design with adjustable straps for secure fit
- Barrel heaters work with plastic and metal drums, as well as drum cradles
- UL- and CSA-certified
- 120V, 6' power cord

Model	Control	Temp High F°	Watts High	L" x W"
DRUM				
246471	Fixed	100	800	47 x 16
246299	Adjustable	145	800	82 x 36
Model	Capacity Gallons	Temp Adjust to F°	Watts High	L" x W"
TOTE				
246554	275	145	1200	174 x 49
246555	330	145	1200	174 x 56



246112

246116

THERMOSTATS & HUMIDISTATS

- All are energy-efficient and cost-effective
- Types include programmable, non-programmable, and mechanical operation
- Plug-ins allow control of smaller window and portable ACs and heaters
- UL-, ETL-, and CSA-approved

Model	Thermostat Type	Stages	Control Range °F	Settings
246110	Mechanical Line Volt	1H	41 to 90	Manual
246111	Non-Programmable Low Volt	1H/1C	40 to 95	Manual
246116	Non-Programmable Low Volt	1H/1C	45 to 95	Manual
246117	Programmable Low Volt	1H/1C	40 to 95	5-1-1
246114	Plug-in	1H	40 to 95	Manual
246115	Plug-in	1C	40 to 95	Manual
Model	Plug-In Humidistats	Volts	Relative Humidity	
246112	Humidistat	120	30 to 90%	
246113	Dehumidistat	120	30 to 90%	

JANITORIAL & FACILITY MAINTENANCE

79-102

EXCLUSIVE BRANDS

240464



HEAVY-DUTY WASTE CONTAINERS

- Leak-proof seamless plastic allows for easy cleaning and handling
- Cans nest when empty
- Will not corrode, chip, crack, or peel
- Rugged, reinforced rolled-form top rim
- Optional lids and dolly available
- Available in a range of colors and capacities

Model	Description	Color Suffix
240456	10 Gallon Container	BN, GY, WH
240457	10 Gallon Flat Lid	
240458	20 Gallon Container	GY, WH, BN, YL, BL
240459	20 Gallon Flat Lid	
240460	32 Gallon Container	GY, WH, BN, YL, BL, RD, OR, BK
240461	32 Gallon Flat Lid	
240462	44 Gallon Container	GY, WH, BN, YL, BL, RD, OR, BK
240463	44 Gallon Flat Lid	
240464	55 Gallon Container	GY, WH, BN, YL, BL, RD, OR, BK
240465	55 Gallon Flat Lid	
240466BK	Dolly-Fits 20, 32, 44, 55	

261902



PLASTIC RECYCLING CONTAINERS

- Heavy-duty plastic resists dents and corrosion
- Designed to fit in tight spaces or along workstations
- Smooth surface makes for easy cleaning
- Built-in finger grips on top rim and handles for easy lifting and emptying

Model	Description	W" x D" x H"	Color Suffix
261902	23-Gallon Container	20 x 11 x 30	BL, BK, GY, RBL, RGN
261903	Paper Slot Lid	20 x 11 x 4	BL, GN
261904	Solid Lid with Handle	20 x 11 x 4	GY, GN
261905	Bottles & Cans Lid	20 x 11 x 4	BL, GN

THE RIGHT WASTE CONTAINER WITHOUT WASTING SPACE

240771



PLASTIC RECYCLING TOTES

- Durable impact-resistant plastic uses 35% recycled content
- Includes easy-grip handles and recycling decals on 2 sides
- Containers nest when empty and allow cross-stacking

Model	Gal. Cap.	W" x D" x H"
240771	14	19¾ x 15¾ x 13½
240772	18	23 x 16 x 14½

237279



HEAVY-DUTY MOBILE WASTE CONTAINERS

- Watertight construction with lid eliminates leaking and reduces odors
- Integral handles, reinforced rim and wear ridges
- Compatible with automatic arm lifters and semi-automatic bar lifters

Model	Gal. Cap.	Lb. Cap.	W" x D" x H"	Color Suffix
237279	65	230	25¾ x 26¾ x 42¾	BK, BL, GY
237281	95	335	26¾ x 33¾ x 46¾	BK, BL, GY

261940



261944



237634BK



237633



OUTDOOR SLATTED STEEL RECEPTACLES

- Flat-bar steel body discourages graffiti
- Durable powder coat finish provides premium corrosion protection
- Metal top band for extra strength
- Cans with access doors offer easy servicing
- Available in multiple colors, capacities and lid types

Model	Gal. Cap.	Dia." x H"	Lid
RECEPTACLES			
237725	24	23 x 36	Flat
237726	36	28 x 36	Flat
260803	24	23 x 41¾	Rain Cap
260804	36	28 x 41¾	Rain Cap
261944	36	28 x 42	Dome
641431	72	54½ x 36	Flat
641432	72	54½ x 41¾	Rain Cap
RECEPTACLES WITH ACCESS DOOR			
261940	36	28 x 42	Flat
261941	36	28 x 47¾	Rain Cap
261945	36	28 x 48	Dome

OUTDOOR STEEL MESH RECEPTACLES

- Rugged steel body reinforced with bands, vertical ribs, and curled edging
- Endures extreme climate conditions; ideal for outdoor use
- ADA-compliant

Model	Gal. Cap.	Dia." x H"	Color
237633	48	23 x 33	Galvanized
237634BK	48	23 x 33	Black
237634BL	48	23 x 33	Blue
237634GN	48	23 x 33	Green
237634RD	48	23 x 33	Red

OUR BEST TRASH AND RECYCLING CONTAINERS

261924BL



261926



STEEL THERMOPLASTIC-COATED RECEPTACLES

- Thermoplastic coating resists fading, mold, and vandalism
- Rugged 11-gauge steel frame
- Lid and base have a black powder coat finish for rust prevention
- Available in two patterns, three lid styles

Model	Style	Gal. Cap.	Dia." x H"	Lid
261924	Diamond	32	23½ x 30	Flat
261925	Perforated	32	23½ x 30	Flat
261926	Diamond	32	23½ x 40½	Rain Cap
261927	Perforated	32	23½ x 40½	Rain Cap
261948	Diamond	32	23½ x 40	Dome
261949	Perforated	32	23½ x 40	Dome

240716



ALUMINUM OPEN-TOP TRASH CONTAINERS

- Sleek, attractive satin finish resists blemishes
- Corrosion- and fire-resistant
- Made from heavy-gauge aluminum for long-lasting durability
- Large-diameter opening for waste disposal access
- ADA-compliant



Model	Dia." x H"	Gal. Cap.
240716	15 x 30	20
240718	18 x 32	35

STEEL WASTE RECEPTACLES

- 305 stainless steel is ideal for heavy-duty use
- Dual-entry swing lid keeps trash out of sight
- Door is attached to the receptacle for easy maintenance
- Folding retainer bands secure trash liners in place

Model	W" x D" x H"	Gal. Cap.
641268	14 x 14 x 35½	24
641269	19 x 19 x 38	40

641268



261877BL



261747BK



RECYCLING PLASTIC WASTEBASKETS

- Rounded corners provide extra strength
- Durable plastic body will not chip, rust, or dent
- Recycling wastebaskets include a large recycling logo
- Available in black or recycling blue

Model	Qt. Cap.	Color	W" x D" x H"
261747BK	13%	Black	11¼ x 8¾ x 12¼
261877BL	13%	Recycling Blue	11¼ x 8¾ x 12¼
261748BK	28%	Black	14½ x 10½ x 15
261878BL	28%	Recycling Blue	14½ x 10½ x 15
261749BK	41%	Black	15¼ x 11 x 19%
261879BL	41%	Recycling Blue	15¼ x 11 x 19%

641425SS



641423SS



STAINLESS STEEL OPEN-TOP RECEPTACLES

- Suitable for high-volume traffic areas
- Included bag-cinches to keep trash liners in place
- Durable construction with a brushed finish for a sleek appearance
- Slip-resistant base

Model	Style	Gal. Cap.
641423SS	Round	16
641424SS	Round	21
641425SS	Semi-Round	16
641442SS	Rectangular	8
641423SS	Rectangular	12

TRASH CAN LINERS

- Linear Low Density Polyethylene (LLDPE) bags are strong and resistant to puncturing
- Star seal design is virtually leakproof
- Available for a wide range of receptacle sizes
- Available in black and clear

Gal. Cap.	Type	W"x H"	Thick.	Pkg. Qty	Black	Nat/Clr
40-45	Medium-Duty	40 x 46	0.75 Mil	100	---	261766
40-45	Heavy-Duty	40 x 46	1.00 Mil	100	261763	---
40-45	Heavy-Duty	40 x 46	1.40 Mil	100	261764	670261
55-60	Heavy-Duty	38 x 58	1.40 Mil	100	261768	670271
55-60	Heavy-Duty	38 x 58	1.70 Mil	100	261769	670272
55-60	Super-Duty	39 x 58	2.50 Mil	75	670196	670200
95	Super-Duty	58 x 62	2.50 Mil	50	670197	670201



261763

EXCLUSIVE BRANDS



641413BL



641414BK



Dome lid protects container and contents from the elements



Includes handles for easy lifting and emptying

SQUARE PLASTIC WASTE RECEPTACLES

- Will not rust, dent, or chip
- Large 42-gallon capacity helps keep facilities clean
- Includes cinches to keep liners in place and hidden
- Choose from two colors, three lid styles

Model	Lid Style	Color
641413BK	Flat	Black
641413BL	Flat	Blue
641414BK	Dome	Black
641414BL	Dome	Blue
641540BK	Ashtray	Black

501986BG



705579BK



RANGER® CONTAINERS

- Structural molded polyethylene foam is designed to withstand extreme weather
- UV-stabilized to ensure long life in outdoor environments
- Ideal for fast food restaurants, parks and municipal sites
- Includes a permanently-attached hinged top



Hinged top opens easily for emptying

Model	Access	Color	W" x D" x H"	Gal. Cap.
501985	2 Doors	BG, BK	21½ x 21½ x 41	35
501986	2 Doors	BG, BK	24⅞ x 24⅞ x 41½	45
705579	4 No Doors	BG, BK	24⅞ x 24⅞ x 41½	45

EXCLUSIVE BRANDS

PERFORATED-STEEL RECEPTACLES

- Constructed of heavy-duty steel for indoor/outdoor use
- Attractive perforated design with solid steel middle ring
- Flat-top lid features a large-diameter opening
- Includes removable plastic liner and security cable
- Choose from 4 colors



641313

Model	Color	Dia." x H"	Gal. Cap.
641313	BK, BL, GY, SS	15½ x 34¾	20
641314	BK, BL, GY, SS	23½ x 41	55

EXCLUSIVE BRANDS

OUTDOOR ASHTRAYS

- Flame-retardant polyethylene housing keeps out rain and airflow
- Exclusive stainless steel ash plate provides a clean look
- Restricted opening keeps out non-cigarette waste
- Available in 5 colors



245133BG

Model	Color	Dia." x H"	Gal. Cap.
261391	BG, BK, GN, GY, RG	11 x 30	1½
245133	BG, BK, GN, GY, RG	15 x 39	5

EXCLUSIVE BRANDS

OUTDOOR STEEL ASHTRAYS

- Durable powder coat finish protects against burn damage
- Weather- and UV-resistant finish
- Oblong openings prevent rain and trash from entering
- Includes removable 4.5-gallon liner
- Choose Black or Gray



641447BK

Model	Gal. Cap.	Color
641447BK	4.5	Black
641447GY	4.5	Gray

REDUCE FATIGUE & WORRY CHOOSE THE RIGHT FLOOR MAT

The right floor mat can increase productivity by improving safety, minimizing fatigue, and easing chronic back and leg injuries. Special mats can protect sensitive electronics and offer sure footing in wet and slippery conditions.

ANTI-FATIGUE MATS

Reduce discomfort caused by standing on a hard floor for an extended period of time and help keep employees safe within your facility.



800529

DIAMOND PLATE ANTI-FATIGUE MAT

- Reduce back and knee strains
- Improve working conditions for employees
- Save your company in workers' comp claims and lost work days
- Help reduce insurance claims

DRAINAGE MATS

Mats built to withstand wet and dry work areas that will minimize slipping and are easy to clean

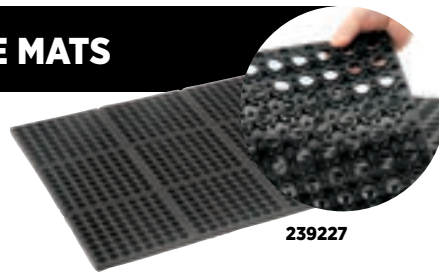

239227

APACHE MILLS PERFORMA 100N™ MODULAR DRAINAGE MAT

- Customize to both width and length with built-in connectors
- Drainage mat allows liquid and water to pass through matting

ENTRANCE MATS

Entry mats prevent dirt and debris from being tracked into your facility, and they absorb water & moisture to help reduce the risk of slips & falls.



B218777

M&A MATTING SUPERSCAPE™ SLIP-RESISTANT ENTRANCE MAT

- 3'x5' 100% Nitrile Rubber Mat
- Provides slip-resistant surface
- Molded tread-surface effectively scrape tough dirt and grime off shoes
- Earth friendly mat has 20% recycled Nitrile rubber
- Grease Proof

ANTI-STATIC MATS

Conductive runners allow your sensitive components to remain grounded and prevents static discharges from causing irreversible damage while offering a smooth work surface.



442427

WEARWELL® ELECTRICALLY-CONDUCTIVE DIAMOND PLATE OR SMOOTH MAT

- Nitrile rubber composite sponge base reduces worker fatigue

DIAMOND PLATE

- 3/16" vinyl diamond plate top surface comes with 1 grounding snap per mat
- 9/16" thick diamond surface offers 5 x 10⁵ to 1 x 10⁷ ohms resistance

SMOOTH

- 1/8" smooth vinyl surface comes with 1 grounding snap per mat
- 1/2" thick Smooth surface offers 1 x 10⁴ to 1 x 10⁶ ohms resistance

**FOR MORE OPTIONS INCLUDING:
See our Selection of Entrance, Chair, Sport, Heated, Kneeling and
Ground Protection Mats**



RUBBERMAID® CARTS & BINS THAT ARE MAID FOR EVERY JOB.



498164

PLASTIC DECK PLATFORM TRUCK

Its tough, high-impact honeycomb plastic construction is virtually maintenance-free and will not rust, dent, chip or discolor. It features a powder-coated, removable, cross-braced push handle and 8" thermoplastic rubber wheels (2 swivel, 2 rigid) for easy maneuverability. 48x24", 2000 Lb. Cap.



498402

LIGHT-DUTY PLASTIC TILT TRUCK

Designed for 1-person operation, this durable polyethylene truck efficiently handles industrial waste. It meets FDA and OSHA food and sanitary requirements, making it ideal for recyclable products. Seamless, smooth, ribbed-plastic construction cleans easily. Counterbalanced design helps to prevent "backing up" when tilting. 1 Cu. Yd. Cap, 850 Lb. Cap.

JANITOR CART WITH 25-GALLON VINYL BAG

Constructed of easy-to-clean, reinforced, smooth-walled plastic, it has compartments and hooks to organize equipment & supplies. A zippered yellow vinyl bag makes trash removal easy. Rolls on non-marking, 4" swivel casters and 8" diameter rear wheels. Bottom shelf holds a mop bucket or a 32-gallon Brute waste can. Wringer bucket and supplies sold separately.

239044BK



PLASTIC UTILITY CART

This handy, durable utility cart features rust-, dent-, chip- and peel-proof structural foam and an ergonomic push handle that improves control and worker safety. Molded-in storage compartments, holsters, hooks and notches increase usability. 500 lb. capacity. Four 5" casters, 45"L x 26"W x 33"H, 2-swivel & 2 fixed.

241559



B55835



HYGEN® Q560 17" QUICK CONNECT WET/DRY FRAME

Easy, one-step connecting mechanism for quick mop assembly and changeover. Thin, flat frame easily reaches under low objects for thorough cleaning. Works with optional HYGEN microfiber pads. 24" frame includes pull-type squeegee for water and debris collection. Sold 6 frames per case.

B55831



HYGEN® 18" MICROFIBER MOP

High-quality, ultra-fine microfiber removes bacteria, making cleaning quick and effective. Fibers pick up and hold dust, dirt, and grime. Hypoallergenic, lint-free, nonabrasive and color-coded to improve sanitization. Double-bound edges for durability. Pads are stain-resistant and machine washable. 12 pads/case.

B2246436



SLIM JIM RECYCLING STATION, LANDFILL/ MIXED RECYCLING

An adaptable recycling solution offers a front-of-house look with back-of-house functionality. Simple lid openings help patrons and staff sort recyclables more effectively. Components snap in place without the use of hardware. Includes two 23-gallon containers.

B3082558



VENTED WHEELED BRUTE CONTAINER

This 4-pack of gray 44-gallon Brute containers feature DuraTread never-flat wheels that allow you to move loads easier, even over rough terrain, and an ergonomic handle is designed to require less force when moving heavy loads up to 175 Lbs. Venting channels make lifting out liners easier, improving productivity and reducing the risk of injury.

“WET FLOOR” CAUTION SIGNS

- Protect employees from injuries on dangerous slippery surfaces
- Feature ANSI-compliant graphics
- Available in plastic and stainless steel
- Folds for storage



Model	Description
261725	English Plastic
261726	Multi-Lingual Plastic
641436	Multi-Lingual Stainless Steel

641436

MOP BUCKETS WITH WRINGER COMBO

- Maneuver around hard floor surfaces with ease
- Corrosion-resistant polypropylene
- Comfort grip handle for easy and efficient wringing
- With side-press or down-press wringer



260594

Model	Pressure
260594	Side
260595	Down

MOP HEADS AND HANDLES

- Mop heads constructed from blue blend for less unraveling, linting, and increased floor coverage
- Mop handle features plastic quick-change head that firmly grips mops
- Available in various styles and sizes



261830

261836

Model	Description	Material
261829	Medium Mop Head	Cotton/Rayon/Synthetic Blend
261830	Large Mop Head	Cotton/Rayon/Synthetic Blend
261836	60" L Handle	Fiberglass

ULTRA HIGH-SPEED FLOOR FINISH

- Ideal for frequent buffing or burnishing programs including propane machines
- Provides a long-lasting, mark-resistant finish with a brilliant deep gloss
- Four 1-gallon bottles per case

640403



PAPER SUPPLIES

- Designed to effectively meet everyday needs
- Choose from various styles of paper towels or 2-ply toilet tissue

670309



Model	Style	Ply	Sheet Size W" x L"	Pkg. Qty.
PAPER TOWELS				
670303	C-Fold	1 Ply	12¾ x 9¾	12
670309	Center Pull	2 Ply	7½ x 11	6
670305	Continuous	1 Ply	8	6
670307	Continuous	1 Ply	8	12
670302	Multi-Fold	1 Ply	9¾ x 9¾	16
BATHROOM TISSUE				
670308	Jumbo	2 Ply	3½	12

640403



CLEANING CHEMICALS

- Floor cleaners offer solutions for buffing, stripping, and cleaning hard floors
- General purpose cleaners and degreasers cut through just about everything
- Glass cleaner offers streak-free, non-ammoniated cleaning

Model	Description	Size	Case Qty.
FLOOR CLEANERS			
640403	Ultra High Speed Floor Finish	Gallon	4/1 Gal.
640404	Floor Cleaner & Deodorizer	Gallon	4/1 Gal.
640405	Super Concentrated Floor Stripper	Quart	6/1 Qt.
GENERAL PURPOSE CLEANERS & DEGREASERS			
640406	Heavy-Duty Cleaner & Degreaser	Gallon	4/1 Gal.
640407	Multi-Purpose Cleaner & Degreaser	Gallon	4/1 Gal.
GLASS & MIRROR CLEANER			
640414	Glass & Mirror Cleaner	Gallon	4/1 Gal.

CLEANING SOLUTIONS THAT HAVE THE FINAL SPRAY. WE CAN SUPPLY THAT.

boardwalk.

BOARDWALK® INDUSTRIAL-STRENGTH ALL-PURPOSE CLEANER

B2685773

- 1 gallon, unscented
- Deodorizes and cuts grease on most hard surfaces
- Concentrated formula can make over 32 gallons of cleaner
- Great for use on sinks, mirrors, windows, garbage pails, appliances, stainless steel and tile



YOUR ONE STOP SHOP FOR ALL YOUR CLEANING SUPPLIES



B2685737

BOARDWALK® 32-OZ TRIGGER SPRAY BOTTLE, 3-PACK

- Ideal for everyday cleansing needs
- Printed label in English & Spanish makes it easy to identify contents
- Bottles are imprinted with ultraviolet ink for superior chemical resistance and glossy finish

BOARDWALK® ULTRA-GERMICIDAL BLEACH

- Six 1-gallon bottles per case
- Cleans, deodorizes, disinfects, whitens, and removes stains
- Kills microorganisms including staph and strep bacteria, MRSA, E. coli, and Hepatitis B & C
- Use on ceramics, cement/concrete, enamel, fabric, glass, laminate, metal, plastic, NaOCl, dirt, bacteria, organic matter, & stains



B3037856



B2376330

BOARDWALK® NATURAL ALL-PURPOSE SPRAY CLEANER

- Twelve 32-oz. spray bottles per case
- Safely cleans dirt and grime
- Non-toxic: No harsh fumes or harmful chemicals
- Kills germs, cleans, and deodorizes hard surfaces without residue



B2686060

BOARDWALK® INDUSTRIAL-STRENGTH PORCELAIN BOWL & TILE CLEANER

- One 32-oz. spray bottle
- Quickly and effectively remove scale, calcium deposits, rust, oxidation and other discolorations
- Leaves a clean & pleasant scent behind
- Use on bathtubs, wash basins, shower stalls, drinking fountains, toilet bowls, urinals, stainless steel and other acid-resistant surfaces
- Ready-to-use out of the bottle

EXCLUSIVE BRANDS

641164



640955



HIGH-VELOCITY HAND DRYERS

- Touch-free operation provides sanitary hand maintenance
- Dries hands in 15 seconds or less
- Hands-under and hands-in styles available

Model	Description	Style	Color Finish
641591	Automatic Hand Dryer	Hands Under	Brushed Stainless
641164	Hand Dryer	Hands Under	Stainless
641565	Automatic Thin Hand Dryer	Hands Under	Brushed Stainless
640955	Vertical Hand Dryer	Hands In	Silver Plastic

DYSON AIRBLADE™ HAND DRYERS

- Dries hands hygienically in 12 seconds
- Touch-free operation
- Protrudes just 4" from the wall
- May be installed without additional recessing costs
- ADA-compliant

641167



Model	Color
641166	Sprayed Nickel
641167	White

EXCLUSIVE BRANDS

SANITARY NAPKIN & TAMPON DISPENSER

- ADA Compliant and free-dispensing option available
- Dual Dispensing allows user to choose their protection of choice
- Holds 15 Sanitary Napkins (No. 4 size box) and 22 tampons

B2310178



EXCLUSIVE BRANDS

641087



FEMININE HYGIENE

- Receptacles and dispensers are ideal for use in public restrooms
- Durable stainless steel construction

Model	Description	Type
641087	Sanitary Receptacle	Single Sided
B201930	Sanitary Vendor	Napkin/Tampon

HAND SOAP & SANITIZERS

- Soap has a light fragrance and contains vitamin E
- Hand sanitizer comes in alcohol and alcohol-free formulas
- Both kill 99.9% of common germs within 15 seconds
- Manual and automatic dispensers have large view windows
- Top-dispensing technology reduces the risk of leaks

Model	Description	Capacity	Color	Pkg. Qty.
DISPENSERS				
640807	Automatic Dispenser	1250 ml	Black	1
640808	Automatic Dispenser	1250 ml	White/Gray	1
Model	Description	Size	Pkg. Qty.	
SOAPS & SANITIZERS REFILLS				
640801	Luxury Foam Hand Soap	1250 ml	6	
641159	Antibacterial Foam Hand Soap	1250 ml	6	
640803	Instant Foam Hand Sanitizer	1200 ml	6	
640804	Instant Foam Alcohol Free Hand Sanitizer	1250 ml	6	
Model	Description	Dispenser Type	Fragrance	Pkg. Qty.
HAND SANITIZERS & SOAPS				
641460	Foam Hand Sanitizer - 62% Alcohol	32 oz. Pump	Linen	8
641459	Foam Hand Sanitizer - Alcohol Free	32 oz. Pump	Linen	8
641458	Spring Meadow Foam Hand Soap	32 oz. Pump	Floral	8
641457	Ultra Green Foam Hand Soap	32 oz. Pump	Fragrance Free	8

EXCLUSIVE BRANDS



640808



640801



641460

EXCLUSIVE BRANDS

B201858



640931



237637

TOILET SEAT COVERS & DISPENSERS

- Helps provide hygiene in public restrooms
- Available in stainless steel or plastic
- Paper seat covers come in pack of 5,000

Model	Description	Construction	Capacity
641155	Cover Dispenser	Plastic	500
B201858	Cover Dispenser	Stainless Steel	250
641157	Toilet Seat Covers	--	5,000

PAPER TOWEL DISPENSERS

- Variety of styles and sizes to suit public restrooms of any size or traffic level
- Manual paper towel dispensers accept various size towels
- Automatic dispenser is motion-activated with auto shutoff

Model	Brand	Description	Capacity	Construction
640931	Global Industrial	C-Fold/Multifold	350 C-Fold/525 Multifold Towels	Plastic
640902	Global Industrial	C-Fold/Multifold	400 C-Fold/525 Multifold Towels	Stainless Steel
640932	Global Industrial	Automatic Roll Towel	8" Non-Perforated Towel Rolls	Plastic
237637	ASI	Automatic Roll Towel	8" Non-Perforated Towel Rolls	Stainless Steel
640930	Global Industrial	Center Pull Towel	9" Center Pull Towel Rolls	Plastic

BREATHE EASY WITH FIXTURES AND SUPPLIES THAT KEEP THE BATHROOM STOCKED



B201853

640934



TOILET TISSUE DISPENSERS

- All dispensers mount easily in any public restroom stall
- Available in 1-roll, 2-roll, or 4-roll capacities
- Choose from plastic or stainless steel

Model	Brand	Dispenser	Cap./Rolls	Construction
640934	Global Industrial	Standard	Two 5¼"	Plastic
261192	Palmer Fixture	Standard	Four 5¼"	Plastic
B201852	ASI	Standard	Two 5¼"	Stainless Steel
640904	Palmer Fixture	Jumbo	One 9"	Plastic
640933	Global Industrial	Jumbo	Two 9"	Plastic
640903	Global Industrial	Jumbo	One 9"	Stainless Steel
B201853	ASI	Jumbo	Two 9"	Stainless Steel



640905



695750



641520

LIQUID & FOAM SOAP DISPENSERS

- Manual or automatic dispensers come in plastic or stainless steel
- Auto dispensers are motion-activated with locked battery compartment
- Countertop dispenser holds liquid soap or sanitizing gel

Model	Brand	Description	Model	Cap. ml	Mount
795507	Palmer Fixture	Manual Liquid Soap	Plastic	900	Wall
640905	Global Industrial	Manual Liquid Soap	Stainless Steel	1185	Wall
695750	Global Industrial	Automatic Liquid Soap	Plastic	1200	Wall
641520	Global Industrial	Automatic Liquid Soap/Sanitizer	Stainless Steel	700	Wall
641529	Global Industrial	Automatic Liquid/Gel Soap/Sanitizer	Plastic	350	Top

240742



260444



**PURELL®
HAND SANITIZERS**

- 62% ethyl alcohol formula contains no fluorinated chemicals
- Works in as little as 15 seconds
- Contains moisturizers to help keep skin hydrated and leaves hands soft and refreshed
- Touch-free dispenser maintains hygienic conditions

Model	Description
240742	TFX Touch Free Dispenser
240743	Hand Sanitizer Foam Refill
240744	Hand Sanitizer Refill
260440	Pump Bottle Dispenser
260444	Sanitizing Wipes - Canister

SHOP OUR HUGE SELECTION OF JANITORIAL & FACILITY MAINTENANCE SUPPLIES

EXCLUSIVE BRANDS

670235



MICROFIBER CLOTHS

- Constructed of quick-drying 80% polyester and 20% polyamide fiber
- Can be laundered and reused up to 500 times
- Microfiber texture increases effective surface area, allowing cloths to grab fine particulates
- Can be used wet or dry—no chemicals required

Model	Color	Application	Pkg. Qty.
670233	Green	Cleaning	12
670234	Red	Cleaning	12
670235	Blue	Cleaning	12
670236	White	Polishing	12

EXCLUSIVE BRANDS

640989



640992

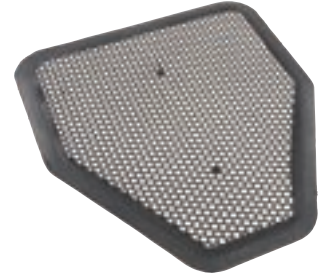

BATHROOM ODOR CONTROL

- Urinal screens contain organic deodorizing compounds that are stronger than traditional vinyl
- Deodorizing urinal and toilet mats neutralize odors and protect floors by catching and absorbing splashes and drips

Model	Description
640988	Urinal Screen
640989	Urinal Screen
640992	Deodorizing Urinal Mat
640993	Deodorizing Toilet Bowl Mat

EXCLUSIVE BRANDS

LOBBY BROOM & DUST PAN

- Lobby broom is cut and shaped for easy sweeping under tables, fixtures, and hard-to-reach areas
- Upright dustpan features a quiet hinge pin design and wheels on the back

261727



Model	Description	Dimension	Pkg. Qty.
261728	Lobby Broom	8" x 1" x 36"	6
261727	Upright Dust Pan	13" x 11" x 37"	6
261790	Broom/Dust Pan Combo Kit		

EXCLUSIVE BRANDS

641535



24" PUSH BROOMS WITH PLASTIC BLOCK & STEEL HANDLE

- Collect and move dust and heavy debris
- 3" polypropylene bristles
- Choose from rough, fine, or multi-purpose

Model	Style
641531	Fine Sweep
641533	Rough Sweep
641535	Multi-Sweep



STAINLESS STEEL HEPA WET/DRY VACUUMS

- Industrial-grade wet/dry vacuums feature a high-quality cartridge
- Additional drywall bag for fine dust
- Super quiet motors
- On-board tool kit
- No messy filters



WET/DRY SQUEEGEE VACUUM

- Corrosion- and impact-resistant rotationally-molded polyethylene
- 2-stage, 1.3 peak horsepower motor
- Includes 24.8"W front-mount squeegee assembly
- 8" diameter stair-climbing wheels
- On-board tool kit included



CANISTER VACUUM

- Lightweight and powerful
- HEPA filter removes 99.97% of air particles down to 0.3 microns
- Low operating noise, appropriate for public areas
- Washable sack filter & motor filter
- Meets OSHA filtration requirements

UPRIGHT VACUUM

- Features a 12" cleaning path, 50' power cord
- 6-position height adjustment
- Built-in magnet under the vacuum head picks up metal debris
- V-shaped side motor vents help provide greater airflow and improve performance



FLOOR BURNISHERS

- Heavy-duty 1.5 HP motor with handle-mounted circuit breaker for long life
- Safety lock-out switch on handle with thumb control
- Wheels allow tilt-and-roll mobility when not in use
- CSA listed



FLOOR MACHINES

- Low-speed operation for use on wet hard and tile floors
- Heavy-duty 1.5 peak horsepower motor
- Triple-planetary, all-steel gear box transmission for long life
- Safety lock-out switch on handle with easy access thumb control

Model	Speed
641311	2000 rpm
641310	1500 rpm

Model	Cleaning Path/Deck"	Speed
641253	20	180-320 rpm
641252	20	175 rpm
641251	17	175 rpm





641750

Blue LED Forklift
Pedestrian Safety
Warning Spotlight



641327



Large steering Wheel with Knob
for easy Maneuvering



49" Width Cleaning Path

AUTO RIDE-ON FLOOR SCRUBBERS

- Offers superior performance for heavy-duty cleaning and scrubbing applications
- Rotationally-molded polyethylene housing is corrosion- and impact-resistant
- Available in 40", 34", and 22" cleaning widths
- Over 4.5 hours of continuous runtime per charge

Model	Cleaning Path	Solution Tank	Pad Pressure Lbs.
641407	22"	28.8 Gal.	100
641245	34"	40 Gal.	111
641750	40"	40 Gal.	111

AUTO RIDE-ON SWEEPER

- Tackle heavy-duty cleaning jobs with this ride-on sweeper
- A large-capacity hopper and water tank minimize refill time
- Cleaning width up to 49" with both side brushes
- Shake vibration technology shakes dust off the filters to improve suction
- Battery runtime up to 5 hrs



641264

**WE HAVE THE SCRUBBERS,
YOU PROVIDE THE FLOORS.**



641751



641264



641244

AUTOMATIC SCRUBBERS

Automatic scrubbers feature rotationally-molded polyethylene tanks that are corrosion-and impact-resistant. Pad Assist models help the machine move forward by the friction of the scrub deck against the floor, but the machine needs to be tilted forward to engage spinning pad. Traction Drive/Self Propel models use an electric motor and require less effort to operate, allowing for reduced operator fatigue. Battery operated models have a 4.5 hour runtime and feature a battery energy management system with digital controller for longer runtime. Includes heavy-duty cast aluminum squeegee assembly. Large capacity solution and recovery tanks allow for low maintenance. 3 Year Limited Warranty; Lifetime Warranty On Housing.

Model	Cleaning Path/Deck"	Type	Power	Tank Cap. Gal. Sol./Rec.	Pad Pressure Lbs.	Water Lift"	Motor Brush	Vacuum
641751	13	Pad Assist	Battery, Two 12V 36Ah	2/4	66	18	0.34 HP	0.34 HP
641752	13	Pad Assist	Corded, 75'	2/4	66	25	0.16 HP	0.54 HP
641410	17	Pad Assist	Corded, 82'	9/10	77	102	0.5 HP	0.67 HP
641411	17	Pad Assist	Battery, Two 12V 80Ah	9/10	77	102	0.67 HP	0.7 HP
641250	18	Pad Assist	Corded, 82'	12/15	83	113	1 HP	1.6 HP
641263	18	Pad Assist	Battery, Two 12V 115Ah	12/15	83	113	0.75 HP	0.5 HP
261990	20	Pad Assist	Corded, 82'	12/15	83	113	1 HP	1.6 HP
641264	20	Pad Assist	Battery, Two 12V 115Ah	15/17	77	113	0.75 HP	0.5 HP
641244	20	Self-Propel	Battery, Two 12V 115Ah	15/17	77	113	0.75 HP	0.5 HP
641265	26	Self-Propel	Battery, Two 12V 115Ah	18/21	88	113	0.75 HP	0.5 HP
641840	34	Self-Propel	Battery	20/30.5	88	48	0.85	1 HP



641821



Available with or without Cabin



641820

CAT® C70RX AUTO RIDE-ON SWEEPER WITH A/C CABIN

Thanks to its large-capacity tanks and array of side and center roller brushes, this sweeper boasts a wide 70" cleaning path that cleans 204,514 sq. ft./hr. It is outfitted with technology that shakes dust off the filters and a front mister that provides both dust suppression and consistent suction. For safety, it has a rearview backup camera, turn signals, seatbelt, LED headlight, blue safety light, and a non-slip platform

CAT® FLOOR MACHINES, VACUUMS AND SWEEPERS. AVAILABLE FOR YOUR NEEDS.



641747

CAT® C40R AUTO RIDE-ON FLOOR SCRUBBER

With a 40" cleaning path, excellent brush pressure, a 220 RPM motor, and 73,518 sq. ft./hr of coverage, this scrubber has safety features that include a seatbelt, front warning light, front bumpers, and a non-slip platform.



641748

CAT® C49R AUTO RIDE-ON SWEEPER

Equipped with two independent side brushes that provide a wide 49" cleaning path, the CAT® C49R is ideal for use on concrete, ceramic tile, marble, and other hard surfaces; and it can handle ramps & inclines up to 18%. Self-cleaning filters and a front water mister provide dust suppression and consistent suction, while the seatbelt, bright LED headlight, and a non-slip diamond tread platform help keep the rider safe.

CAT® C26R AUTO RIDE-ON FLOOR SCRUBBER

- 26" cleaning path with a cleaning capacity of 37,600 sq. ft./hr
- Impact-resistant body, LED headlight, blue warning light
- 23-gallon solution and 26-gallon recovery tanks
- Rechargeable battery, USB charger, phone & cup holders
- For indoor use in dry conditions
- Detachable squeegee assembly with storage
- Comes assembled



641811



7" LCD Touch Screen



641746

CAT® C20T AUTO FLOOR SCRUBBER WITH TRACTION DRIVE

- 7" LCD touchscreen interface
- 20" cleaning path and multiple drive settings
- Polyethylene tanks are corrosion- and impact-resistant
- 100 lb. pad pressure with heavy-duty motor



641745

CAT® C20E ELECTRIC WALK-BEHIND CORDED AUTO FLOOR SCRUBBER

- Corrosion- and impact-resistant polyethylene tanks
- Wide 20" cleaning path for easy maneuverability
- Pad-assist feature helps pull the machine forward
- 110 lbs. brush pressure with heavy-duty motor
- Large 12-gallon solution and 15-gallon recovery tanks
- Heavy-duty cast aluminum squeegee



641757

CAT® C21V STAINLESS STEEL HEPA WET/DRY VACUUM

- HEPA filter and reusable filter bag captures fine dust
- Large 21-gallon tank capacity
- On-board tool storage and 33' GFCI power cord
- Two large rear wheels and two front casters
- Removable canister allows for easy maintenance



641759

CAT® C16V STAINLESS STEEL WET/DRY VACUUM

- Large 16-gallon capacity tank and dolly design increase productivity
- On-board tool storage, and 15' GFCI power cord



641758

CAT® C06V STAINLESS STEEL WET/DRY VACUUM

- On-board tool storage and 15' GFCI power cord
- Four swivel casters provide easy mobility
- 6.6-gallon tank capacity



©2022. Caterpillar CAT, CATERPILLAR, their respective logos, "Caterpillar Yellow," "Caterpillar Corporate Yellow," as well as corporate and product identity used herein, are trademarks of Caterpillar and may not be used without permission.



695753

ELECTRIC FOGGER

- Dispenses disinfectants in fine mist and fog to sterilize and disinfect
- Sprays 3,200+ sq. ft. in 10 minutes
- Adjustable range of 10 - 26'
- Easy to use; includes shoulder strap
- 16½' cord



695803

BATTERY-POWERED BACKPACK ELECTROSTATIC SPRAYER WITH CHARGER

- Delivers up to 4.2-gallons of disinfecting mist to sterilize offices, warehouses, mass transit, etc.
- Electrostatic technology applies a positive charge to the spray droplets so they adhere to surfaces like a magnet
- More uniform coverage than conventional sprayers

AIR MOVER WITH WHEELS

- Efficient drying power for floors, walls, and ceilings
- Industrial design has a 1 HP motor
- 3 speeds, 3 height adjustments
- Integrated wheels



641764

AXIAL AIR MOVER

- Speeds water evaporation time
- Designed for construction and water remediation-related projects
- ½ HP motor, 1,550 CFM
- 2 speeds, 3 height adjustments



641765

CHECK OUT OUR FULL LINE OF FLOOR MACHINES AND VACUUMS



641770

FLOOR DRYER

- Speeds drying of floors, walls, and ceilings
- ¾ HP motor
- 3 speed variations
- Low profile design allows for stacking

641763



AIR MOVER

- ½ HP motor
- 2 speed variations offer efficient levels of drying for floors, walls, and ceilings
- Provides a fast response with a low power draw
- 3 height positions



641767

LOW PROFILE AIR MOVER

- Provides a fast response with a low power draw
- Cuts drying time of floors, walls, and ceilings
- Low-profile design allows stacking of multiple units for transport
- Quiet operation

641769



VERTICAL FLOOR DRYER/BLOWER

- Speeds up water evaporation time
- Compact, portable solution for drying carpets, upholstery, and hard floors
- Provides a fast response with a low power draw
- Quiet operation

B37856



B37751



B37560



B686420



B686364



B686489



KRYLON® AEROSOL PAINTS

- Enamels and marking paints formulated for various industrial maintenance and touch-up applications
- Dries to the touch in 12 minutes or less
- Ideal for indoor and outdoor use

Model	Type	Color	Size	Pkg. Qty.
B37856	Acrylic Lacquer	Semi-Flat Black	12 oz. Can	6
B37408	VT Alkyd Formulation	Black	10 oz.	12
B37751	Water-Based	Orange	17 oz.	12
B37752	Solvent-Based	Orange	17 oz.	12
B37397	General Primer	Red	10 oz.	12
B37560	High Heat	Gray	12 oz.	6
B37399	Flat Enamel	White	10 oz.	12

RUST-OLEUM® AEROSOL PAINTS

- Rust-preventative enamel aerosols provide corrosion protection with easy, one-coat coverage
- Tough, professional finish with superior resistance to chipping, cracking, and peeling
- Withstands heat up to 200°F

Model	Color	Size	Pkg. Qty.
B686420	Black	15 oz.	6
B686155	Black	10 oz.	6
B3084930	Blue	17 oz.	12
B686563	Stainless Steel	14 oz.	6
B686521	Silver Aluminum	20 oz.	6
B686364	Safety Red	20 oz.	6
B686489	Yellow	16 oz.	6

WATERPROOF AND PRIMER PAINTS

- Waterproof formulas are ideal for all interior and exterior masonry
- Extreme formula has an anti-mildew element
- B-I-N® is a shellac-base primer sealer for interior and spot exterior use
- Cover-Stain® is an oil-based interior/exterior primer

B762583



B762580



B2094110



Model	Type	Size	Coverage	Color	Pkg. Qty.
B762583	EXTREME Masonry Waterproofer	1 Gal.	75-100 Sq. Ft.	White	2 Cans/Case
B762580	Latex Base Masonry Waterproofer	1 Gal.	75-100 Sq. Ft.	White	2 Cans/Case
B2094110	Zinsser® High Hide Cover-Stain® Primer	1 Gal.	74-199 Sq Ft.	White	1 Pail

184274



B1016456



B34754



B2939580



MASKING TAPE

- Masking tape comes in various adhesions and formulas for general and high-temperature painting, packaging, labeling, maintenance, etc
- Easy-to-stick masking tape conforms to rough surfaces such as stucco, concrete, wood, and brick

Model	Dimensions	Pkg. Qty.	Color
184274	1" x 60 Yards	36	Tan, Blue, Red, Black
B34754	1.89"W x 60 Yards	24	Tan
B2939580	24mm x 55m	48	Yellow, Blue, Pink
B1016456	1.89" x 60 Yards	12	Green

B2337106



B49987



B334976



640292



B335059



MULTI-USE LUBRICANTS

Specialty lubricants range from multi-purpose WD-40 to synthetic NLGI Grade 2 heavy-duty lubricants with PTFE to industrial lubricants designed specifically for chains, gears, or electrical components and connectors.

Model	Container Type	Size	Pkg. Qty.	Lubricant Type
640292	Drum	55 Gal.	1	Synthetic
B335059	Drum	400 lb.	1	Synthetic
B2337106	Aerosol Can	12 oz.	12	Petroleum Oil
B334961	Disposable Tube	1cc	5000	PTFE
B49987	Aerosol Can	12 oz.	12	Synthetic
B334976	Pail	30 lb.	1	Silicone

JANITORIAL & FACILITY MAINTENANCE SUPPLIES

B2277883



B2337102



B49953



640949



640946



640951



B173508



WD-40® SPECIALIST® AEROSOL LUBRICANTS

These lubricants are formulated for specialty applications, including engine parts, cables, pulleys, high-temperature settings, electrical connectors, and other parts and equipment. For use on various surfaces.

Model	Description	Size	Pkg. Qty.
640951	Machine & Engine Degreaser Foaming Spray	18 oz.	4
640946	Rust Release Penetrant	11 oz.	6
640947	Water Resistant Silicone Lubricant	11 oz.	6
640948	Protective White Lithium Grease	10 oz.	6
640949	Dirt & Rust Resistant Dry Lube PTFE Spray	10 oz.	6
640950	Electrical Contact Cleaner Spray	11 oz.	6

FOOD-GRADE LUBRICANTS

Synthetic H-1 food-grade grease and silicone lubricants provide resistance from friction, wear, water, and stain for parts and equipment in the food industry, where petroleum-based products and other organics would contaminate. Select formulas are effective for extreme temperatures.

Model	Brand	Lubricant Type	Container Type	Container Size	Pkg. Qty.
B2277883	CRC	Non-Drying Film	Aerosol Can	10 oz.	12
B49953	Sprayon	Food-Grade Silicone	Pail	5 Gal.	1
B2337102	CRC	NLGI #2 Grease	Aerosol Can	10 oz.	12
B762613	Sprayon	Food-Grade Silicone	Aerosol Can	12 oz.	12
B49952	Sprayon	Food-Grade Silicone	Aerosol Can	12 oz.	12
B2277881	CRC	Food-Grade Mineral Oil	Aerosol Can	16 oz.	12
B173508	Tri-Flow	NLGI #2 Grease	Tube	3 oz.	6

EXCLUSIVE BRANDS



PORTABLE STRAIGHT-LEG POP-UP CANOPIES

- Sturdy beam-welded tubular steel frame with high-performance synthetic joint components
- Bonded with DuPont™ thermoset powder coat to prevent chipping, peeling, rust, and corrosion
- Four-point height adjustable legs
- Polyester fabric cover treated with fade blockers, anti-aging, and anti-fungal agents
- Double-stitched polyurethane lining for optimal water-resistance and drip-free seams
- 50+ UPF rating blocks more than 98% of harmful UV rays
- Available in white, black, green, red, blue, and tan

Model	L' x W" x H"	Leg Style
602191	10' x 10' x 10'11"	Straight
602190	10' x 10' x 8'11"	Slanted



WEATHERSHIELD COMMERCIAL CANOPIES

- Quick and easy assembly on any surface
- EZ-Lock slip fittings mean less building time
- 14-gauge, 1.66" OD triple-galvanized structural steel tubing
- 12.5 oz. premium covers

Model	L' x W" x H"	Cap. Cu. Ft.
B354155	20' x 10' x 9'6"	1932
B354238	30' x 18' x 11'6"	6261
B354529	40' x 24' x 13'	12633



AWNTECH DOME AWNINGS

B1972273

- Engineered for heavy wind and snow loads
- Commercial and residential applications
- Aluminum frame, very easy to assemble and install
- 100% solution-dyed, rust-, fade-, and mildew-resistant acrylic fabric

Model	W" x D" x H"	Projection"	Color
B1972273	40½ x 20¼ x 31	20¼	Gray
B2013977	52½ x 26¼ x 33¼	26¼	Burgundy
B2014033	64½ x 32¼ x 39¼	32¼	Navy



B1972367

AWNTECH RETRACTABLE AWNINGS

- Heavy-duty retractable awning with manual operation or motorized operation
- Multi-chamber stainless steel-cabled lateral arms and adjustable pitch
- Structural steel and aluminum frame, white powder coat finish
- 100% solution-dyed and rust-, fade-, and mildew-resistant acrylic fabric

Model	W" x D" x H"	Projection"	Type
B1972367	120 x 96 x 10	96	Motorized
B1972691	120 x 96 x 10	96	Manual



B457038

STEEL CARPORTS

- Long-lasting vinyl coating over galvanized steel
- Use as a carport or as a patio cover for shelter from the elements
- Appealing single-tone aesthetics in eggshell to complement building exteriors
- DIY assembly with pre-cut and pre-drilled parts

Model	L' x W'
B457168	10 x 10
B457038	20 x 10



269939

RUBBERMAID® SHEDS

- Great for storing patio, lawn, and gardening tools and supplies
- Leak-, dent-, and weather-resistant
- Heavy-duty impact-resistant flooring
- Padlockable door

Model	Shed Style	Outside W" x D" x H"	Cap. Cu. Ft.
269939	Horizontal Split Lid	55 x 28 x 36	18
269937	Vertical	30 x 25 x 72	17
269938	Horizontal Slide Lid	55 x 28 x 36	18
704501	Horizontal	60 x 32 x 47	32
602309	Vertical	52 x 31 x 81	53



269418

STEEL STORAGE BUILDINGS

- Steel construction provides maximum protection and strength
- Included lag-down plates for secure installation
- Contoured steel roof drains water and holds snow
- Steel frame with powder coat finish

Model	Description	Openings
269419	Smokers Shelter	Right & Left Front
269418	Storage Building w/Doors	Front w/2 Doors

SUNCAST® STORAGE SHEDS

- Durable, multi-wall resin construction
- Easy maintenance
- Padlockable door
- Reinforced floor supports heavier items and equipment



B2055966

Model	Style	Overall Dimensions W" x D" x H"	Cap. Cu. Ft.
B2055966	Horizontal	53 x 32½ x 45½	34
298462	Horizontal	70½ x 44½ x 52	70
298459	Vertical	32½ x 25½ x 72	22
298460	Vertical	53 x 32½ x 69½	54



240574

OUTDOOR STEEL STORAGE SHEDS

- Building construction is ideal for keeping valuable items secure
- Wooden floor keeps product dry and off the ground
- Built-in rain gutters allow for controlled water drainage
- Assembled building may easily be moved with forklift

Model	Overall W x D x H	Door Opening W x H
240574	9'2" x 6'6" x 7'1"	3'9" x 6'2"
240575	9'2" x 12'11" x 7'1"	3'9" x 6'2"

SUNCAST® STORAGE BUILDINGS

- Steel-reinforced resin construction
- Reinforced floor supports heavy equipment
- Includes skylights, door windows, and corner shelves
- Padlockable metal lever handles



298465

Model	W x D x H	Cap. Cu. Ft.
298465	8' x 7' x 8'6"	378
298466	8' x 10' x 8'6"	574

EXCLUSIVE BRANDS



534736



534554



534553



B363079



B326441



B363077



501232

SPRAYERS

Model	Description	Capacity Liters
534736	All-Purpose Handheld Sprayer	2
534553	Commercial Duty Manually Operated Backpack Sprayer	15
534554	Commercial Duty Battery Operated Backpack Sprayer	15

SHOVELS & SCRAPERS

Model	Description	Blade Size
B363079	Union Tools Poly Combo Snow Shovel	18"
B363077	True Temper Ergonomic Snow Shovel	18"
B326441	True Temper #12 Poly Scoop	14.37"
501232	Razor-Back All Purpose Scraper	7"



640788



B2375082



B393545



B2375072



535501



534831



534756



535682

SPREADERS, VACUUMS & WHEELBARROWS

Model	Description	Capacity
640788	Global Industrial Universal Spreader	100 lbs.
B2375082	Agri-Fab Broadcast Tow Behind Spreader	175 lbs.
B393545	Jackson Steel Contractor Wheelbarrow	6 Cu. Ft.
B2375072	Agri-Fab 32 Chip-N-Vac Tow Behind Lawn Vacuum	32 Cu. Ft.

LANDSCAPING TOOLS

Model	Description	Size
535501	EGO 56V Self Propelled Push Lawn Mower Kit	21"
534831	EGO 56V Battery Powered Zero Turn Lawn Mower Kit	42"
534756	EGO 56V Cordless Chain Saw Kit	18"
535682	EGO 56V 145MPH 600CFM Cordless Backpack Blower Kit	-

"U" BIKE RACKS

- Design eliminates sharp edges and allows double-sided bike attachment
- Use more than one rack to store multiple bikes
- Works in any outdoor environment
- Made to last using 1½" dia. x .098" thick tubular steel
- Add color suffix: (GN), or Black (BK)



Model	Description
442804M	Above Ground Mount
442804G	Below Ground Mount

VERTICAL BIKE RACK STORAGE

- Vertical mount occupies less space
- 4-bike mounts to hold up to 4 bikes
- Quick bike mounting and retrieval
- Flange-type floor mount for firm stability
- Made of durable steel with black finish



Model	Description	Lockable
670514	Bike Rack	Non Lockable
670515	Fat Tire Bike Rack	Non Lockable
670513	Bike Rack	Lockable
670516	Fat Tire Bike Rack	Lockable

WE CARRY A FULL LINE OF OUTDOOR STRUCTURES & STORAGE

WAVE BIKE RACKS

- Rugged 12-gauge steel keeps bicycles secure
 - Designed without sharp edges for safety
 - Polyester powder-coated finish
 - Available in 3 mount styles including flange (M), below ground (G), and free standing (F)
 - Two color options: Green (GN), Black (BK)
- To order: Base Model + Mount + Color



Base Model	Bike Capacity	Mount	Color
652778	5-Bike	G, M, F	GN, BK
652779	7-Bike	G, M, F	GN, BK
652777	9-Bike	G, M, F	GN, BK



GRID BIKE RACKS

- Powder coat steel
- 1½" diameter tubular frame with ¾" diameter bike grid
- Available in single-side or double-sided options
- Easy assembly

Model	Description
652770	5-Bike, Single Sided
652771	9-Bike, Single Sided
652772	10-Bike, Double Sided



SEATING FROM FLASH FURNITURE ISN'T A FLASH IN THE PAN.



PLASTIC FOLDING CHAIR

- Commercial Grade Black Plastic Folding Chair for indoor or outdoor events
- 650 lb. Weight Capacity
- Easily stacks 50 high from the floor for nesting storage or floor maintenance; Folded Size: 17.5"W x 2.5"D x 38.25"H
- Dry Assisting Drain Holes prevent spills or rain from pooling in the seat
- 18 Gauge Steel Frame and Double Support Braces
- Powder Coated Frame Finish
- Non-Marring Floor Caps
- Portable heavy duty folding chair for multiple uses



B1105791

RESIN FOLDING CHAIR WITH VINYL SEAT

- Commercial Grade Resin Folding Chair
- 1000 lb. Weight Capacity
- Lightweight Design for storage and portability
- UV Stabilized Polypropylene Resin resists fading from sun exposure
- Removable Waterproof Vinyl Seat with CAL 117 Fire Retardant Foam
- Folded Size: 17.5"W x 2.25"D x 35"H
- Anti-Static prevents unwanted static discharge



B1105817

Model	Cap. Lbs.	Type	Folded W" x D" x H"
B1105791	650	Plastic	17 x 2½ x 38¼
B1105817	650	Plastic	17 x 2½ x 38¼

ANTIMICROBIAL BARIATRIC RECEPTION CHAIR WITH ARMS

- 1500 lb. Static Weight Capacity
- Stack Quantity: 10
- Brown Antimicrobial Fabric Upholstery
- 2.5" Thick Foam Padded Seat
- CAL 117 Fire Retardant Foam
- 18 Gauge Steel Frame
- Silver Vein Powder Coated Frame Finish with Plastic Floor Glides
- Plastic Bumper Guards protect finish when stacked
- Designed for high traffic commercial use



B2334152

24 HOUR BIG AND TALL LEATHER EXECUTIVE CHAIR

- Multi-shift task chair is designed for extended use
- Accommodates larger and taller body types
- 500 lbs. Capacity
- The high back extends to the upper back for greater lumbar support
- The tilt lock mechanism offers a comfortable rocking/reclining motion
- Double padded, contoured seat dissipates pressure points for greater comfort
- Swivels 360 degrees
- The pneumatic adjustment lever easily adjusts the seat to your desired height
- Heavy duty metal base



B2256278

FURNITURE & DÉCOR

104-119

EXCLUSIVE BRANDS

INTERION® MID-BACK MESH OFFICE CHAIRS

This ergonomic task chair has a nylon mesh back for cool, ventilated, and supportive comfort. Built-in lumbar support provides added back comfort. Additional features include a ratchet-back height adjustment, seat & arm height adjustment, and your choice of fabric or vinyl seats in four colors.

277436



WITH ARMS			ARMLESS		
Model	Seat Material	Seat Color	Model	Seat Material	Seat Color
277436	Fabric	Black	695644BK	Fabric	Black
277436RD	Fabric	Red	695644RD	Fabric	Red
277436GY	Fabric	Gray	695644GY	Fabric	Gray
277436BL	Fabric	Blue	695644BL	Fabric	Blue
277436V	Vinyl	Vinyl	695644V	Vinyl	Vinyl

INTERION® ANTIMICROBIAL HIGH-BACK GAMING CHAIRS

This generously-padded chair is rated for 8-10 hours of comfort. Antimicrobial leather resists bacteria, mold, and mildew. The high back and adjustable headrest, armrests, and lumbar pillow provide ergonomic support. Available with full recline. CAL 117-certified.

695854RD



Model	Back Height"	Back Tilt	Seat Color
695853GY	32½	Full Recline	Gray
695853BL	32½	Full Recline	Black
695853RD	32½	Full Recline	Red
695854GY	29½	Synchro Tilt	Gray
695854BL	29½	Synchro Tilt	Blue
695854BK	29½	Synchro Tilt	Black
695854RD	29½	Synchro Tilt	Red

INTERION® EXECUTIVE CHAIRS

This chair features soft bonded-leather upholstery with an antimicrobial surface that resists bacteria, mold, and mildew. Pneumatic mechanism adjusts seat height and the tilt-tension knob adjusts back tilt tension and locks it in place. BIFMA- and GREENGUARD-certified.

HIGH-BACK MESH OFFICE CHAIRS

Heavy-duty construction supports users up to 450 lbs. Breathable mesh back and thickly-padded black mesh fabric seat provide superior comfort. Sturdy aluminum base with gunmetal finish and five dual-wheel casters for easy mobility. Pneumatic seat height-adjustment.

277514



450 lb. Capacity

Item	Type	Seat Range	Weight
277514	Fabric	18½" - 21¼"	450 lbs
248623	Fabric	17¼" - 21"	275 lbs
248623H*	Fabric	17¼" - 21"	275 lbs
248622	Mesh	17¼" - 21"	275 lbs
249051	Leather	17¼" - 21"	275 lbs
B251196	Fabric	18" - 21½"	250 lbs

* Includes Headrest

INTERION® ERGONOMIC CHAIRS

Designed for comfort, this breathable mesh chair has a height-adjustable back and lumbar support. Both seat and back recline separately, and seat depth adjusts for users of any height. Armrests and headrest are adjustable, and headrest can be removed.

695545



Model	Seat Material	Seat Color
695545	Mesh	Black
695544	Mesh	Gray

277374



248626



Model	Seat Material	Seat Color
277374	Bonded Leather	Black
248626	Bonded Leather	Black

INTERION® LEATHER UPHOLSTERED CHAIRS WITH RIBBED SEAT & BACK

Upgrade your conference room or office setting with this aluminum base bonded leather chair. The ribbed antimicrobial surface resists bacteria, mold, and mildew. Built-in lumbar support, dual-paddle seat raise/tilt controls, and padded armrests provide customized comfort. ANSI, BIFMA, GREENGUARD certified.



695503-AM

695618BK



695618GY



INTERION® OFFICE CHAIRS

Armless task chair is upholstered in a soft fabric with a seat cushion. Chrome base adds a contemporary feel. Pneumatic height-adjustment and tilt tension-control knob with back lock option.

Model	Seat Material	Seat Color
695618BK	Fabric	Black
695618GY	Fabric	Gray



695615-AM

500 lb. Capacity

INTERION® ANTIMICROBIAL 24-HOUR CHAIR

Designed to provide maximum comfort for those who need to sit for long periods of time, this leather chair has an antimicrobial coating that resists bacteria, mold, and mildew. BIFMA-rated for a 500 lb. capacity. Seat-height and back-tilt has tilt tension control and lock.

SUCCESSFUL SEATING FOR ALL SITUATIONS

INTERION® BANQUET CHAIRS

Padded chairs offer comfortable seating for banquets, meetings, or other gatherings. 18-gauge steel frame, 2" thick foam cushioning with fabric or vinyl upholstery; waterfall seat. May be stacked up to 10 high. Black.



695862

695493

Model	Seat Material	Seat Color	Seat Thickness
695493	Vinyl	Black	2"
695494	Fabric	Black	2"
695862	Vinyl	Black	2"
695863	Vinyl	Black	2 1/2"

INTERION® OFFICE CHAIRS

Ergonomic task chairs feature multifunctional mechanisms that allow independent seat and back tilt adjustments. Adjustable arm rests, Class 3 gas lift. The 5-legged base has heavy-duty nylon casters. BIFMA- and CAL 117-certified.



695619

Model	Seat Material	Seat Color	Type
695619	Fabric	Black	Ergonomic
516123	Vinyl	Black	Antimicrobial
695505	Fabric	Black	24 Hour



695540



324501BK



607864GY

INTERION® PLASTIC FOLDING CHAIRS

Lightweight plastic chairs are easy to set up and take down. Comfortable contoured seat and back are stain-resistant and suitable for indoor or outdoor use. Its steel frame has two cross braces for stability and under-seat cross braces for strength.

Model	Seat Material	Seat Color
695540GY	Resin	Gray
B449364	Resin	Light Gray
695540	Resin	White

INTERION® STEEL FOLDING CHAIRS

Folding chairs are available in all-steel, or with vinyl or fabric seat and back. All have contoured backs for comfort, and a scratch- and chip-resistant powder coat finish. Welded leg braces keep chair rigid and aligned. Safety hinges eliminate pinch points.

Model	Seat Material	Seat Color
607864BK	Fabric	Black
324501BK	Steel	Black
607863BK	Vinyl	Black
607864BG	Fabric	Beige
324501BG	Steel	Beige
607863BG	Vinyl	Beige
607864GY	Fabric	Gray
324501GY	Steel	Gray
607863GY	Vinyl	Gray



921397BK



INTERION® MERION VENTED BACK MOLDED CHAIRS

Contoured back support design and ventilating slot for comfortable seating. Polypropylene shell with tubular steel frame endures long term use. Non-marring glides. Stacks compactly at 2"H increments. Seat: 17"W x 16"D x 16"H and 17"H from floor. Sold 4 per carton, all same color and style. 2 Year Limited Warranty.



250606BLA

250606BKA

INTERION® VENTILATED PLASTIC STACK CHAIRS

A stacking chair combines convenience with comfort. The contoured back is vented for air circulation and the seat has a comfortable waterfall edge. Tubular sled base adds stability, and interlocking brackets let you join chairs in rows.

Model	Seat Color
250606BKA	Black
250606BLA	Blue



B449424



INTERION® STACKING CHAIR WITH MID BACK

Interion® Stack Chairs has an 11mm steel rod chrome plated frame with textured polypropylene seat and back. Reinforced underseat ribbing for support. The chairs can be stacked up to 40 high. Easy lift handle allows strong grip when moving chairs. Protective floor glides guard against skidding. 10 Year Limited Warranty. Come in packs of 4. MAS Certified Green. ANSI/BIFMA Certified.



277431



250801

INTERION® CHAIR CARTS

Stack folding chairs quickly and transport them to storage smoothly with these sturdy steel carts and trucks. Non-marring heavy-duty casters.

Model	Capacity	For use with	Style
250801	12 Chair	Stacking Chairs	Vertical Stack
277435	36 Chair	Folding Chairs	Horizontal Stack
B678987	84 Chair	Folding Chairs	Hanging
277431	35 Chair	Folding Chairs	Vertical Stack
B2099151	50 Chair	Folding Chairs	Vertical Stack



250626

INTERION® 5-WAY ADJUSTABLE ERGONOMIC STOOLS

Seat and back tilt-adjustments, pneumatic seat-height adjustment, and an adjustable foot rail add up to optimal comfort for hours of sitting. Easy-to-clean, puncture-resistant polyurethane with a high-density foam core.



695262RD

INTERION® MESH-BACK STOOLS

Perfect for office, warehouse, training area, and more, this ergonomic stool has a breathable nylon mesh back with built-in lumbar support, a padded seat, and height adjustment. The arms adjust up and down and side to side. Available in four fabric colors or black vinyl.

Model	Seat Material	Seat Color
695262	Fabric	Black
695262BL	Fabric	Blue
695262GY	Fabric	Gray
695262RD	Fabric	Red
695263	Vinyl	Black



695641GY

695641BK

INTERION® ANTIMICROBIAL BONDED LEATHER MODERN RIBBED EXECUTIVE STOOLS

Thick cushioned seat and back provide proper support throughout your work day. Soft bonded leather upholstery has an antimicrobial surface that resists bacteria, mold, and mildew. Padded arm rests, pneumatic height adjustment. BIFMA- and GREENGUARD-certified.

Model	Color	Seat H"
695641BK	Black	25¼ - 32¼
695641GY	Gray	25¼ - 32¼



695725-30-GY

695725-24-BK

INTERION® STEEL SHOP STOOLS

These stackable steel stools complement traditional or modern décor. Available in bar or counter height, they're suitable for indoor/outdoor use. The seat cut-out allows easy carrying and the lower brace adds support and doubles as a footrest.

Model	Color	H"
695725-24-BK	Black	24
695725-24-GY	Silver	24
695725-30-BK	Black	30
695725-30-GY	Silver	30

INTERION® ACTIVE SEATING STOOLS

These stools have a sturdy base and a seat that moves and leans with your body. Designed for height-adjustable or standing desks, these stools engage major muscles and discourage slouching. Pneumatic height-adjustment. Fabric or synthetic leather seat options.

Model	Color
695613BK	Black
695613GY	Gray
695613BLT	Black Leather



695613BK

INTERION® STEEL SHOP STOOLS

Ideal for shops, classrooms and art studios, these 18-gauge steel stools come with or without backs, with hardboard or padded seat options. Footrest ring improves stability and comfort.

BACKLESS			
Ht"	Gray	Black	Style
24	B2157619	B957804	Hardboard
24	B2222429	B2217231	Vinyl Padded
WITH ADJUSTABLE HEIGHT AND BACKREST			
18-26	244870	B1574494	Hardboard
18-26	244872	B2217147	Vinyl Padded



B957804



244872



INTERIOR® PLASTIC FOLDING TABLES

Sturdy enough for permanent use, lightweight enough for temporary needs, this durable table is made of moisture- and stain-resistant polyethylene. Reinforced heavy-gauge 1-1/8" steel tube frame folds in seconds for a compact storing thickness of 1 3/4". BIFMA-tested.

Model	L" x W"	Color
506750	72 x 30	White
695811	60 x 30	White
B449335	96 x 18	White
B449334	72 x 18	White
B2241292	30 x 20	Charcoal
ROUND		
Model	Dia."	Color
256560	60	White



695749WN



695747RGY

INTERIOR® HEIGHT-ADJUSTABLE UTILITY TABLES

All-purpose table can be used in classrooms, offices, and training areas. High-pressure laminate top is stain- and scratch-resistant and the steel frame makes this table virtually indestructible. Legs have height-adjustable glides for uneven surfaces.

Model	W" x D"
695747	48 x 30
695749BK*	60 x 30
695751	72 x 30

* Add Color suffix to end of Model Number:
 GY (Gray), RGY (Rustic Gray),
 OK (Oak), WN (Walnut), BK (Black).



695430

INTERIOR® STANDING HEIGHT TABLES WITH POWER

Bar-height workstation tables combine durability with productivity. Designed for standing or sitting comfort with an all-around foot rest. Heavy-duty steel frame, super-strong bench top made of high-pressure laminate over MDF core. 8 power outlets. Gray or natural.

Model	L" x W"	Color
238329	96 x 30	Gray
238328	72 x 30	Gray
695431	72 x 36	Gray
695430	72 x 36	Natural
695433	96 x 36	Gray
695432	96 x 36	Natural

INTERIOR® LUNCHROOM TABLES

Breakrooms, lunchrooms, and eating areas are important gathering spaces in the workplace. These durable tables stand up to constant, everyday use. Solid particleboard laminate has vinyl T-mold banding that keeps food, moisture, and mold from penetrating the core. Wipe clean.

Model	L" x W"	Shape
695671CL	72 x 30	Rectangle
695673GY	42 x 42	Round
695674MH	36 x 36	Square
695805OK	42 x 42	Round
695848GY	72 x 36	Rectangle



695832GY

695829WN

INTERIOR® FOLDING WOOD TABLES

These all-purpose tables expand work space in the office and provide extra seating in schools, banquet halls, and more. Sturdy melamine surface repels moisture and resists hot and cold temperatures. Heavy-duty leg supports and gravity-locks ensure stability. Choose from Gray, Mahogany, and Walnut.

Model	W" x D"
695833	60 x 18
695834	72 x 18
695829	60 x 30
695832	60 x 60
695830	72 x 30
695831	96 x 30



INTERION® MOTORIZED ERGONOMIC HEIGHT-ADJUSTABLE DESKS

Sit and Stand Desks help to mitigate the health issues associated with prolonged sitting. The one-touch motorized height adjustability allows you to work comfortably at various heights. Four preset positions. Features a laminated top with a tube-steel frame on leveling feet.

Model	L" x W" x H"	Top Color	Frame Color
695781GY	72 x 30 x 28-46	Gray	Black
695780WHGY	60 x 30 x 28-46	White	Gray
695777LWN	60 x 60 x 23-48	Walnut	Black



INTERION® STEEL TEACHER'S DESKS

These durable desks have an easy-clean laminate top and sturdy construction. File drawers can accommodate both letter- and legal-sized files. Pull-out pencil drawer allows easy access for small accessories. Grommet holes enable easy cable wiring.

Model	W" x D"	Top Color
695631WN	48 x 30	Walnut
695632GY	60 x 30	Gray
695633MH	72 x 30	Mahogany

WE HAVE AN AMAZING ASSORTMENT OF FURNITURE & DÉCOR



INTERION® OPEN PLAN MODULAR DESKS

Modular system provides maximum versatility for your changing needs. This collection is suited for both individual and collaborative work. Surfaces are made of laminate and are pre-drilled for easy assembly. All hardware to connect desks is included.

Model	Description	W" x D" x H"	Color
695590	Office Desk	60 x 24 x 29	Charcoal
695606	Office Desk Return	48 x 24 x 29	Charcoal
695609	Pedestal with Cushion Seat	15 x 20 x 23 3/4	Red
695759	Low Credenza with Door	36 x 18.63 x 22	Black
695761	Low Credenza with Filing	36 x 18.63 x 22	Black



670073CH

INTERION® 60"W OFFICE DESK WITH FILE PEDESTAL

Interion® Office Desk features 1" thick scratch resistant laminate work surfaces on a charcoal finished steel frame. Desktop includes 2 3/16" diameter cable management grommet opening. Desk includes modesty panel and adjustable leveling glides. Steel File Cabinet features 2 box drawers and 1 file drawer that accepts letter or legal size filing. Pedestal includes ganged cylinder lock, recessed handles and adjustable leveling glides. 1 Year Limited Warranty.

Model	Type	W" x D"
670073CH	Cherry	60" x 24"
670073GY	Gray	60" x 24"
670078CH	Cherry	48" x 24"
670078GY	Gray	48" x 24"



SETUP FOR SUCCESS WITH MODULAR PARTITIONS & FURNITURE

Transform an empty cubicle into a furnished personal workspace with Global Industrial's collection of cubicle furniture. This selection of partition-friendly fixtures includes desks, shelving, cabinets, and more to create the organized work environment that every employee deserves.

All furniture features a minimalist design suitable for any office and is built to last with durable laminate tops and sturdy steel frames. Desk surfaces include a cable management hole. Add accessories like file cabinets, hanging shelves, and keyboard/mouse trays for easy organization and efficiency. Furniture is available in a variety of sizes.

CHOOSE YOUR PANEL OPTIONS

INTERION® MODULAR CUBICLES



PARTITION PANELS

A simple, unadorned partition designed to mesh with any décor and fit any budget.



DELUXE PANELS

A cherry-finished wood accent on top of each panel offers an upscale look at a very reasonable price.



PANELS WITH ELECTRIC

Get power where you need it with included UL-approved modular electric components and cable openings.



MOBILE PANELS

Four swivel casters make transport and rearrangement easy, creating instant privacy in any environment.



FREESTANDING PANELS

Include sturdy stabilizing legs, making them ideal for smaller spaces that require only one panel.



PANELS WITH WINDOW

Maintain a more open feel in your office area with a clear polycarbonate window at eye level.

CHOOSE YOUR FABRIC



Blue



Gray



Tan

QUICK & EASY 1-2-3 ASSEMBLY



Straight Connector



Corner 90° Connector



Wall Bracket Connector



Three Way Connector



Four Way Connector

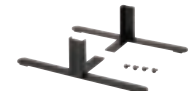

T-Leg (Pair)

CHOOSE YOUR DESK



DESKS
Modular desks function on their own or as a base for a more elaborate setup. Includes built-in modesty panel.



RETURNS
Smaller surfaces with a single leg that quickly connect onto full-sized desks to create angles or extensions.



CORNER DESKS
Fit perfectly where they're needed; ideal ergonomic workstations for an individual. Included built-in modesty panels and a rounded internal corner for comfort.

CHOOSE YOUR TOP



Cherry

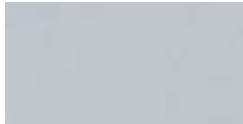

Gray

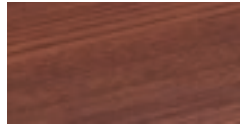

Mahogany



Walnut



Rustic Gray

CHOOSE YOUR ACCESSORIES



FILE CABINETS
Drawers are lockable and are ideal for storing files and other sensitive materials. Available in a variety of sizes and drawer quantities.



HANGING SHELVES
Keep office supplies, documents, and other essentials easily accessible. Shelves come in several lengths to fit various partition panels.



OVERHEAD CABINETS
Take full advantage of all available space by adding overhead cabinets to cubicle workspaces. Contents are kept secure with a locking flip-top door.



KEYBOARD & MOUSE TRAYS
Convenient, retractable space for a mouse and keyboard, freeing up desk space while still keeping them nearby and easily accessible.

FREE SPACE PLANNING HELP AVAILABLE

Let us come up with a customized design that's right for you.

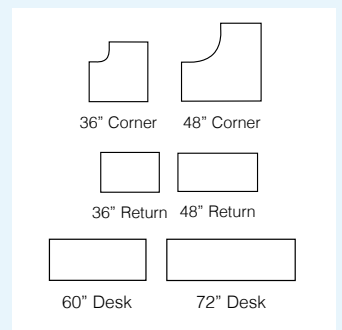
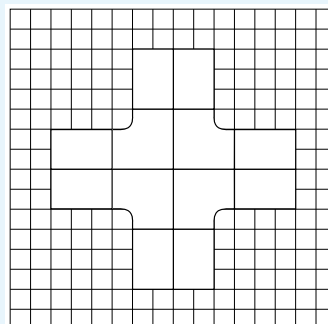



**INTERION®
RECEPTION TABLES**

Furnish your reception area with these coffee and end tables. Sturdy and stylish, they feature laminate tops with PVC edge-banding and powder coat steel legs. Choose from three colors.

Model	Style	W" x D" x H"	Top Color
695754BK	End Table	24 x 24 x 17	Black
695755BK	Coffee Table	48 x 24 x 16	Black
695754GY	End Table	24 x 24 x 17	Gray
695755GY	Coffee Table	48 x 24 x 16	Gray
695754MH	End Table	24 x 24 x 17	Mahogany
695755MH	Coffee Table	48 x 24 x 16	Mahogany



INTERION® RECEPTION SEATING

Make a good first impression with these comfortable padded guest chairs. Choose the style that complements your décor: vinyl, fabric or mesh-back styles with 18-gauge steel or wood frame. Meets BIFMA standards.

Model	Frame Color	Seat Material	Arm Type
250787BK	Black	Vinyl	Fixed
516129BK	Black	Fabric	Fixed
695625	Cherry	Fabric	Fixed
695627	Black	Fabric	Armless



INTERION® RECEPTION SEATING

Decorate your office & reception area with this line of contemporary synthetic leather seating. Perfect for heavy-use areas, each piece of furniture has been covered with an antimicrobial treatment that resists bacteria, mold, and mildew. Simply styled to complement modern or traditional décor, they have lightweight and durable frames and deep cushions for comfort. Choose from a sofa, loveseat, club chair, or bench.

Model	Type
695735-AM	Club Chair
695737-AM	Sofa
695736-AM	Love Seat

Model	Type	Arm Type
695731	Guest/Side Chair	Fixed
695732	Bench	Armless
695730	Guest/Side Chair	Armless



249190



239197



239115

MOBILE COMPUTER SAFETY CABINETS

- Heavy-duty gauge steel with powder coat finish
- Doors feature foam seals to keep out dust and debris
- Full access door in rear allows easy wiring and is louvered for ventilation
- Locking Compartments
- Ample working space
- Break resistant acrylic window
- Moving 5" industrial swivel casters (2 with brakes)



695429



273115



706669

Model	Description	Monitor Size	Monitor Type	Color
249190	Global Industrial™ Mobile Heavy-Duty LCD Computer Cabinet	27" Diagonal	LCD Monitors	Black (JBK or ABK), Blue (JBL or ABL) and Dark Gray (JGY or AGY)
239197	Global Industrial™ Mobile Heavy-Duty Computer Cabinet	27" Diagonal	LCD or CRT Monitors	Black (JBK or ABK), Blue (JBL or ABL) and Dark Gray (JGY or AGY)
239115	Global Industrial™ Mobile LCD Computer Cabinet	24" Diagonal	Flat Panel	Black (BK or BKA), Blue (BL or BLA) and Dark Gray (GY or GYA)
695429	Global Industrial™ Mobile Fold-Out Computer Cabinet	24" Diagonal	Flat Panel	Black (BK or BKA), Blue (BLA)
273115	Global Industrial™ Mobile LCD Console Computer Cabinet	21" Diagonal	LCD Monitors	Black (BK), Blue (BL) and Dark Gray (GY)
706669	Global Industrial™ Mobile Computer Cabinet	21" Diagonal	LCD or CRT Monitors	Black (BK), Blue (BL) and Dark Gray (GY)



239114



273114



695428

COUNTERTOP COMPUTER SECURITY CABINETS

- Designed to hold up to 24" diagonal LCD/LED or CRT monitors
- Heavy-duty gauge steel with powder coat finish
- Locking compartments
- Available in up to 4 colors: Black (BK), Blue (BL), Dark Gray (DG), Gray (GY)

Model	Description
239114	LCD Counter Top Security Computer Cabinet
273114	LCD Console Counter Top Security Computer Cabinet
695428	Counter Top Fold-Out Computer Security Cabinet
607294	Counter Top CRT Security Computer Cabinet

MOBILE COMPUTER CABINET

- Heavy-duty gauge steel with powder coat finish
- Locking compartment
- CPU shelf adjusts to accommodate either tower or desktop styles
- Rear cabinet access holes are provided
- Moves on 5" industrial swivel casters (2 with brakes)
- Available in 3 colors: Black (BK) Gray (GY), Assembled: Black (BKA), Blue (BLA)



694561



436996BK



436998BK

MOBILE POWERED CARTS

These carts are ideal for warehouses, manufacturing facilities, shipping & receiving, and industrial environments where employees constantly move between areas. Choose between 40AH or 100AH rechargeable batteries, configured as either a laptop cart or an exclusive Orbit cart. Optional accessories available separately.

Model	Description
436996BK	AV Cart with 40AH Battery
436997BK	Cart with 100AH Battery
436998BK	Orbit Cart with 40AH Battery
436999BK	Orbit Cart with 100AH Battery
436993BK	Scanner Holder
670192	Single Monitor Desk Mount
436994BK	Keyboard Tray for Laptop Cart
436995BK	Slide-Out Printer Tray for Laptop Cart
706543BK	Locking Keyboard Drawer for Orbit Cart



239134BG

81" H ORBIT COMPUTER WORKSTATION WITH VESA MOUNT

Workstation includes a 5" x 5" steel center post, flat panel screen mount and CPU holder. Steel surfaces have a powder coat finish. Post includes 3 cable management openings at 15", 42 1/2" and 70"H. Post base measures 17 1/2" x 17 1/2". 36"W x 20"D Work surface has a 1" thick wooden core with plastic laminate finish. Accommodates sitting or standing. VESA mount holds any flat panel monitor from 10-30", monitor tilts up 15° and down 5° Locks in place with a thumb screw. The CPU/power supply holder holds items up to 9"W securely. Includes non-skid cushions to prevent marring.

Model	Finish
239134BG	Beige
239134BK	Black



239134BG

81" H FLOOR MOUNT ORBIT COMPUTER KIOSK WITH VESA MOUNTS

Unit includes 4 work surfaces, 2 CPU holders, 81"H center post and 2 VESA universal flat panel screen mounts. Steel surfaces have a powder coat finish. Easy assembly. 4 steel work surfaces install around the center post to accommodate 4 users at once. Each surface is made of 14 gauge steel and measures 41 1/4"W x 19 1/4"D. Can be mounted at 30" or 40"H. The CPU/power supply holders holds items up to 9"W securely and include non-skid cushions. The 5" x 5" steel center post bolts to the floor for stability (hardware not included). Post includes 3 cable management openings at 15", 42 1/2" and 70"H. Post base measures 17 1/2" x 17 1/2".

Model	Finish
239193BK	Black
239134BG	Beige

670052



670051



LAPTOP, CHROMEBOOK, & TABLET CHARGING CARTS

Carts keep mobile devices charged and safely stored, with a 3-point locking system. All-steel construction with ventilated doors and sides and a nonskid top. Rear door gives easy access to electrical connections. Choose the slot size that best accommodates your mobile devices.

987878



Model	Type	Device Storage
985748	Mobile	12 Chromebooks & Tablets
670051	Cabinet	16 Chromebooks & Tablets
251761	Mobile	24 Chromebooks & Tablets
670052	Mobile	32 Chromebooks & Tablets
987877	Mobile	36 iPads & Tablets
987878	Mobile	75 iPads & Tablets



277441PY

INTERION® STEEL BOOKCASE

This bookcase offers the ultimate in flexibility and value. Built to last, in heavy-gauge steel with double-wall construction. Shelves adjust easily in 1¼" increments without removing or adjusting other shelves. Five dividers included.

252471PY



252471BK

252469BK

INTERION® PREMIUM LATERAL FILES

Steel cabinets are designed for side-to-side lateral filing, or add the included front-to-back bars to convert to 2 rows of front-to-back filing. Ball-bearing slides allow for full drawer extension. Accepts letter or legal size files. Choose from various sizes and colors.

SECURITY SOLUTIONS THAT STAND OUT FROM THE CROWD.



298703

INTERION® BLUEPRINT PIVOT MOBILE RACK

Vertical file rack provides space-saving storage systems for blueprints, drawings, and more. An exclusive suspension system has 12 included pivoting clamps for easy viewing. Each binder holds up to 100 sheets. Anodized aluminum with enamel finish.



506826PY

INTERION® BLUEPRINT FLAT FILE CABINET

Designed for large papers and drawings, flat file cabinets have hinged paper depressors in each drawer to keep documents flat and curl-free. Easy-glide ball bearing drawer runners and bumpers provide smooth opening and closing.



PET WASTE STATION
(PAGE 119)

SEATING
(PAGE 119)

PLAYGROUND EQUIPMENT
Find the complete selection at globalindustrial.com

PICNIC TABLES
(PAGE 117-118)

DRINKING FOUNTAINS
(PAGE 149)

TRASH CONTAINERS
(PAGE 80)

PEDESTAL GRILLS
(PAGE 118)

10 WAYS TO CREATE THE PERFECT OUTDOOR ESCAPE

In the heat of the moment, you want to make an impression. Your outdoor space is no exception. It should be clean, inviting, and make your guests want to stay for a while. Whether you're looking to make quick upgrades to dining areas, or increase comfort, we have everything you need to design the ideal outdoor escape.

- 1** Decide where improvements and upgrades can be made.
- 2** Understand the common temperature of the area.
- 3** Consider placing canopies around existing outdoor furniture (page 99).
- 4** Install cooling fans in areas where large crowds congregate (page 69).
- 5** Ensure all water fountains and hydration stations are working (page 149).
- 6** Purchase new trash cans, in one color, for a quick upgrade to your space (page 80).
- 7** Place barriers and safety guards where crowd control can become an issue (page 136-137).
- 8** Provide additional seating and picnic tables that can stand up to the weather (page 117-118).
- 9** Place bicycle racks and metal equipment in the shade (page 102).
- 10** Invest in furniture covers to protect chairs and dining areas overnight.

Surrounding your commercial office, hotel, or business with the right outdoor equipment, seating, and amenities is essential to your success—and that's where we come in.



277152

THERMOPLASTIC- COATED METAL RECTANGLE PICNIC TABLES

- Thermoplastic coating on benches and tabletop
- Resists fading, stays cooler in direct sun
- Galvanized steel frame with corrosion-resistant finish
- Available in assorted colors, sizes, patterns
- Add Color Suffix to Model When Ordering: BK = Black, BL = Blue, GN = Green

Model	Description	Size"
695485	Expanded Metal	48 x 30
277152	Expanded Metal	72 x 30
277153	Expanded Metal	96 x 30
694553	Perforated Metal	72 x 30
694555	Perforated Metal	96 x 30



277150GN

THERMOPLASTIC- COATED METAL ROUND PICNIC TABLES

- Thermoplastic coating on benches and tabletop
- Resists fading, stays cooler in direct sun
- Galvanized steel frame with corrosion-resistant finish
- Available in assorted colors, sizes, patterns
- Add Color Suffix to Model When Ordering: BK = Black, BL = Blue, GN = Green

Model	Description	Size"
277150	Expanded Metal	46
262078	Perforated Metal	46
277590	6 Seats, Expanded Metal	46



694551

THERMOPLASTIC- COATED METAL SQUARE PICNIC TABLES

- Thermoplastic coating on benches and tabletop
- Resists fading, stays cooler in direct sun
- Galvanized steel frame with corrosion-resistant finish
- Available in assorted colors, sizes, patterns
- Add Color Suffix to Model When Ordering: BK = Black, BL = Blue, GN = Green

Model	Description	Size"
695501	Expanded Metal	36
277151	Expanded Metal	46
694551	Perforated Metal	46
695965	With Backrests, Expanded Metal	46



436982

THERMOPLASTIC- COATED METAL OCTAGONAL PICNIC TABLE

- Thermoplastic coating on benches and tabletop
- Resists fading, stays cooler in direct sun
- Galvanized steel frame with corrosion-resistant finish
- Available in assorted colors
- Add Color Suffix to Model When Ordering: BK = Black, BL = Blue, GN = Green

Model	Description	Size"
436982	Expanded Metal	46

THERMOPLASTIC- COATED METAL ADA PICNIC TABLES

- Thermoplastic coating on benches and tabletop
- Resists fading, stays cooler in direct sun
- Galvanized steel frame with corrosion-resistant finish
- ADA-compliant
- Available in assorted colors
- Add Color Suffix to Model When Ordering: BK = Black, BL = Blue, GN = Green

Model	Mount Type	Shape	Table Size"	Overall W" x L"
695290	Surface	Round	46	84 x 65
695291	Surface	Square	46	81 x 63
695289	Surface	Rectangle	96 x 30	96 x 60
695294	In-Ground	Round	46	84 x 65
695295	In-Ground	Square	46	81 x 63



436990TN



695971

EXCLUSIVE BRANDS

RESIN OUTDOOR DINING SETS

- Includes table and 4 stacking chairs
- Umbrella hole and cap in center of tabletop
- Durable resin-slat tabletop and seats
- Rust-resistant powder coat steel frame

Model	Description	Size"
436990TN	Square	40
436991TN	Rectangle	70

MESH CAFE DINING SETS

- Commercial-grade and powder-coated steel construction.
- Made of rust and corrosion-resistant materials for lasting outdoor use.
- Reliably designed for ultra-low maintenance.
- Center 2" umbrella hole.
- Chair Weight Capacity: 250 lbs.
- Chair Seat Dimensions: 17³/₄"W x 18"D x 16³/₄"H
- 3 Year Limited Warranty.

Model	Description	Size"
695972	Round	36
695971	Round	48
695974	Square	36
695973	Square	48



348124



244309

EXCLUSIVE BRANDS

5-PIECE OUTDOOR DINING TABLE AND CHAIR SETS

- Thermoplastic coating resists fading, mold, and vandalism
- High-gloss surface stays cool to the touch
- Long-lasting and durable steel construction

Model	Description	Size"
348119BK	Square	29
348120BK	Square	36
348121BK	Bar Height, Square	42
348122BK	Round	29
348123BK	Round	36
348124BK	Bar Height, Round	42

EXCLUSIVE BRANDS

TEAKWOOD OUTDOOR DINING SETS

- Includes 4 sling-style arm chairs
- Weather-resistant square teakwood table top
- Lightweight and durable aluminum frame and legs
- Leveling feet on table legs improve stability

Model	Description	Size"
244309	Square	27 ¹ / ₂
244310	Round	27 ¹ / ₂

SQUARE 16' SHADESAILS

- Provides shade to protect against intense sun
- UV-stabilized fabric provides a long service life
- Breathable fabric enables airflow to vent heat

Model	Color
B431231	Sand
B431235	Sea



THERMOPLASTIC- COATED METAL BENCHES

- Thermoplastic coating on seats and backs
- Resists fading, stays cooler in direct sun
- Galvanized steel frame with corrosion-resistant finish
- Available in assorted colors, sizes, patterns
- Available in portable, surface and in-ground mounting
- Add Color Suffix to Model when ordering BK = Black, BL = Blue, GN = Green, GY = Gray, RD = Red

Model	Description	Size"
695743	Backrest, Expanded Metal	48
277154	Backrest, Expanded Metal	72
277155	Backrest, Expanded Metal	96
695744	Backrest, Perforated Metal	48
694557	Backrest, Perforated Metal	72
262077	Backrest, Perforated Metal	96

Model	Description	Size"
695741	Flat, Expanded Metal	48
277156	Flat, Expanded Metal	72
277157	Flat, Expanded Metal	96
695742	Flat, Perforated Metal	48
262075	Flat, Perforated Metal	72
262076	Flat, Perforated Metal	96



RECYCLED PARK BENCHES

- Recycled wood and plastic composite slats
- Powder-coated wrought iron legs
- Available in 3 colors
- Portable and/or surface mount

Model	Size'	Color
240125	4	Green
240125BK	4	Black
240125TN	4	Tan
240125GY	4	Gray
240126	6	Green
240126BK	6	Black
240126TN	6	Tan
240126GY	6	Gray

STEEL SLAT BENCHES

- Heavy-duty construction for high-traffic areas
- UV-stabilized, rust-resistant powder coat finish
- Available in 3 colors
- With or without backrest
- Portable and/or surface mount
- Add Color Suffix to Model when ordering BK = Black, BL = Blue, GN = Green No Suffix = Green



Model	Description	Size'
694853	With Backrest, Vertical Steel	4
694854	With Backrest, Vertical Steel	6
694855	With Backrest, Vertical Steel	8
262112	Backless, Vertical Steel	4
262113	Backless, Vertical Steel	6
262114	Backless, Vertical Steel	8

Model	Description	Size'
436974	With Backrest, Horizontal Steel	4
436975	With Backrest, Horizontal Steel	6
436976	With Backrest, Horizontal Steel	8



OUTDOOR ALL-ALUMINUM PARK BENCHES

- All-aluminum Park Benches are ideal for train stations, park facilities, shopping areas, and other areas where spaces for public seating are needed
- Rustproof aluminum construction
- Powder-coated frame, seat and backrest resist rust and corrosion
- Stylish horizontal slatted design
- Overall Dimensions: 73"L x 22-3/4"W x 30-3/4"H
- Seat Dimensions: 68"L x 17"W x 16-1/2"H
- Weight Capacity: 1100 lbs
- Flexible surface mount allows quick relocation

Model	Description
436978BK	6' Aluminum Park Bench w/ Backrest, Black
436977BK	6' Aluminum Park Bench, Black

SAFETY & SECURITY

120-139

EXCLUSIVE BRANDS

VISITOR SAFETY GLASSES

Made of polycarbonate for durability and corrosion-resistance, these safety glasses provide eye protection for job sites, warehouses, plants, and more. Meets ANSI Z87.1. Sold in packages of 10. Available with anti-scratch hard coating for added protection.



708121HC

Model	Coating
708121HC	Hard Coat
708400	None

EXCLUSIVE BRANDS



708402SM



708402CL

SPORT HALF-FRAME SAFETY GLASSES

Lightweight wraparound sport half-frame glasses feature anti-fog coating and soft nose pieces for optimal comfort during prolonged wear. Meets ANSI Z87.1 standards.

EXCLUSIVE BRANDS

LENS CLEANING WIPES

- Ideal for cleaning glass or polycarbonate lenses
- Anti-fog and anti-static for non-abrasive cleaning
- Disposable, convenient wipes offer silicone-free cleaning
- 100 Wipes/Package



708584

EAR PLUGS

Reusable, washable ear plugs have an air bubble in the tip for cushioned comfort. 100% PVC-free. Noise decibel rating of 27 dB provides protection in most noisy environments. Easy-grip end is easy to insert and remove. Case included.



B311097

Model	Style
B311097	Uncorded
B311098	Corded

EXCLUSIVE BRANDS

WRAPAROUND SAFETY GLASSES

Polycarbonate wraparound safety glasses are the ideal choice for standard eye protection. Wraparound design provides more protection with an unobstructed view. Meets ANSI Z87.1.



708119CL

Model	Lens Color
708119CL	Clear
708119SM	Smoke

Also available in anti-fog by adding suffix AF to the model number.

EXCLUSIVE BRANDS

SAFETY GOGGLES

- Polycarbonate lens
- Elastic Strap
- Meets ANSI Z87.1+



708583

Model	Description	Vent
708582	Impact Resistant	Direct
708583	Splash Resistant	Indirect

Also available in anti-fog by adding suffix AF to the model number.

EXCLUSIVE BRANDS

DISPOSABLE EARPLUGS

Global Industrial™ low-pressure foam disposable earplugs conform to your ear canal for superior comfort. The dispenser packs allow convenient access in high-traffic areas; disposable design improves user hygiene. Choose from two shapes; Tapered and Contoured. Noise decibel level: 32dB.



708377



708376

Model	Style	Shape
708375	Uncorded	Tapered
708376	Corded	Tapered
708377	Uncorded	Contoured
708378	Corded	Contoured



HIGH-PERFORMANCE HEADGEAR FACE SHIELDS

Deeper crown protector extends coverage without increasing weight. Highly heat-resistant material. Fits easily over required eyewear or respirators. Windows are constructed from high impact-resistant propionate. Meets ANSI Z87.1+ and CSA Z94.3 standards.

B312561 HEADGEAR



B312745 WINDOW

Model	Description
B312561	F400, 4" Crown Headgear
B312564	F500, 7" Crown Headgear
B312745	8"W x 11¼"H Propionate Window, Clear

SPARKPLUGS® PLUGSTATION® EARPLUG DISPENSERS

Dispenser easily mounts to any wall, ensuring hearing protection is readily available.

Ear plugs feature extra-soft, low-pressure foam for exceptional comfort. Tapered shape allows for easy insertion and removal. Plugs are NRR 33dB tested, CSA Class A1.

Model	Pkg. Qty.
B308767	250 Pairs
B311542	500 Pairs



B308767



VERISHIELD™ PASSIVE EARMUFFS

Earmuffs provide comfortable noise protection. Made of molded ABS plastic with an internal baffle design for lighter weight. Wide cup opening and large dimension range fits most head sizes. Oil-resistant cup surface withstands oily, heavy-work environments & frequent cleaning.



B2319545

Model	Color	NRR
B2319545	Black	24
B2319544	Black	26
B2319540	Black	30
B2319541	Hi-Viz Yellow	30

B2279031



B2279027



MSA V-GARD HARD HATS

V-Gard Series Hard Hats feature an HDPE shell that provides superior impact protection. Fas-Trac III® suspension and self-adjusting crown straps provide a truly customized and comfortable fit. ANSI Type 1 Hard Hat, Class E.

Model	Type	Color
B2279027	Full Brim	White
B2279031	Front Brim	Yellow
B2278966	Front Brim	Blue
B2278874	Front Brim	Gray
B2278965	Front Brim	Green



PARTICULATE RESPIRATORS

N95 particulate respirators provide protection against dust and non-oil based particles. Lightweight construction and adjustable nose clip with cushioned seal, provides added comfort during wear. Exhalation valve reduces heat build-up and moisture for more comfortable wear. Meets NIOSH 42 CFR 84 N95.



651481



651475

Model	Series	Exhalation Valve	Package Qty.
651481	8511	Y	10
651475	8210	N	20

7000-SERIES REUSABLE RESPIRATORS

Made of an advanced silicone material for a softer feel and a unique adjustment design that helps reduce the tension and pressure points for unsurpassed comfort. The exhalation valve design helps make breathing easier and helps reduce heat and moisture build-up.



795246

Model	3M Model	Mask Size
795244	7501	Small
795245	7502	Medium
795246	7503	Large

Model	3M Model	Cartridge Description
795251	60923	Organic Vapor/Acid Gas/P100
795250	60921	Organic Vapor/P100
795252	60926	Multi-Gas/Vapor/P100
795247	6001	Organic Vapor
795248	6003	Organic Vapor/Acid Gas
795249	6006	Multi Gas/Vapor



WHEN SAFETY IS IMPORTANT, MAKE SURE EVERYTHING IS ALL HONEYWELL AND GOOD.

Honeywell

**PURE FLOW 1000®
EMERGENCY EYEWASH STATION,
7-GALLON CAPACITY**

This device uses sealed-fluid cartridges to eliminate costly plumbing needs. Cartridges include a nozzle and hose to ensure delivery of Eyesaline™ solution.

Model	Description
237680	Pure Flow 1000® Emergency Eyewash Station, 7 Gallon Capacity
237681	Pure Flow Cartridge Refills, 2/Pack

237680



Pull Handle Down to Begin Saline Flow



Eye-View Station

NORTH® 5400 SERIES LOW-MAINTENANCE FULL FACEPIECE RESPIRATOR

Lightweight design offers comfort that ensures worker acceptance. The facepiece seal is made from a soft, pliable elastomer with high chemical resistance. Filters available separately.

Model	Description
B313316	North® 5400 Series Low Maintenance Full Facepiece Respirators, 54001
B312128	North® Combination Gas and Vapor Cartridges, 75SCP100L, 2/Pk
B312127	North® Combination Gas and Vapor Cartridges, 7584P100, 2/Pk
B2453160	Honeywell North 7583P100L Organic Vapor/Acid Gas Cartridge & P100 Filter, 2/Pk



**SHOP OUR FULL LINE
OF HONEYWELL
PRODUCTS**

B2255100



MILLER® SCORPION™ 9'L FALL LIMITER, STEEL TWIST-LOCK CARABINER

The lightweight, compact design provides greater mobility, safety, and versatility compared to shock-absorbing lanyards. It requires less fall clearance and prevents tripping hazards, and a visual load indicator shows when the unit must be replaced. Use as a personal fall limiter or as a traditional retractable lifeline.

MILLER MANYARD® II SHOCK-ABSORBING LANYARD

- Stretchable, shock-absorbing lanyard
- Contracts 6' to 4' to reduce tripping, snagging, or dragging hazards
- Working load of 310 lbs.
- Warning flag to indicate that it has arrested a fall

B313421



MILLER® TITAN NON-STRETCH HARNESS

- Sliding back D-ring
- Universal fit with tongue-buckle legs, mating-buckle chest and shoulder straps; sub-pelvic strap
- Integrated, oversized pull-free lanyard rings
- Bright webbing color is easily visible
- Meets all OSHA, ANSI, & CSA standards
- Available in L/XL

436720



TURBOLITE™ PERSONAL FALL LIMITERS

- Requires less fall clearance than traditional shock-absorbing lanyards
- High-impact nylon housing and abrasion-resistant webbing
- Attaches directly to harness back D-ring
- Rated up to a 400 lb. worker
- Meets OSHA:ANSI Z359.14 Class A & B and CSA Z259.2.2



B313426

Model	L'	Unit Connector	End Connector
B313426	6	Steel Carabiner	Steel Snap Hook
B313396	6	Aluminum Carabiner	Aluminum Snap Hook
B2255125	6	Steel Carabiner	Steel Rebar Hook
B2255111	6	Aluminum Carabiner	Aluminum Rebar Snap
B2255124	9	Steel Carabiner	Steel Snap Hook

CONTRACTOR 1D HARNESS & 6' LANYARD COMBO

This combination set provides a starting point for building a complete personal fall arrest system. Includes universal fit harness and 6' shock-absorbing lanyard. Harness features back D-ring, mating legs and chest buckle. Lanyard features single leg with 2 snap hooks. Meets applicable OSHA and ANSI regulations.



761317



MILLER® STRETCHABLE HARNESS

Features stretch webbing that provides greater comfort, safety, and mobility. Pull-free lanyard rings allow the user to attach lanyard when not in use. Belt loops accommodate a tool belt. Universal size. Meets or exceeds all OSHA, ANSI, and CSA specifications.



B312994



PROTECTA® FIRST™ HARNESSES

Protecta Harnesses are made from strong, durable 100% polyester and constructed to last through your toughest job. Universal one-size fit. Comes standard with back D-rings for fall arrest. Available with either tongue buckle legs or pass-thru buckle legs. Meets OSHA 1926 and ANSI Z359.1 standards.



795490

Model	Description
795490	Pass-thru buckle
795491	Pass-thru buckle w/side D-ring
795492	Tongue buckle
795493	Tongue buckle w/side D-ring



MILLER® FULL-BODY HARNESS

- Designed to meet common fall protection needs
- Provides fundamental fall protection at an exceptional value
- 5 points of adjustment for a custom fit
- Lightweight and comfortable



708495

PRO™ PACK SHOCK-ABSORBING LANYARD

Durable webbing and plated alloy steel hardware for strength and corrosion-resistance. Energy-absorbing design limits fall arrest forces. User-friendly self-locking snap hooks at each end. High-quality compliance at an affordable price. 6' lanyard is compact and lightweight at 2.3 lbs. Meets OSHA 1910.66, OSHA 1926.502, and ANSI A10.32.



436801



I-BEAM TROLLEY

I-Beam Trolley provides a fast and safe tie-off point for personal fall protection systems. Installs onto I-beam flanges from 3" - 8" in width and up to 11/16" thick. Ideal for use with self-retracting lifelines. Features easy-to-use dual-adjustment dials. Meets OSHA and ANSI Z359 standards.



B312014



AUTO-LOCKING CARABINER

- Spring-loaded keepers with 1" gate opening
- Use as anchorage connectors
- Rated for 400 lbs. maximum capacity
- Meets or exceeds OSHA 1926.502, ANSI Z359-2007, and CSA Z259.12 requirements



B861869

GET A GRIP ON SAFETY

According to the US Bureau of Labor Statistics, hands are the second most frequently injured body part.

How to choose the right glove: Observe the physical environment where the gloves will be worn. Will the user's hands get hot and sweaty? Does the person need a thin glove to feel and handle parts? Do they use a touch screen? Will the hand get wet? If so, what kind of liquid: water, oil, gas, acid, etc.? Will they need to remove and put on the gloves to perform actions?

Liner:

Base material of the glove that provides overall strength.

Nylon Knit: Lightweight, durable fabric. Stretchy, conforms to hand.

Polyester: Durable fabric, resistant to UV rays. Slightly stretchy.

Poly/Cotton: Blended material with added elasticity.



Grip:

Imprinted patterns or parts of coating material to enhance the functionality of glove in their intended environments.

Smooth: Excellent dry grip. Liquids will not absorb into coating to keep hands dry.

Foam/Micro Foam: Channels liquids away to allow better handling in wet and dry conditions.

Crinkle: Provides added protection against cuts and punctures while channeling liquid for better handling in wet and dirty conditions.

Sandy: Added abrasion resistance and better handling in wet environments.

Coatings:

Materials that determine the purpose and application of a glove.

Nitrile: Excellent dry grip, good wet grip.

Latex: Good dry and wet grip.

Polyurethane: Good dry grip. Excellent tactile sensitivity

Gauge:

Number of stitches per square inch. Higher gauge gloves are thinner and provide better dexterity.



	Micro-Foam Nitrile-Coated	Foam Nitrile-Coated	Smooth Nitrile-Coated	Ultra-Grip Sandy Foam Nitrile-Coated	Ultra-Grip Foam Latex-Coated	Double Foam Latex-Coated	Smooth PU-Coated	Crinkle Latex-Coated	Crinkle Latex Poly-Knit Coated
Model	708122*	708344*	708346*	708345*	708349*	708353*	708350*	708347*	708348*
Liner	Nylon Knit	Nylon Knit	Nylon Knit	Nylon Knit	Poly/Cotton	Nylon Knit	Nylon Knit	Polyester	Polyester
Gauge	15	13	13	13	10	13	13	13	10
Grip	Micro-Foam	Foam	Smooth	Sandy Foam	Foam	Double Foam	Smooth	Crinkle	Crinkle
Coating	Nitrile	Nitrile	Nitrile	Nitrile	Latex	Latex	Polyurethane	Latex	Latex
Size	M-L	SM-XL	SM-XL	SM-XL	SM-XL	SM-XL	SM-XL	SM-XL	SM-XL



	Crinkle Latex-Coated Hi-Viz	Crinkle Latex Poly-Knit Coated Hi-Viz
Model	708603	708604
Liner	Polyester	Nylon
Gauge	13	13
Grip	Crinkle	Crinkle
Coating	Rubber/Latex	Polyurethane
Size	SM-XL	SM-XL

* For specific product sizing, please add the following suffixes to the model number; Small (SM), Medium (M), Large (L) and X-Large (XL).

SHOP OUR FULL LINE OF GLOVES FROM BRANDS INCLUDING PIP, MCR, ANSELL, HONEYWELL, AND MORE



708191

DISPOSABLE PROTECTIVE CLOTHING

Disposable coveralls protect against various contaminants. Polypropylene protects against nonhazardous dry particles. Microporous fabric protects against non-hazardous particles, light splashes, and aerosols. Zip front for easy user access and removal. White. Add size suffix: Small (S), Medium (M), Large (L), X-Large (XL), 2X-Large (XXL), 3X-Large(XXXL). Case Qty 25.

Base Model	Fabric	Wrist/Ankles	Size	Hood	Boots
708190	Microporous	Elastic	M-3XL	✓	-
708189	Microporous	Elastic	M-3XL	-	-
708191	Microporous	Elastic	M-3XL	✓	✓
708188	Microporous	Open	M-3XL	-	-
708187	Polypropylene	Elastic	M-3XL	✓	✓
708186	Polypropylene	Elastic	S-3XL	-	-
708185	Polypropylene	Open	M-3XL	-	-



708309

DISPOSABLE LAB COATS

These disposable lab coats provide protection against dry particulates such as dust, dirt, and debris. Polypropylene construction provides lasting strength and dependability. Snap front, elastic wrists, and collar secure the lab coat. 25/ Case. Add size suffix to model number: Medium (M), Large (L), X-Large (XL), 2X-Large (XXL).

Model	Type	Sizes
708208	Elastic Wrists & Polypropylene Collar	M-2XL
708309	Knit Wrists & Collar	M-2XL



708192A

BOUFFANT CAPS & HAIRNETS

These hairnets contain and prevent loose hair contamination for food service applications including restaurants, cafeterias, commercial kitchens, and more. Caps are constructed from polypropylene and hairnets are constructed from nylon honeycomb. White.

Model	Type	Dia.,"
708192A	Bouffant Cap	21
708192B	Bouffant Cap	24
708192C	Bouffant Cap	28
708193A	Hairnet	20
708193B	Hairnet	24



708507

DISPOSABLE EAR LOOP FACE MASKS

Face masks provide nose and mouth protection against airborne particulates including dust, debris, pollen, and more. The lightweight polypropylene construction is designed for user comfort without annoying pressure points. Flexible nose piece, knitted ear loops.

Model	Description
708507	Adult, 50/Box
708527	Adult, Individually Packed 50/Box

695304



708149

NON-ANSI HI-VISIBILITY SAFETY VESTS

Available in bright orange or pink, the vest is made of breathable polyester mesh with elastic hook-and-loop closure straps for a universal, secure fit. Reflective strips on front and back ensure high visibility in both dark and light conditions.

Model	Color
695304	Orange
708149	Pink

695305



Built-In Storage Pockets

ANSI CLASS II HI-VISIBILITY VESTS

Made of durable, long-lasting polyester, these vibrant lime-colored vests ensure visibility day and night. Continuous 2" reflective strips add visibility on job sites and in poorer weather conditions. Solid vests feature hook-and-loop closure. Mesh vests feature three storage pockets and zipper closure.

Model	Size	Closure Type	Color
695307	S/M	Hook & Loop	Lime
695308	L/XL	Hook & Loop	Lime
695309	2XL/3XL	Hook & Loop	Lime
695305	L	Zipper	Lime
695306	XL	Zipper	Lime

B1727708



HI-VISIBILITY CLASS 3 WATERPROOF QUILT-LINED BOMBER JACKET

Made with 100% waterproof PU-coated shells, sealed seams, and a concealed hood, they feature 4-3/4-oz. polyfill insulation with a polyester quilted lining, zippered closure and snap storm flap, and an assortment of pockets. ANSI/ISEA 107-2010 Class 3 compliant.

Model	Color
B1727708	Lime
B1834520	Orange

B1834338



CLASS 3 PREMIUM HOODED RAIN COAT

The combination of waterproof PU coated 150D Oxford material, sealed seams, and a snap-front zipper protects workers in harsh environments, while the hi-vis yellow color and 2" reflective silver tape keeps them safe. ANSI/ISEA 107-2010 Class 3 certification. Matching pants available separately.

Model	Size
B1834339	S/M
B1834338	L/XL
B1834577	2XL/3XL

B2939664



ONYX SURVEYOR'S SAFETY VEST

Comfortable to wear with plenty of pockets & pouches for tools and instruments. Ripstop polyester, mesh back & padded neck. Reflective tape with contrasting reflective trim.

Model	Size
B2939676	M
B2939664	L
B2939677	XL
B2939650	2XL

B1961853

B1961876



CLASS 2 HEAVY-DUTY SAFETY VEST

These Class 2 vests are ideal for airport baggage handlers & ground crew, forestry workers, parking attendants, and utility workers. ANSI/ ISEA 107-2010 Class 2 compliant. Size: XL.

Model	Color
B1961876	Lime
B1961853	Orange

B1834522



MULTI-PURPOSE CLASS 2 MESH SAFETY VEST

Designed for comfort & safety, the vest is made polyester mesh with a convenient hook & loop closure and reflective silver tape details. Pen/ instrument organization chest pocket and inside pocket. ANSI/ISEA 107-2010 certification.

Model	Size
B1834339	M
B1834338	L
B1834577	XL
B1834577	2XL

B2939615



ENHANCED-VISIBILITY MULTI-COLOR VEST

Made of polyester mesh with a zipper closure, this vest has 2" silver reflective tape with a contrasting trim to maximize visibility in hot weather or over regular outerwear. It has a variety of pockets and a mic tab on the shoulder. NON-ANSI certified.

Model	Color
B2939619	Red
B2939708	Black
B2939723	Purple

ANSI-COMPLIANT FAKS ARE ALL UP TO DATE WITH THE NEW ANSI 2021 STANDARDS

EXCLUSIVE BRANDS

EXCLUSIVE BRANDS

761288A



ANSI-COMPLIANT FIRST AID KITS

Global Industrial™ Class A First Aid Kits provide a quick and handy storage solution for minor accident and medical emergency supplies. Storage cases can be wall mounted or portable with an easy carry handle. Available in plastic or metal cases. Refill Kit contains necessary components for 25 or 50 persons. Meets ANSI Z308.1-2021 standard.

Model	Case	People Served
761287A	Plastic	10
761288A	Plastic	25
761289A	Plastic	50
761292A	Metal	25
761290A	Metal	50
761285A	Refill Kit	25-50



761297A

ANSI-COMPLIANT FIRST AID CABINETS

Steel cabinets are adequately stocked for minor accidents, ailments, and injuries. Each Class B kit includes supplies to treat minor cuts, eye irritation, personal discomfort, burns, and trauma. Includes carry handle; can be wall-mounted. Meets ANSI Z308.1-2021 standard.

Model	Description	# of People Served	W" x D" x H"
761295A	2-Shelf	50-75	10½ x 4¾ x 15¼
761296A	3-Shelf	75-100	13½ x 5½ x 16
761297A	4-Shelf	100-150	15 x 5¾ x 22
761294A	Refill Kit	Up to 75	-

EXCLUSIVE BRANDS



B892445

BLOODBORNE PATHOGEN KIT

Designed for the safe and sanitary removal of spilled bodily fluids, blood, and other potentially infectious substances in the workplace. Helps comply with OSHA Bloodborne Pathogen Rule 29 CFP 1910.1030.

EXCLUSIVE BRANDS

761286



FIRST AID BURN KIT

Global Industrial™ burn kits provide a quick & handy solution for minor accidents and medical emergencies. These first aid kits are held in a reusable plastic case for secure, organized storage. This 14-piece burn kit includes the basic necessities for burn care.

B305565

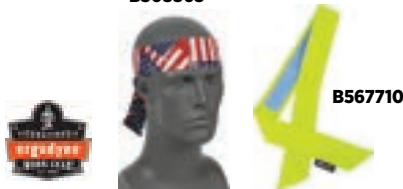

B567710

EVAPORATIVE COOLING BANDANAS

- Activated polymers bring cooling power where you need it most
- Activate by soaking in water for 2-5 minutes
- Remains hydrated for up to 4 hours
- Reusable, just soak in water to re-activate
- 6 colors; 2 with built-in cooling towel

Model	Type	Color
B305669	Cooling Bandana	Navy Western
B305668	Cooling Bandana	Red Western
B305689	Cooling Bandana	Solid Blue
B305565	Cooling Bandana	Stars/Stripes
B567710	Cooling Bandana w/ Built-In Towel	Lime
B567711	Cooling Bandana w/ Built-In Towel	Blue

B542746



WATERPROOF WINTER GLOVES

The perfect all-purpose winter glove: waterproof, windproof, and lined with soft fleece 3M Thinsulate™ insulation. Gauntlet cuff with adjustable closure adds extra warmth. Durable, form-fit outer shell and non-slip palms help maintain dexterity. Add size suffix: Small (S), Medium (M), Large (L), X-Large (XL), 2X-Large (XXL).



B2396218

B306073

FLEECE NECK GAITER AND BALACLAVA

Fleece neck gaiters and balaclavas provide warm, no-bulk protection from the most demanding winter conditions. Wear alone or as a layering option with hats, caps, or winter liners for added warmth. 100% polyester. Black.

Model	Type
B2396218	Neck Gaiter
B306073	Balaclava

B2329583



POLYETHYLENE GAS CANS

- Intuitive fuel dispensing, just press and pour
- Precision flow control for both limited- and large-capacity tanks
- Fastest 5-gallon flow rate
- CARB/EPA-compliant with auto shut-off and self-venting spout design

Model	Description	Cap. Gal.
B2329583	Gas Can, Red	5
B2329584	Diesel Can, Yellow	5
B2329585	Kerosene Can, Blue	5

300705



JOHN DOW 30-GALLON GAS CADDY

- Steel container for unleaded gas, diesel, kerosene, or mixed fuels.
- Cast iron 2-way rotary pump siphons or dispenses 1-gal per 12 revolutions
- Fire screened vent/fill level gauge and filler neck
- OSHA-compliant & UL-listed

JUSTRITE® SAFETY CANS

Engineered to help prevent flammables from igniting and to protect personnel from the dangers of fire and explosion. Flashback is prevented by a double-mesh flame-arrestor screen inside the spout. Spring loaded cap closes automatically after pouring.

420200



Model	Type	Cap. Gal.
420200	Type I	1
420206	Type I	5
420212	Type II	2
420214	Type II	5

FUEL YOUR BUSINESS & KEEP IT SAFE.

B2680334



CO2 FIRE EXTINGUISHERS

Carbon dioxide is discharged as a white cloud of "snow" that smother a fire by eliminating oxygen. It is effective for Class B flammable liquids and is electrically non-conductive.

Model	Lbs.
B2680334	5
B2680335	10
B2680336	15

B2680338



DRY CHEMICAL FIRE EXTINGUISHERS

ABC or multi-purpose extinguishers utilize a specially fluidized and siliconized mono ammoniumphosphate dry chemical. It chemically insulates Class A fires by melting at approximately 350°F and coats the surface to which it is applied. It smothers and breaks the chain reaction of Class B fires and will not conduct electricity back to the operator.

Model	Type	Lbs.
B2680341	ABC	2.5
B2680338	ABC	5
B2680339	ABC	10



DRENCH SHOWER

Shower is horizontally-mountable to the floor to provide quick access to overhead flushing of corrosive elements from affected areas. Pull rod-activated for immediate water flow. Includes ANSI-compliant identification sign. ETL listed 101496/ANSI Z358.1-2014. Also available in stainless steel: **708384SS**.



708563 REFILL BOTTLE

GRAVITY-FED PORTABLE EYEWASH STATIONS

This 20-gallon emergency eyewash station is portable and easily mounts to the wall of any nearby working location for quick access to eye flushing or spot washing. A drench hose on the side of the basin allows users to quickly spot-wash away chemical exposure on the body. Meets ANSI Z358.1-2009.

Model	Description
708387	Gravity-Fed Portable Eyewash Station
708563	Emergency Eyewash Preservative, 8 oz.



708381



708382

708383

EMERGENCY EYEWASH STATIONS

Emergency eye wash and shower stations are essential for industrial spaces where chemicals or hazardous substances are used. Eyewash basins have push handle activation for hands-free operation once unit is activated. Includes ANSI-compliant sign. ETL listed 101496/ANSI Z358.1-2014. Also available in stainless steel version; add suffix SS to model number.

Model	Description	Mount
708381	Eyewash Station	Wall
708382	Eyewash Station	Pedestal Floor
708383	Emergency Combo Shower & Eyewash Station	Floor



708570DS

EYEWASH BOTTLE STATIONS

Wall-mountable eyewash bottle stations provide quick response to eye accidents in work environments. Place within 10-second walk of potential hazard to provide immediate treatment to help an individual get to an ANSI-compliant eyewash station.

Model	Description	Size
708569SS	Single Bottle Station	16 oz.
708570SS	Single Bottle Station	32 oz.
708569DS	Double Bottle Station	16 oz.
708570DS	Double Bottle Station	32 oz.
708571	Universal Bottle Mount	Up to 32 oz.
708567	Replacement Bottle Only	16 oz.
708568	Replacement Bottle Only	32 oz.



708571



RDX-SERIES

- Improves productivity, customer service, loss prevention, and safety
- Meets Military 810 C, D, E, and F and IP54/55 specifications for shock-and extreme weather-resistance
- Lithium ion battery with up to 18.5 hours per charge
- Includes rechargeable battery, drop-in tray charger with power adapter, and 3" spring belt clip

Model	Mfg. #	Description	Range	Freq.
239874	RDU4100	4 Watt 10 Channel	350,000 Sq. Ft. 30 Flrs	UHF
239871	RDV5100	5 Watt 10 Channel	300,000 Sq. Ft. 18 Flrs	VHF

239874



CLS-SERIES

- Coverage: Up to 15 floors and/or 200,000 sq. ft.
- 56 frequencies and 121 interference codes
- 12 hr. lithium battery life / 3 hr. recharge time

Model	Mfg. #	Description
795371	CLS1110	UHF, 1 Watt 1 Channel
795372	CLS1410	UHF, 1 Watt 4 Channel

795371



B2158776



TALKABOUT®-SERIES

- Featherweight & compact design is comfortable to carry & use
- Set of 3 rechargeable radios with 22 channels to easily stay in touch
- Durable design is ideal for outdoor use
- Radios work in remote areas, eliminating need to rely on cell phone reception

Model	Mfg. #	Range	Color
B2158776	T200TP	Up To 20 Miles	Gray
B2158778	T260TP	Up To 25 Miles	White

EXCLUSIVE BRANDS



670549



670539

SAFETY MIRRORS

- Prevent injuries and discourage theft
- Lightweight acrylic surface is impact-resistant and durable
- Mirror is built with a molded plastic backboard for added safety and enhanced appearance
- Convex safety mirrors offer protection against intersection accidents at blind corners
- Wide-angle full-dome mirror provides an unobstructed view

Model	Description	Dia. 17
670547	Convex Mirror	26
670549	Convex Mirror	36
670542	180° Mirror	26
670543	180° Mirror	36
670539	360° Mirror	26
670540	360° Mirror	36

B729988



443244RD



MASTER LOCK® LOCKOUT STATION & PADLOCKS

The Lockout Station helps protect personnel from accidents and prevents unwanted or unsafe equipment operation. Add Safety 410-Series Padlocks for a complete system to protect your employees. Complies with "One Employee, One Lock, One Key" directive. Padlocks have a 1 3/4" tall thermoplastic body with 6-pin, reserved-for-safety cylinder with key retention to ensure padlock is not left unlocked, and are available in a variety of colors.

Model	Description
B729988	Lockout Center
443244RD	Safety Padlock, Red

EXCLUSIVE BRANDS

670487



670488



670477

SECURITY SEALS

- High-security bolt seal is designed to safeguard high-value cargo
- Fixed-length truck seal is compact, highly tamper-resistant and user-friendly
- Metal cable seals with non-preformed cable are ideal for trucks, containers, drums, rail cars, high value totes, and canisters
- Add color suffix to model number: RD - Red, BL - Blue, GN - Green, YL - Yellow, OR - Orange, WH - White

Model	DESCRIPTION
670487	High-Security Bolt Seal
670477	7 1/2" L Fixed-Length Truck Seal
670488	1/8" x 12" L Metal Cable Seal

ABSORBENT SOCKS

Easily wraps around leaky equipment and conforms to uneven surfaces. Specifically treated to absorb aggressive and nonaggressive liquids. Can be used around machines and drums.

670627



Model	Description	Cap. Gal.	Dia. " x L"	Pkg. Qty.
670627	Universal	13	3 x 12	12
670628	Universal	44	3 x 48	40
670629	Oil Only	44	3 x 48	40

ABSORBENT ROLLS

Universal rolls are all-purpose absorbents with great wicking for leaks, drips, and spills. Cost-effective alternative for larger spills. Rolls soak up both oil and water as well as grease, transmission fluid, hydraulic fluid, coolants, diesel fuel and many other fluids.

B2305914



Model	L' x W"	Cap. Gal.	Pkg Qty
B2305914	150 x 30	34	1/Bag
B2305915	150 x 15	41	2/Pack

SPILL KITS

Prepacked kits contain all the supplies needed to clean up and dispose of spills quickly & easily. Multiple sizes available for different applications.

B2305923



Model	Description	Cap. Gal.
B2305923	Truck Spill Kit, Zipper Bag	5
B2305924	Truck Spill Kit, Bucket	5
670674	Wheeled Spill Kit	30
670675	Spill Drum Kit	55
670676	Wheeled Spill Kit	65
670677	Spill Drum Kit	94



B2305918

ABSORBENT PADS

Universal absorbent pads are ideal for most spills, and oil-only pads absorb petroleum-based liquids. The go-to sorbent for emergency spill response. Hazmat pads safely clean up a wide range of toxic, flammable, corrosive, and aggressive liquids.

Model	Description	Cap. Gal.	L" x W"	Pkg. Qty.
670638	Hazmat Pads, Yellow	23	15 x 18	100
B2305919	Hazmat Pads, Yellow	22	15 x 18	100
670639	High Visibility Hazmat Pads, Yellow	23	16 x 18	100
B2305920	Hydrocarbon Based Oil Pad, White	21	15 x 18	100
B2305921	Hydrocarbon Based Oil Pad, White	22	16 x 20	100
670634	Oil Only Pads, White	24	15 x 18	200
670635	Oil Only Pads, White	18	15 x 18	100
670636	Oil Only Pads, White	22	15 x 18	100
B2305917	Universal Pad, Gray	15	15 x 18	100
B2305918	Universal Pad, Gray	22	15 x 18	100
670630	Universal Pads, Gray	28	15 x 18	200
670631	Universal Pads, Gray	22	15 x 18	100
670632	Universal Pads, Gray	26	15 x 18	100
670633	Universal Pads, Gray	50	30 x 40	50

670642



ABSORBENT MATS

Prevents industrial liquids from reaching floor, counters, or other surfaces. Versatile uses and durable construction. Won't rip, shred or fray even under heavy forklift traffic.

Model	Description	Cap. Gal.	L"
670642	Universal Sorbent Barrier Spill Mat	18	100
670641	Universal Sorbent BattleMat	64	150
670640	Universal High Traffic Sorbent Mat	44	300

670613



SPILL BERMS

Contain spills and prevent leaks around machines and equipment. Quick setup for easy containment of spills. Polyurethane material is resistant to oil and various chemical spills.

Model	Description	H"
670613	High Profile Connectable Spill Berm	4.5
670614	Low Profile Spill Berm	2.25

EXCLUSIVE BRANDS



PORTABLE RUBBER SPEED BUMPS

- Made of UV-resistant rubber for long-lasting durability and dependability
- Bumps maintain and control vehicle speed for high-traffic areas
- Molded cat-eye reflector tape enhances visibility
- Maintenance-free construction provides chemical-, weather-, and corrosion-resistance

Model	L"
708109	72
670528	48

EXCLUSIVE BRANDS



708147

708140

708136

TRAFFIC CONES

- Weatherproof orange PVC traffic cones have a weighted tip-resistant base
- Meets MUTCD standards
- Available in reflective or non-reflective

Model	Description
708147	Black Base, 7 Lbs.
708141	Orange Base, 10 Lbs.
708136	Orange Base, 2-1/2 Lbs.
708140	Orange Base, 7 Lbs.

EXCLUSIVE BRANDS

REFLECTIVE DELINEATOR POSTS

- 2 reflective 3" stripes for high visibility at night
- Snug-fitting base allows nesting when not in use for compact storage and easy transport
- 45"H Delineators are available with Orange, Blue, and White Posts
- Posts and bases also sold separately



670607

Model	Base	Color
670681	Square, 10 Lbs.	Orange
670682	Hexagonal, 16 Lbs.	Orange
670683	Square, 10 Lbs.	Blue
670684	Hexagonal, 16 Lbs.	Blue
670685	Square, 10 Lbs.	White
670686	Hexagonal, 16 Lbs.	White

EXCLUSIVE BRANDS



708111

RUBBER PARKING CURBS

- Made of recycled rubber for long lasting durability and dependability
- The structural integrity of this curb provides high impact-resistance
- Molded reflective tape improves driver visibility

Model	L"
670594	22
670595	36
670596	48
708111	72

EXCLUSIVE BRANDS



708173

RETRACTABLE CONE BAR

- Bright orange color with reflective tape for an effective high-visibility barricade
- Adjustable length from 5-8'L
- Durable ABS construction is impact- and corrosion-resistant
- Meets DOT and MUTCD specifications.



B1604473

INTERLOCK SAFETY BARRICADES

Direct traffic flow or cordon off hazards or construction with these high-density polyethylene barricades. Barrier sections can be filled with water or sand. These safety barriers offer high-visibility using reflective strips. Available in Orange, Natural, or Yellow.

Model	Color	Size (L" x W" x H")
B1604473	Orange	60 x 16 x 24
B1604474	Natural	72 x 18 x 36
672031	Yellow	71¼ x 24 x 43

EXCLUSIVE BRANDS



708184BK

MOLDED RUBBER CABLE PROTECTOR

- Molded rubber ramp protects hoses and cables from roll-over damage
- Black molded rubber has a slip-resistant traction surface and can withstand capacities up to 2,200 lbs.
- Interlocking ends allow multiple ramps to connect end-on-end



B2350321

PLASTIC SAFETY DRUMS

- Plastic traffic control drums bounce back after impacts
- Made from UV-stabilized bright orange high-density polyethylene
- Meets MUTCD standards
- Tire Ring Base model B2350244



CENTERMOUNT REFLECTORS

- Feature ultra-durable plastic back plate and plastic center hole
- Reflectors are 3¼" dia. and ¾" thick; center hole measures ¾"

Model	Color
B1504087	Red
B1504082	Amber
B1504088	Blue

EXCLUSIVE BRANDS

724216



724210



724226



OSHA SAFETY SIGNS

- Brightly-colored, easy-to-read signs help comply with OSHA standards
- “Danger” signs should be used where immediate hazards exist
- “Caution” signs warn against potential hazards and unsafe practices
- “Notice” signs convey important safety information
- Add material suffix: Vinyl (P), Aluminum (A), Plastic (R)

Model	Description	H" x W"
724216	Danger Keep Out	7 x 10
724210	Caution Do Not Enter	7 x 10
724226	Notice Authorized Personnel Only	7 x 10

724223RB



724220R



FIRE SAFETY SIGNS

- High-visibility design helps you quickly locate fire safety equipment in an emergency
- Safety glow is immediately visible in the event of a sudden blackout

Model	Description	Material	H" x W"
237910	Fire Extinguisher Sign	Vinyl Glow	18 x 4
724220R	Fire Extinguisher Sign	Rigid Plastic	18 x 4
724223RB	Fire Extinguisher Sign	Rigid Plastic	10 x 14

EXCLUSIVE BRANDS

NON-SKID FLOOR SIGNS

- Effectively convey safety messages
- Highly-visible, large 17" diameters are ideal for plants, factories, and warehouses
- Sub-surface printed on heavy-duty non-skid 10 mil clear vinyl with permanent adhesive



724237

Model	Description
724237	Danger Restricted Area Authorized Employees Only
724236	Caution Do Not Enter

708312



SOLAR-POWERED FLASHING LED SIGNS

- Highly-visible and bright LED
- Sign has visibility up to 2600 ft.
- Features a lithium ion battery that allows 5-7 days of operation per charge
- Heavy-duty aluminum and 3M reflective diamond grade film

708313



Model	Description	Size
708312	Stop Sign	30"
708313	Pedestrian Crossing Sign	30"



337530



337534

GRAPHIC FACILITY SIGNS

- High-visibility signs feature pictures and words to better communicate their message
- Choose pressure-sensitive vinyl or weather- and impact-resistant rigid plastic
- Add suffix "R" for Plastic or "P" for Vinyl

Model	Description
337530	First Aid
337534	Emergency Eye Wash

ANSI GRAPHIC SIGNS

- Universally-understood ANSI graphic signs for comprehension at a glance
- Safety alert triangle and headings indicate an immediate or potentially hazardous situation
- Meets ANSI Z535 guidelines
- Add suffix "R" for Plastic or "P" for Vinyl
- Measures 7"W x 10"H



952809



952824

Model	Description
952809	Caution - Forklift Traffic Area
952824	Emergency Shower
921171	Notice All Visitors Must Register
952819	Danger High Voltage

EXCLUSIVE BRANDS



708410BK



708414RD



708411YB

708417YB

CROWD CONTROL RETRACTABLE BELT BARRIERS

- Perfect for directing crowd control or blocking off restricted areas
- Barriers provide additional visibility, ensuring proper pedestrian control & safety
- 2"W nylon webbing
- Posts measure 40"H x 2½"D with 14 lb. weighted base
- Specify belt color suffix: Black (BK), Blue (BL), Red (RD), Yellow/Black (YB)

BELT STANCHIONS

Model	Description	Belt L"
708414	Black Post	7½
708413	Stainless Steel Post	7½
708417YB	Yellow Post, Yellow/Black Belt	11
708417BC	Yellow Post, Caution Belt	11

WALL MOUNT BELTS

Model	Description	Belt L"
708410	Wall-Mount w/ Receiver	7½
708411YB	Wall-Mount w/ Receiver, Caution Belt	15
708412	Wall-Mount w/Receiver, Yellow/Black Belt	30

PRODUCTS THAT STAND OUT FROM THE CROWD.

EXCLUSIVE BRANDS

SAFETY BARRICADE GATE

- Quickly and easily block access to dangerous or restricted areas
- Folded gate has a small footprint for easy storage
- All-steel construction with powder coat finish
- Expands to 20'L x 52½"H

652923



EXCLUSIVE BRANDS

954112YL

PLASTIC CHAIN AND STANCHIONS

- Keep aisles clear from moving traffic and secure sensitive areas
- 14" diameter base can be filled with sand for stability
- Use one post every 8' of area secured
- 41"H x 2½" diameter

708552WH

708552YL



B56183

RUBBERMAID® EXTENDABLE MOBILE BARRIER

- Limit access to areas with lightweight mobile barricade
- 16 yellow hi-vis articulating panels allow straight, curved, and circular configurations
- 13'L when opened; features four locking straps to keep barrier closed when not in use
- Includes two 5" dia. non-marring wheels for easy portability
- Barricade measures 2'L x 13"W when closed; 40"H overall

EXCLUSIVE BRANDS

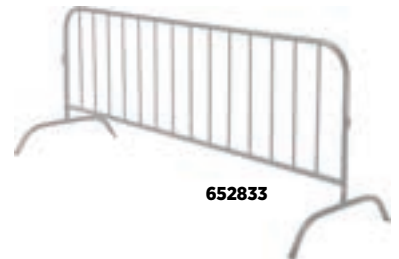

652833

PORTABLE SAFETY BARRIERS

- Direct pedestrians with all-welded steel barriers
- Easy to transport with removable feet
- Measures 108"L x 40"H

Model	Post Dia.™
652833	1¼
695008	1½



337328R

SURFACE BUMPER GUARD

Provide superior corner protection for people, machines, and objects around your facility with the bumper guards. Each polyurethane guard is easy to install, long-lasting, and durable and is able to absorb major impacts, as well as prevent injuries and damage to personnel and property. Their bright yellow and black design offers an effective warning to highlight danger at edges, gaps, or near obstacles in the workplace.

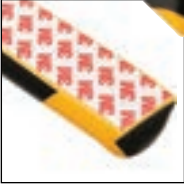

Model	Type	Shape
670673	C	Rounded
670672	G	Square
670670	B	Rounded
670671	E	Flat
670669	A	Rounded
670668	H	Flat
670667	H+	Flat

67057



REMOVABLE SAFETY BOLLARD

- Sharp yellow finish provides high visibility.
- Solid steel material construction ensures high level durability.
- Removable from the area, allowing flexible changes.

Model	Dia."	H"
670517	4	36
670518	6	36

238818RD



238818YL

BOLLARD POST SLEEVES

Bollard post sleeves resist fading, rusting, and cracking. High-density polyethylene construction for effective use outdoors. Available in ribbed or smooth surface. Add Suffix YL for Yellow and RD for Red.

Model	Dia."	H"
238818	5½	60
238819	7½	60
238820	9¼	60



708166YL



708163YL

COLUMN PROTECTORS

Column protectors measure 42" H and are made of high-density polyethylene for durability and corrosion-resistance. They absorb forklift and tow-motor impacts, minimizing column and machinery damage, and preventing personnel injury. Includes two black straps for easy installation.

Model	L" x W"	O.D"
708166YL	6 x 6	13
708163YL	8 x 8	24
708164YL	10 x 10	24
708165	12 x 12	24



B2217381

WILDECK® SAFETY BOLLARD

Bollards help protect warehouse equipment from scratches and dents, and employees from accidents, by creating a physical barrier from fork trucks. Strong square structural steel tubing is welded to a base mounting plate and topped with a galvanized steel cap.

337328R



INDOOR/OUTDOOR SAFETY BOLLARDS

- Use bollards to protect doorways and corners
- Yellow powder coat finish with black visibility stripes
- Also available in below-ground and removable mount styles



Model	H"
337326R	24
337327R	36
337328R	42

PROTECTIVE GUARD RAILS

- Highly visible, safety-yellow finish
- Welded base plates measure 10" sq. x 5/8" thick and are pre-drilled for easy installation.
- Rails constructed from 10-gauge high-tensile steel
- Bracket kit allows rail sections to slide into brackets attached to posts
- Assembly hardware included

Model	Description
436724	4'L Rail
436725	5'L Rail
436726	6'L Rail
436727	7'L Rail
436728	8'L Rail
436729	9'L Rail
436730	10'L Rail
436731	18"H Post - Single Rail
436732	42"H Post- Double Rail
436733	Bracket Kit (Pair) For Drop-In Style
320742	Concrete Mounting Kit



436733



708360YL

UNIVERSAL SAFETY GATE

- Spring-loaded swing gate serves as a protective barrier and to prevent unauthorized entry
- Rigid and durable steel tubing construction ensures years of reliable service
- Self-closing design automatically shuts safety gate
- Versatile adjustable-width gate accommodates various sized entryways from 24" to 40" wide.
- High-visibility yellow finish
- Meets OSHA 1910.23a, 1910.21 Subpart D

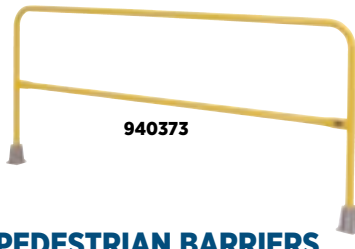

940373

PEDESTRIAN BARRIERS

- Ideal for directing personnel or traffic flow
- Heavy-duty 1½" diameter 42" high steel pipe frame with mid-rail for rigidity
- Order single or double sockets to form a straight row or angles up to 30° to create a curved barricade
- Meets OSHA requirements

Model	Description
940373	96"L Barrier
940372	72"L Barrier
940374	Single Socket Base
940375	Double Socket Base

OVERHEAD DOOR TRACK PROTECTORS

Protect delicate overhead door tracks from forklift, cargo, or vehicle damage with this heavy-duty steel guard. The 6" x 6" base plate has a 3" x 3" notch-out to accommodate the track, includes mounting holes and requires only 3 bolts (sold separately) for easy installation.



652894

Model	H"
652894	24
652895	36
652896	48

DROP-IN/LIFT-OUT LIGHT DUTY GUARD RAILS

Lift-Out/Drop-In light duty guard rail system offers effective protection for machinery against forklift and pallet trucks, while providing temporary access or barrier protection for pedestrian control. Guard rails are compact in design and easy to install; simply slide rails into posts. Constructed from 11-gauge steel with high visibility OSHA safety yellow powder coated finish. Ultra-durable construction with a 5,000 lb. impact rating at 4 mph.

Model	Description
708429	4'L Guard Rail
708430	5'L Guard Rail
708431	6'L Guard Rail
708432	7'L Guard Rail
708433	8'L Guard Rail
708434	9'L Guard Rail
708435	10'L Guard Rail
708436	20"H Single-Rail End Post
708437	20"H In-Line Single Rail Post
708439	20"H Single-Rail Corner Post
708440	42"H In-Line Double-Rail Post
708441	42"H Double-Rail End Post
708442	42"H Double-Rail End Post



708429

184904

SECURITY WIRE MACHINE GUARDS

Provides a highly visible barrier between employees and potential hazards such as dangerous machinery or conveyor belts. Panels feature durable 10-gauge wire construction and measure 5'H. Build to fit your space with connecting posts..

Model	Description
184902	3' Wall Panel
184903	4' Wall Panel
184904	5' Wall Panel
184910	Connecting Post



EASY-TO-INSTALL SAFETY AND SECURITY WHERE YOU NEED IT



603301

SECURITY ROOMS

Security rooms help protect important tools, merchandise, or other valuables by closing off a portion of backroom, warehouse, or floor space without building permanent walls or modifying your floor plan. Choose from a pre-configured kit or assemble a customized build-your-own room.

Model	Description	Size
603301	Sliding Door, No Roof	20' x 10' x 8'
603306	Sliding Door, No Roof	20' x 10' x 10'
603302	Sliding Door, No Roof	20' x 15' x 8'

BLUFF PRODUCTS REALLY STEEL THE SHOW.



WALL MOUNTED PIPE GUARDS

Pipe Guards protect exposed pipes, conduits, ducts, and downspouts from vehicle and forklift damage. Standard wall-mounted guard models are 36" or 46" tall, built of 3/16" thick steel, and fit pipe diameters from 2- 12 inches.



Model	Height	Pipe Size
B3080817	36	4"
B3080818	36	6"
B3080819	36	8"
B3080820	36	10"
B3080821	36	12"
B3080822	46	6"
B3080823	46	8"
B3080824	46	10"
B3080825	46	12"
B3080826	46	4"



Model	Size	Side	Color
B2114576	52"	Left	Black
B2114577	52"	Right	Yellow
B2114578	52"	Right	Blue
B2114582	42"	Double	Orange
B2114583	36"	Right	Blue
B2114584	36"	Left	Yellow
B2114585	36"	Right	Black
B2114586	36"	Right	Orange
B2114589	48"	Left	Blue
B2114592	42"	Double	Yellow
B2114593	42"	Left	Black
B2114594	42"	Left	Blue
B2114608	42"	Right	Orange
B2114615	36"	Right	Yellow
B2114616	42"	Right	Yellow
B2114623	42"	Left	Orange
B2114630	42"	Left	Yellow
B2114631	42"	Right	Black
B2114632	42"	Right	Blue
B2114636	48"	Double	Black

BLUFF RACK GUARDS

This heavy-duty Rack Guard can prevent, or lessen, the damage from forklift or pallet truck impacts. It has a wraparound design that protects the rack from both front and side damage and easily bolts to the floor for extra strength and stability.

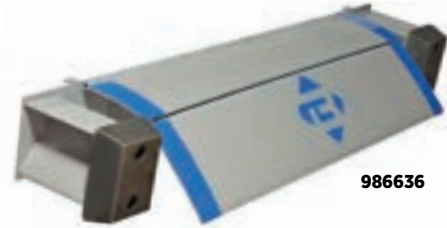

986636

EZ-PULL EDGE OF DOCK LEVELER

The Bluff® EZ-Pull Dock Leveler is positioned by lifting and pulling the self-storing handle to the dock floor. The latch assembly activates the leveler lip forward to the floor of the trailer as the handle is lifted. When released, the handle automatically returns to the stored position when truck leaves. Included with each unit are twin 12¾" x 10" bumpers that extend 16¾" from dock face. Durable 3/8" thick steel safety plate and heavy-duty hinges.

Model	Item Description	Width	Capacity
986636	EZ-Pull Mechanical Edge of Dock Leveler	78	20,000
986639	EZ-Pull Mechanical Edge of Dock Leveler	78	25,000
986637	EZ-Pull Mechanical Edge of Dock Leveler	66	25,000
986642	EZ-Pull Mechanical Edge of Dock Leveler	78	30,000
986647	EZ-Pull Refrigerated Truck Edge of Dock Leveler	72	25,000
986640	Z-Pull Mechanical Edge of Dock Leveler	66	30,000
986650	EZ-Pull Refrigerated Truck Edge of Dock Leveler	72	30,000
986645	EZ-Pull Refrigerated Truck Edge of Dock Leveler	78	20,000

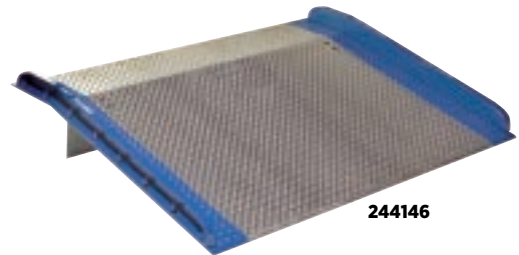

244146

ALUMINUM DOCK BOARD WITH STEEL CURBS

Ideal for warehouse settings, distribution centers, and manufacturing plants, this board combines the strength of steel with the lightweight properties of aluminum without compromising durability. Bolted-on steel curbs help prevent run-off and provides a handgrip for easy and safe handling during installation and removal. A safety stop on the underside of the board fits tight between truck and dock to prevent the board from moving during use. ANSI- and OSHA-compliant. Made in the USA.

ORGANIZE IT, SHELVE IT, STORE IT.

Take back control of inventory, improve assembly efficiency, and simplify parts organization with bins that are made for convenient placement and organization.



Plastic Stack & Hang Bin

Find it on page 31

MEDICAL & LABORATORY

141-147

EXCLUSIVE BRANDS



2453700



2453702



2453703



2453704



2453707

LABORATORY REFRIGERATORS & FREEZERS

- Seamless temperature control from a digital operating system
- Ideal for labs, medical rooms, pharmacies, etc.
- Large, easy-to-read front digital LED thermostat display
- Transparent glass swing door allows a clear view of stored contents from a distance

Model	Description	Cu. Ft. Cap.	Temperature Range
2453700	Glass Door Refrigerator	2.4	2° to 8°C
2453701	Glass Door Refrigerator	4.2	2° to 8°C
2453702	Solid Door Refrigerator	4.2	2° to 8°C
2453703	Glass Door Refrigerator	13.8	2° to 8°C
2453704	2 Glass Doors Refrigerator	31.4	2° to 8°C
2453705	Solid Door Freezer	3.2	-10° to -25°C
2453706	2 Solid Doors Freezer	17.3	-10° to -30°C
2453707	Solid Door Ultra Low Temp Freezer	3.5	-40° to -86°C

732109



DISPOSABLE MEDICAL FACE MASKS

- Suitable for use by clinical & medical personnel, masks are used during evasive and non-evasive procedures or when proper hygiene and safety protocols are required
- 3-ply protection provides a physical barrier to prevent direct penetration of blood splash, body fluids, bacteria, particulate matter, etc.
- One size fits a wide range of wearers

Model	Description	#/Box
732109	Level 1	50
732144IW	Level 2, Individually Wrapped	50
732144	Level 2	50
732145	Level 3	50

**YOU CARE FOR
YOUR RESIDENTS.
WE CARE FOR YOUR
FACILITY.**



B985206

BLUE STREAK WHEELCHAIR

- Large accommodating seating surface measures 20" wide
- Arm rests are fully padded for comfort
- High-quality frame, cross brace, and nylon upholstery are attractive and easy to clean
- Extremely durable solid rubber tires

EXCLUSIVE BRANDS

695749



695746



DIGITAL THERMOMETERS

- Accurate & easy to use
- Quick response times
- Displays in F° or C°

Model	Description
695746	Non-Contact Digital Infrared Forehead Thermometer
695749	Flex-Tip Oral Digital Stick Thermometer, Orange

EXCLUSIVE BRANDS

436963



DIGITAL PULSE OXIMETER

- Accurately and quickly measures oxygen saturation in 8 seconds
- High-definition OLED display screen
- Accommodates a wide range of finger sizes
- Lightweight and portable
- Carrying case and lanyard included



B985207

REBEL WHEELCHAIR

- Lightweight, high-strength, and extremely maneuverable
- Quick-release back wheels and folding frame for transport
- Flip-up armrests and swing-away footrests for easy transfers
- Large, accommodating seating surface
- 18"W seat, red frame

EXCLUSIVE BRANDS

CHROME HAMPER STAND

- Offers superior performance and a convenient way to transport large bags of laundry
- Chrome-plated steel is sturdy and easy to maintain
- Hands-free foot pedal raises the white, poly-coated steel lid for uncomplicated access



Model	Type
436911	Foot-Operated Hamper Stand
B2224897	Hamper Bag

EXCLUSIVE BRANDS

732141



MOBILE 3-PANEL PRIVACY SCREEN

- Provide your patients and guests with more privacy with this Mobile 3-Panel Privacy Screen
- Ideal for hospital settings, nursing homes, vaccination, or testing sites, these screens are easy to maneuver and store when not in use
- Instantly creates privacy where needed
- Non-transparent Panels
- Aluminum frame with double legs for stability
- Replacement panels sold separately - Model 732142

EXCLUSIVE BRANDS

B2222414



STAINLESS STEEL GLOVE BOX HOLDERS

- Constructed of durable stainless steel
- Easy to clean and disinfect
- Accommodates all single glove box sizes
- Can be installed vertically or horizontally
- Mounting holes and hardware provided for easy installation

Model	Capacity	W" x D" x H"
B2222414	Quadruple	21 x 3¾ x 10
B2222415	Triple	16 x 3¾ x 10
436949	Double	11 x 3¾ x 10
436955	Single	6¼ x 4 x 10



PATIENT MOBILITY

- Durable tracks grip stairs securely, regardless of stair material
- Unique seat design allows easy transfer from wheelchair
- Failsafe brake brings unit to a complete stop automatically

Model	Description	Cap. Lbs.
B2247358	Garaventa Lift Emergency Evacuation Chair	400
B1529875	Evacuation Stair Chair	400
B2179337	Evacuation Stair Chair With Foot Rest	500

732118



732117



SHARPS DISPOSAL CONTAINERS

- High-impact plastic for long-lasting durability
- Shatter- and puncture-resistant
- Locks for safe disposal
- Easily-accessible needle remover
- Meets or exceeds OSHA, NIOSH, CDC, and JCAHO standards

Model	Capacity	Lid Type
732117	2 Gallon	Slide Lid
732120	8 Gallon	Split Rotor Lid
732118	1 Quart	Flip Lid
732127	1 Quart	Slide Lid



GRAVITY CONVECTION LAB OVENS

- UL- and CSA-recognized components in all ovens
- Durable, well-crafted, and versatile

Model	Capacity	W"	Exterior H"	D"
B918776	2.0 cu ft	18	15 ⁵ / ₈	12
B918772	.7 cu ft	12	10	10
B918774	1.27 cu ft	13	13	13
B918713	3.0 cu ft	18	21 ³ / ₄	14



DEFIBRILLATOR PACKAGE WITH MOUNTING CABINET

- 2.4 lbs. in weight with a Pad-Pak installed
- Proprietary electrode technology and SCOPE™ biphasic technology adjusts automatically for different patient responses during rescue
- Easy to understand visual and voice prompts

Model	Description	L" x W" x H"
B1505637	Semi-Auto Defibrillator Package	11 ¹ / ₂ x 4 ¹ / ₂ x 11



2453701

MEDICAL REFRIGERATION

- Precise temperature control
- Lock prevents unauthorized access

Model	Description	Cu Ft	Door Type
2453702	Undercounter	4.2	Solid
2453701	Undercounter	4.2	Glass
B2346437	Pharmacy/Vaccine Undercounter	2.5	Solid
B2195385	Countertop	1	Solid



DUCTLESS FUME HOODS

- Designed to protect work surfaces, products, and materials from particulate contamination
- Multiplex® HEPA filtration technology to sustain the contamination-free environment.
- High-efficiency ebm-papst EC blower

Model	W"	D"	H"
B2173523	24	27	35
B2173524	48	27	35
B2173516	24	27	35



BOTTLE RACKS

- Holds trigger spray bottles, plunger spray bottles, or water bottles
- Sky-white epoxy finish

Model	Bottle Dia"
B2273700	up to 3.5
B2273703	up to 5
B2273702	up to 6.25



B1037889

PPE LAB DISPENSERS

- Keep disposable PPE organized
- Easy and convenient access for ease-of-use

Model	Description	Material
B3081605	PPE Wear Organizer	Wood
B1037889	3 Compart. Dispenser	Acrylic
B2354556	Quad PPE Dispenser	Stainless
B1037957	Lab Coat/Smock/Gown Dispenser	Acrylic



B2224647

LAB BOTTLES

- Wide mouth for easy filling
- Resistance to most acids, bases, and alcohols

Model	Capacity	Quantity
B2224648	250ml	250
B2224665	1L	24
B2224647	1L	50

EXCLUSIVE BRANDS



732138

PERSONAL PROTECTION SHIELDS

- Protects users from dangerous materials and liquids as they work
- Angled design minimizes glare

Model	Description	W" x D" x H"
732138	Small	8 x 10 x 18
732139	Medium	12 x 10 x 18
732140	Large	12 x 15 x 23

EXCLUSIVE BRANDS



732137

SPLASH GUARDS

- Equip washing stations with solid and upright splash protection
- Firm barrier prevents fluids, mixtures, and sprays from reaching surrounding equipment
- Portable for quick relocation
- The clear and compact design of the shield helps maintain sharp visibility for staff as they work

Model	Description	W" x D" x H"
732137	Small	4 ¹ / ₂ x 19 x 18
732136	Medium	4 ¹ / ₂ x 21 ¹ / ₄ x 18
732135	Large	4 ¹ / ₂ x 23 ¹ / ₂ x 18



670147

5-DRAWER MEDICAL BEDSIDE CART WITH KEY LOCK

- Ideal for use in hospitals, private medical practices, nursing homes, and more
- Heavy-duty steel construction with welded seams
- Features an easy-clean ABS plastic top and lockable drawers
- Rolls smoothly on four 2.5" swivel casters.
- 24½"L x 13¼"W x 29"H



436934

NEXEL® LINEN CARTS WITH COVER

- Ideal for use in medical or industrial facilities
- Nylon cover protects linens from airborne dust and dirt
- Rolls easily on 5" swivel casters (2 with brakes)

Model	Shelves	L" x W" x H"
436934	Galvanized Steel	60 x 24 x 69
436932	Galvanized Steel	48 x 24 x 69
436918	Chrome Wire	60 x 24 x 69
436916	Chrome Wire	48 x 24 x 69

SHOP MEDICAL & LABORATORY SUPPLIES



436959B

NEXEL® SLANT WIRE SHELVING SUTURE CARTS

- Rear-loading design assures stock rotation
- Constructed from sturdy chrome-plated steel
- 4 angled shelves provide 400-lb. capacity and adjust in 1" increments
- Shelves feature 4¼"H retaining front lip to keep contents in place

Model	L" x W" x H"
436959B	48 x 24 x 69
436956B	36 x 18 x 69



436948

MAYO INSTRUMENT STAND WITH MOBILE BASE

- Five casters on the base provide sturdy footing and mobility
- Includes a removable stainless steel tray that measures 19¼" x 12¾"
- Tray height adjusts from 30" to 50" and is secured in place by a lock



436960

NEXEL® STERILE WRAP RACKS

- Provide a safe & convenient place to hold sheets
- Wire bottom shelf, standard on all units, can be used to hold extra wraps
- Ergonomically-designed rack positions wrap at waist height for easy access

Model	Description	L" x W" x H"
436960	Low Profile	18 x 60 x 40
B2256461	High Profile	24 x 60 x 68



695436

35" - 51"

MOBILE COMPUTING WORKSTATIONS

- Designed for mobile computer transport and access
- Provide secure laptop and keyboard access
- Easy height adjustment
- Smooth-rolling, balanced, and stable

Model	Shelves	W" x D" x H"
695436	Mobile Standing Workstation	22 x 24½ x 55½
607300	Mobile Desktop Station	26 x 26 x 73
695421	Mobile Laptop Station	26 x 26 x 53¼
309235BKA	Mobile Computer Cart	27 x 24½ x 41



436910

OVERBED TABLES WITH H-BASE

- Ideal for activities involving patients in chairs, wheelchairs, or beds
- High-quality laminate top
- Steel H-base provides stability
- Smooth-operating, easy-lift spring mechanism for height adjustment
- Heavy-duty options available with capacity up to 100 lbs.

Model	Description	Cap. Lbs.	Color
436910	Standard	40	Walnut
436910WH	Standard	40	White
436965WN	Heavy Duty	100	Walnut
436965WH	Heavy Duty	100	White



B2273853



B2273855

NEXEL® CATHETER CARTS

- Holds all styles and sizes of catheter packages
- Catheter hooks are easily secured onto bars and can be adjusted to accommodate peel pouches
- Plastic label holder attaches to end of hook to identify type of catheter by style, size or application

Model	Description	W" x L" x H"
B2273853	Catheter Procedure Cart	60 x 24 x 68
B2273854	Catheter Procedure Cart	48 x 24 x 68
B2273855	Catheter Cart with Baskets	48 x 24 x 68

EXCLUSIVE BRANDS

STEP STOOLS

- Constructed with sturdy and durable 1" diameter chrome steel tubing
- Anti-slip ribbed rubber platform
- Reinforced rubber tips on the legs for stability

Model	Description	Cap. Lbs.
B2181734	Step Stool	350
B2181733	Step Stool With Handrail	350
436957	Bariatric Step Stool With Handrail	500
436961HR	Two-Step Foot Stool With Handrail	500

B2181734



436957



PORTABLE FOLDING WALKER

- Lightweight aluminum frame with a steel cross brace helps provide durability and stability
- Easy-to-use, pushbutton mechanisms let walkers fold easily
- Comfortable hand grips and non-marking tips
- Weight capacity is 350 lbs.
- Adjustable height from 32" to 39"



B1596610

SHOP MEDICAL & LABORATORY SUPPLIES

EXCLUSIVE BRANDS

NARCOTICS CABINET

- Organizes, secures, and protects medications from abuse, misuse, and theft
- Heavy-gauge steel with chip- and scratch-resistant finish
- Features double door with double lock for enhanced security; locks are keyed different
- Two adjustable and removable shelves
- 16"W x 8"D x 24"H

436951



B522158A



240152ABK



EXCLUSIVE BRANDS

PHYSICIAN STOOLS

- Stable and slim design ensures easy maneuvering
- Cushion provides firm support that softens and contours to your body over time
- Pneumatic height-adjustment
- Durable, versatile black vinyl covering is easy to maintain
- Available with antimicrobial treatment to fight microbes and bacteria

Model	Description
240152ABK	All Purpose Mobile Stool
240159ABK	Antimicrobial Medical Stool
B522158A	Medical Stool with Backrest and Footring
240160ABK	Antimicrobial Medical Stool with Backrest

PLUMBING & PUMPS

148-153

EXCLUSIVE BRANDS



WALL-MOUNTED BOTTLE FILLING STATION

- Bottle filling station only or combo drinking fountain & bottle station
- 3,600-gallon filter included
- Refrigerated
- 1.0 GPM laminar flow spout reduces splashes
- Touchless, sensor-activated bottle filler
- ADA-compliant, NSF-certified

Model	Type
761218	Single Water Cooler & Bottle Filling Station
761243	Bi-Level Water Cooler & Bottle Filling Station
761219	Bottle Filling Station Only
761215	Pure™ Replacement Water Filter

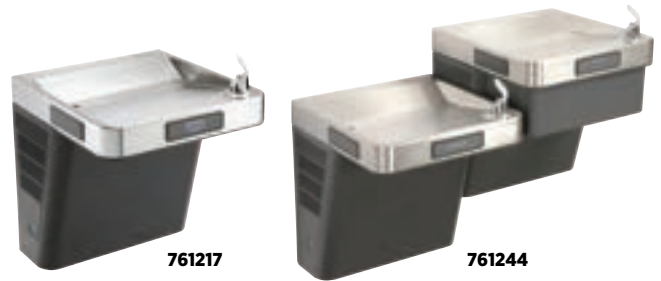

WALL-MOUNTED FILTERED WATER COOLER

- 3,600-gallon filter included
- Refrigerated, with adjustable thermostat
- Flexible safety bubbler
- Keyed-access water filter door
- ADA-compliant, NSF-certified

Model	Type
761217	Single Cooler
761244	Bi-Level Cooler



TOP-LOAD WATER DISPENSERS

- Accepts 3- or 5-gallon water bottles
- Space-saving design
- Ships fully assembled
- Dispenses hot, cold, and room temperature water
- LED indicator lights

Model	Type	W" x D" x H"
670438	Counter Top	14 ³ / ₁₆ x 15 ³ / ₁₆ x 23 ³ / ₄
670437	Floor	14 ³ / ₁₆ x 15 ³ / ₁₆ x 42 ¹ / ₄

BOTTLELESS WATER COOLERS

- Contemporary design
- Dispenses hot, cold, and room temperature water
- Connects directly to water supply
- Available with UV water filter
- LED indicator lights

Model	W" x D" x H"
670436	14 ³ / ₁₆ x 16 x 45
670435	15 ³ / ₄ x 15 ¹ / ₄ x 44 ³ / ₁₆

670435





603601



761221BL



761222GN



761224GN



761224BK

OUTDOOR BOTTLE FILLING STATIONS

- Available in stainless steel or rugged polyethylene construction with granite finish
- Vandal-resistant bubbler
- 1.0 GPM laminar flow spout reduces splashes
- Corrosion-resistant for outdoor use
- Choose from four configurations in four finishes
- Available with 3,600 gallon water filter

Model	Description	Color
761222GN	Pedestal Bottle Filling Station	Green
761221BL	Bottle Filler w/Bi-Level Drinking Fountain & Pet Station	Blue
603601	Drinking Fountain with Bottle Filler	Granite



670434

84" H OUTDOOR SHOWER

- Ideal for beaches
- Includes 2 nozzles and 2 pushbuttons
- Stainless steel finish
- Durable 2.5mm-thick stainless steel with 4mm base
- 100% lead-free waterways

Model	Color	L" x W" x H"
670434	Stainless Steel	12 x 12 x 84



761223



761223BL

OUTDOOR DRINKING FOUNTAINS

- Corrosion-resistant stainless steel construction
- Vandal-resistant bubbler
- Pushbutton activation
- Choose from two styles, four finishes
- Pedestal models available with 3,600 gallon water filter

Model	Type	Color	L" x W" x H"
761224	Wall	Stainless Steel	10¼ x 7¼ x 16¼
761224GN	Wall	Green	10¼ x 7¼ x 16¼
761224BL	Wall	Blue	10¼ x 7¼ x 16¼
761224BK	Wall	Black	10¼ x 7¼ x 16¼
761223	Pedestal	Stainless Steel	14 x 14 x 37½
761223GN	Pedestal	Green	14 x 14 x 37½
761223BL	Pedestal	Blue	14 x 14 x 37½
761223BK	Pedestal	Black	14 x 14 x 37½

ELKAY® WATER REFILLING STATIONS

- 1.1 GPM fill rate is 3X faster than traditional fountains
- Hands-free bottle filler with 20-second shut-off
- Available with 3,000-gallon water filter
- Flexi-Guard antimicrobial safety bubbler
- Pushbutton front & side bars activate bubbler
- Requires 115V power
- Bi-level versions available for most models



B384182NG



B606767

ELKAY® SURFACE MOUNT WATER BOTTLE REFILLING STATIONS

- Designed for installations with limited wall depth
- Available with pushbutton or electronic activation
- 115V stations feature touchless activation and auto 20-second shut-off
- Filtered units include a 3,000-gallon capacity filter
- Optional remote chiller (sold separately)

Model	Filter Included	Color	Part #
ENHANCED MODEL			
B384182NG	Yes	Light Gray	LZS8WSLP
B384183NG	Yes	Stainless Steel	LZS8WSSP
STANDARD			
B384182N	Yes	Light Gray	LZS8WSLK
B384183N	Yes	Stainless Steel	LZS8WSSK
806156N	No	Light Gray	EZS8WSLK
B1890600	No	Stainless Steel	EZS8WSSK

Model	Power	Filter	Part #
806246	Non-Electric	No	EMASM
B606767	115V	Yes	LZWSSM
B1890599	Battery	No	EMASMB
B1890605	Battery	Yes	LMASMB
B606768	115V	No	EZWSSM

SHOP OUR FULL LINE OF ELKAY® PRODUCTS



B639788N

ELKAY® BOTTLE FILLER RETROFIT KIT

- Transform any Elkay push bar-activated water cooler into a refilling station
- 1.0 GPM fill rate for refrigerated units; 1.5 GPM for non-refrigerated units
- Sanitary, no-touch sensor activation with auto 20-second shut-off timer
- Available with or without a filter

Model	Filter Included	Part #
B639787N	No	EZWSRK
B639788N	Yes	LZWSRK
B639788N	Yes	HTHD-HAC-RF-SS



B190402

ELKAY® ADA-COMPLIANT WALL-MOUNTED WATER COOLERS

- Flexi-Guard antimicrobial safety bubbler
- Single or bi-level fountains available
- Sensor units feature hands-free operation
- Available with 3,000-gallon water filters
- Provides 8 GPH of chilled water
- Requires 115V power
- Bi-level versions available for most models

Model	# of Stations	Color	Filter	Part #
B190402	1	Light Gray	No	EZS8L
B190341	1	Light Gray	Yes	LZS8L
B190442	2	Light Gray	No	EZSTL8LC
B190443	2	Stainless Steel	No	EZSTL8SC
B190343	1	Stainless Steel	Yes	LZS8S

EXCLUSIVE BRANDS



670448



670455

STAINLESS STEEL WALL-MOUNT SINK

- For industrial, commercial, or educational settings
- 16-gauge stainless steel
- For hand washing or tool cleaning
- Deep basin contains splashes
- Available with or without faucet, knee valve
- NSF-listed

Model	L" x W" x D"	Includes
670448	14 x 10 x 5	Faucet
670453	14 x 10 x 5	Faucet w/ Knee Valve
670454	14 x 10 x 5	Faucet w/ Knee Valve
670455	14 x 10 x 5	Sink Only
670458	14 x 10 x 5	Knee Valve
670459	14 x 10 x 5	Knee Valve



B721315



B721310

ACORN ENGINEERING COMPANY® WASHFOUNTAINS

- For heavy-duty use in commercial and industrial applications
- Pre-assembled and tested for quick installation
- Waste connection and pressure-balancing mixing valve
- Infrared sensor models are hard wired
- Various styles and mount types

Model	Style	# Stations
B721315	Semi-Circular, Foot Operated	3
B721320	Semi-Circular, Foot Operated	2
B721310	Elliptical, Foot Operated	4
B721312	Circular, Foot Operated	8

AMERICAN STANDARD WALL-MOUNTED BATHROOM SINKS

- For commercial, industrial, or residential use
- White vitreous china
- Rear overflow
- Soap depression
- Options include one or three holes for faucets on 4" or 8" centers (faucet not included)



B32017

Model	L" x W"	Faucet Holes	Faucet Centers"
806198	18½ x 17	3	4
B32017	20½ x 18¼	1	---
B32016	20½ x 18¼	3	8
B32020	20 x 27	3	10.5
B32019	20 x 27	3	4

EXCLUSIVE BRANDS



670457



670456



252978

STAINLESS STEEL UTILITY SINK

- Ideal for commercial kitchens, workshops, studios, and more
- Deep basin and backsplash contain splashes
- 18-gauge stainless steel construction
- Available with or without faucet
- NSF-approved and non-NSF-approved options

Model	NSF Listed	L" x W" x D"	Faucet Included
670451	Yes	18 x 18 x 12	Yes
670456	Yes	18 x 18 x 12	No
670452	Yes	24 x 24 x 12	Yes
670457	Yes	24 x 24 x 12	No
252978	No	24 x 24 x 14	No
252979	No	24 x 24 x 14	Yes



B744812



B744815

FIAT® MOP & LAUNDRY SINKS

- Made from sheet molding compound (SMC)
- For mop sink, drain is molded into a one-piece unit that connects to a 2" or 3" drainpipe
- Drain connector assembly and strainer pipe included
- Faucet and supply lines not included

Model	Description	Mount Type	L" x W" x H"	Part #
B744815	Laundry Tub	Free Standing	23 x 21½ x 36¾	FL1100
B744816	Laundry Tub	Free Standing	40 x 24 x 33¾	FLTD1100
B744812	Mop Basin	Floor	24 x 24 x 10	MSBID2424100
B744811	Mop Basin	Floor	36 x 24 x 10	MSB3624100



B2245509

761207

670460

SENSOR-OPERATED BATHROOM FAUCETS

- Faucet-only models are ideal as replacements or single-temperature operation
- Models with mixing valves deliver consistent, safe water temperature
- Auto shutoff
- ADA-compliant

Model	Brand	Includes	Holes	GPM
761207	Global Industrial	Faucet, Mixing Valve	1	1
670460	Global Industrial	Faucet Only	1	2.2
B252720	Sloan	Mixing Valve	3	0.5
B2245509	Krowne	Mixing Valve	3	2.2



B2169950

186571

FOOD SERVICE DECK- AND WALL-MOUNTED FAUCETS

- Ideal for heavy-duty use in any high-volume commercial setting
- Deck-mount or wall-mount with swing or goose neck
- Stainless steel or solid brass
- With 4" or 8" center faucet mounting holes

Model	Mount	Centers"	Spout Reach"	Style	Brand
B548804	Deck	4	7½	Gooseneck	T&S Brass
B2169837	Deck	4	10	Swing	Krowne
B2169846	Wall	4	3½	Gooseneck	Krowne
B2169950	Wall	8	8½	Gooseneck	Krowne
B2169949	Wall	8	6	Gooseneck	Krowne
186571	Wall	8	12	Swing	Equip By T&S
B2169952	Wall	8	8	Swing	Krowne

B344694



PRE-RINSE UNITS

- For commercial or industrial food service settings
- Flexible steel hose directs spray where needed
- Several riser heights available to accommodate different sink sizes
- Deck-mount or wall-mount

Model	Mount	Centers"	GPM	Brand
B344692	Deck	---	1.42	T&S Brass
B344694	Wall	8	1.42	T&S Brass

W/Add On Faucet					
Model	Gpm	Riser H"	Hose L"	Spout Reach"	Brand
B2169974	1.8	18	36	12	Krowne
B2169804	1.2	8	24	8	Krowne



761210



B67172

URINAL/TOILET SENSOR-ACTIVATED FLUSH VALVE RETROFIT KITS

- Provides automatic flushing for toilets and urinals
- Made of metal, plastic, brass, and stainless steel
- Battery-operated
- Vandal-resistant models available
- Gallons per flush (GPF) and sensor ranges vary

Model	Brand	GPF	Sensor Range
761210	Global Industrial	1.6	15" - 30"
761211	Global Industrial	1.5	15" - 30"
B67172	Zurn	3.5	8" - 50"
B67173	Zurn	3.5	8" - 50"



761208

URINAL/TOILET SENSOR-OPERATED FLUSH VALVES

- Safe and effective at limiting the spread of bacteria and viruses
- Infrared sensor
- ADA-compliant
- Available in a variety of brands and types

Model	Brand	Style	GPF
761208	Global Industrial	Urinal	1
761209	Global Industrial	Toilet	1.6
236684	Sloan	Toilet	1.6
236686	Sloan	Urinal	1.6

STAINLESS STEEL FITTINGS

- Stainless steel resists corrosion from industrial and chemical solutions
- Meets the following specifications:
Material: 304 stainless steel, Threads: ANSI B1.20.1, Dimensions ISO49



Model	Fitting Type	Size
B1874993	Coupling	1
B1875049	90 Degree Elbow	1
B1875176	Union	1
B1874997	Tee	1

B2374666

BALL VALVES

- Full Port
- Dezincified brass resists corrosion
- Sweat or threaded connections
- 400-600 PSI CWP



Model	Brand	Size"	Connection
B2374666	Legend Valve	½	Threaded
B2374665	Legend Valve	¾	Threaded
B2374664	Legend Valve	1	Threaded
B2374661	Legend Valve	2	Threaded

MORE THAN 5,000 PLUMBING VALVES AND FITTINGS AVAILABLE

EXCLUSIVE BRANDS

DRAIN CLEANING MACHINES

- Ideal for plumbers, maintenance workers, and homeowners
- Available in hand-held and drum-style machines
- Clean lines from 3/4" to 10"
- Unclogs sinks, pipes, and toilets



Model	Description	Cables Included
670462	Electric Auto-Feed Handheld Drain Cleaner	25' x 3/16" Bulb Auger
670465	Electric Handheld Drain Cleaner	3 Cables
670439	Drain Cleaner For 2-4" Pipe	75' x 3/8"
670440	Electric Auto-Feed Drain Cleaner	75' x 1/2"
670441	Drain Cleaner For 4-9" Pipe	100' x 3/4"



BUTTERFLY VALVES

- BUNA seals resist oil, water, solvents, and hydraulic fluids

Model	Size	Type
B438212	2	Lug
B438182	2	Wafer

B213885

PIPE LOCATION & INSPECTION

- Pinpoints water leaks in residential and commercial water lines
- Identifies leaks through concrete slabs, in walls, swimming pools, and hot tubs
- High-performance headphones with noise cancellation
- Sound amplification manifold adds air to the line to amplify the sound



761202

EXCLUSIVE BRANDS

WATER TRASH PUMPS

- For general-purpose use, high-pressure transfer or flood recovery
- Reliable Honda engines
- Low-oil sensor automatically shuts off the engine if oil level drops too low
- Corrosion-resistant seals and a durable cast iron impeller on 2", 3" and 4" models



Model	Style	Output"	Horsepower	GPM
761202	Water	2	7	158
761203	Water	3	7	264
761204	Trash	2	7	158
761205	Trash	4	14	458

PACKAGING & SHIPPING

154-159

EXCLUSIVE BRANDS

Up to
10,000 lb.
capacity



236466

LOW-PROFILE PALLET SCALES

- LCD display with backlight features six ½"H digits
- RS-232 serial port connectivity. Battery/AC power (adapter included)
- Optional ramp available

Scale	Cap. Lbs.	W" x L"
242434	10,000	48 x 48
242433	5,000	48 x 48

EXCLUSIVE BRANDS



DIGITAL SHIPPING SCALE

- Easy-to-read digital display
- Large keys for print/hold, unit, tare and on/off
- Powers off after 2 minutes of non-use, saving energy
- Uses either an AC adapter or 6-AA batteries

Model	Cap. Lbs.	Kg.	Accuracy Lbs.	Kg.
318513	400	180	0.5	0.2

B1856979

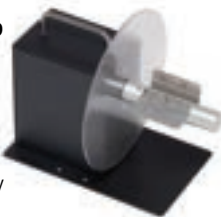

LABEL REWINDERS

- Rewinders wind-up labels into a roll as they come out of a printer
- Heavy-duty construction provides lasting durability
- Equipped with a dancer arm designed to help eliminate liner breakage

Model	Label Width		Feed Speed Inch/Sec.	Dia."
	Min.	Max.		
B1856979	¾	4½	108	8½
B1856980	¾	4½	108	8½
B1856978	¾	6½	244	12

412616



MANUAL LABEL DISPENSERS

- Heavy-duty steel construction
- Holds 1" core labels. 3" core adapters included
- Features non-skid suction bases

Model	Maximum	
	Roll W"	Roll D"
412614	6	6
412615	10	6
412616	12	6

EXCLUSIVE BRANDS

244280



60 lb.
capacity

ELECTRONIC COUNTING SCALE

- High-accuracy for small items in pounds and kilograms
- Powered by a 12V DC 500mA adapter or a 6V 4Ah lead-acid rechargeable battery
- ABS plastic housing and stainless steel components are strong and impact-resistant

Model	Capacity		Readability	
	Lbs.	Kg.	Lbs.	Kg.
244280	60	30	0.002	0.001

EXCLUSIVE BRANDS



POST HEIGHT ADJUSTS
FOR TABLE TOP OR
FLOOR APPLICATIONS



EASY-TO-READ 1"H
NUMBERS



660 lb.
capacity

BENCH/FLOOR SCALE

- Operating functions include auto-zero, tare, accumulate and counting, and auto-shutoff with sleep mode
- LCD displays six 1"H digits for easy viewing
- Adjustable posts remove quickly and easily
- 6'L power cord; 115V AC with built-in rechargeable battery

Model	Capacity		Readability		W" x L"	Ht. Adj."
	Lbs.	Kg.	Lbs.	Kg.		
244241	330	150	0.1	0.05	11¼ x 19½	18½ to 41½
244242	660	300	0.25	0.1	15¾ x 23¾	18½ to 51

B449972



SEMI-AUTOMATIC TWIST TIE MACHINE

- Unique straight-line ribbon feed avoids twist tie ribbon jam ups
- UL-approved
- Constructed of all metal components
- Capable of tying up to 50 bags/min

EXCLUSIVE BRANDS



412410

SEMI-AUTOMATIC STRETCH WRAP MACHINE

- Allows simplified pallet wrapping for packaging, shipping, and storage
- Adjust film stretch and film force on your load with the turn of a knob
- Optional approach ramp provides access with a pallet jack



Model	Description
412409	Semi-Automatic Machine
412410	Ramp

EXCLUSIVE BRANDS



244292

244284

STRETCH WRAP CUTTERS

- Enables safe and efficient cutting
- For use on multiple wrapping materials including stretch film, twine, bubble wrap, foam, and more
- Plastic handle

Model	Description	Pkg. Qty.
244292	Heavy-Duty Stretch Wrap Cutter	2
244284	Stretch Wrap Cutter	6



DR. SHRINK MARINE AND INDUSTRIAL SHRINK FILM

- Used for covering large products against damage in transportation or storage
- Available in a variety of widths, lengths, thicknesses, and colors
- Long-lasting durability and dependability

Model	Size	Mil	Color
B923252	40"W x 100'L	8	White
B923083	17"W x 120'L	6	Clear

EXCLUSIVE BRANDS



STRETCH WRAP

- Provides protection, stability, and tear-resistance during transport
- Used to wrap and secure products on pallets
- Helps to reduce product loss & discourage load tampering
- Available in a variety of widths, thicknesses, and types

Model	Gauge	W" x L"	Color	Ctn. Qty.
HAND STRETCH WRAP				
412547	70	18 x 1500	Clear	4
412546	80	18 x 1500	Clear	4
412549	80	5 x 1000	Clear	12
412551	80	18 x 1500	Blue	4
MACHINE STRETCH WRAP				
412548	80	20 x 5000	Clear	1

START YOUR DAY BY WRAPPING THINGS UP.

EXCLUSIVE BRANDS



B450072

STRETCH WRAP DISPENSER

- Use to manually apply stretch wrap to pallets and bundles
- Lightweight and compact for quick roll changeover
- Provide even wrapping with consistent tension for superior packaging and wrapping

Model	Type
B450072	Pistol Grip
244294	Extended Reach



249330

SHRINKFAST HEAT GUN

- Quick and easy shrink wrapping and shrink-film processing
- Can shrink wrap a 40"W x 48"D x 60"H pallet in less than 2 minutes
- Lightweight design weighs only 2.2 lbs



CORRUGATED CARDBOARD BOXES

- Protect contents for everyday shipping
- 200#/ECT-32 kraft corrugated
- Available in a variety of widths, lengths, and heights

Legacy#	L" x W" x H"
B0012969	10 x 8 x 6
B012951	10 x 10 x 10
B0012957	12 x 12 x 12
B012960	18 x 18 x 18



CORRUGATED MAILERS

- Perfect for shipping small, lightweight, fragile items
- 200#/ECT-32, B flute white corrugated
- No tape, glue, or staples needed

Model	L" x W" x H"	Color
B1638385	15 x 2 x 2	White
B2205512	5 x 4 x 2	Kraft
B40174	8 x 3 x 2	White

CARTON SIZER

- Customize your carton size by safely and easily scoring the inside wall
- The printed ruler ensures accuracy for precision cuts every time



244282



412405

BOX CUTTERS

- Precision cutting for warehouses, packaging areas, receiving departments
- Built for strength and impact-resistance

Model	Type	Qty./Box
412405	Box Cutter	6
795281	Box Cutter	12
412406	Multi-Function	12
412407	All-in-One	1

CARTON STAND

- Organize corrugated boxes for easy access
- Chrome-plated finish
- Optional casters available



184205

Model	Description	H"
184205	Dual Level	78½
184204	Single Level	38½



SHIPPING CRATES

- Crate ships and stores flat, saving money and space
- ¼" plywood provides strength and durability
- Buckle and slot system allows for safe and easy assembly
- Meets ISPM-15 international shipping requirements

Model	L" x W" x H"
B2352211	47¼ x 47¼ x 42½
B2352214	47¼ x 39¼ x 36½

EXCLUSIVE BRANDS

318522



PALLET CONES

- Prevent double stacking
- Cones tape or strap down
- Reduces damage to shipments

Model	Description	Color
318522	English Only	White
412402	English, Spanish, French	Yellow

EXCLUSIVE BRANDS

412420



PALLET CONTROL CONES

- 3-sided shape allows high visibility from all angles
- Color-coded for organization and inventory management
- Available in a variety of styles and colors

Model	Type	Color
412420	w/ Dry Erase	Blue
412422	w/ Dry Erase	Green
412427	Plain	Orange

EXCLUSIVE BRANDS

HAND-GRADE POLYPROPYLENE STRAPPING

- For use with hand strapping tools and strapping carts
- Retains loads better than steel or nylon strapping
- Available in a variety of sizes



241114

Model	Length'	Break Core"	Strength Lbs.
422817	5400	16 x 6	800
241114	9000	8 x 8	300
422815	7200	16 x 6	500

EXCLUSIVE BRANDS



921266



FREE

Roll of 1/2" White Polypropylene Strapping with each Strapping Machine

POLYPROPYLENE STRAPPING MACHINE

Semi-automatic; straps packages quickly and efficiently. Tension gauge adjustment allows operator to quickly change settings. Accommodates strapping from 1/4" to 5/8"; tension range of 10-100 lbs. Applies 24 straps per minute. Accepts packages with a minimum size of 2 1/2"W x 1"H; unlimited maximum size. Solid state circuitry to eliminate down time. 110V AC. Height adjustable.

EXCLUSIVE BRANDS

BATTERY POWERED AUTOMATIC STRAPPING TOOL

- Tensions, seals, and cuts in one easy operation
- Automatic or manual mode
- Includes two Bosch Lithium Ion batteries



412657

Model	Strap W"
412657	1/2
412658	5/8

SEALLESS STEEL STRAPPING TOOL

- Eliminates the need for seals
- Can be used for horizontal and vertical strapping
- Accepts strap widths including 1/2", 5/8" or 3/4"



412417

EXCLUSIVE BRANDS

UNIVERSAL POLYPROPYLENE AND STEEL STRAPPING CART

- Used for either steel or polypropylene strapping
- Ensures even, trouble-free unwinding
- Storage compartment for tools and seals



241121

POLYESTER STRAPPING SEALS

- Ensure a secure grip
- Maintain alignment and tension
- Available in a variety of sizes and styles

Model	Description
652680	Serrated Seals for 1/2" (1000/ctn)
652681	Serrated Seals for 5/8" (1000/ctn)



652680

EXCLUSIVE BRANDS



412559

SEMI-AUTOMATIC RANDOM-SIZE CASE SEALER

- Easy-to-operate, fast-functioning process is ideal for mailrooms, warehouses, and factories
- Provide consistent seals on packages to ensure secure closure for shipping
- Improve productivity and reduce poor seals, retaping, and returns

CARTON SEALING TAPE

- Provides extra strength for packaging protection
- Adheres instantly to a variety of surfaces
- Edge tear-and split-resistance
- Dispense by hand or machine, available in different thicknesses, lengths, & widths



418627CL

Model	Mfg No.	Mil	W" x Yds.	Case Qty.
418627CL	371	1.8	2 x 110	36
418721C	373	2.5	2 x 55	36
423067	HP200	1.9	3 x 110	24
422745	HP100	1.6	2 x 110	36
B2280775	311+	2.0	3 x 110	24

WATER-ACTIVATED KRAFT SEALING TAPE

- Handles applications from light- to heavy-duty
- Requires water to activate glue on tape
- Available in a variety of sizes and colors



Model	W"	L'	Color	Case Qty.
B2273258	3	375	Tan	8
422834	2 ¹¹ / ₁₆	375	Tan	8
422836	3	450	Tan	10

EXCLUSIVE BRANDS



795451

HEAVY-DUTY TAPE DISPENSER

- Quick and efficient tape wrapping
- Available in a variety of styles and tape sizes

Model	Size"
795451	2
185421	3



EXCLUSIVE BRANDS



412477

KRAFT TAPE DISPENSERS

- Provides fast and efficient packaging
- Compact design minimizes footprint
- Easy to move and relocate
- Available in manual and electric

Model	Type	Min Tape W'	Max Tape W'
412477	Electric	1/2	3
706390	Electric	1/2	3
300713	Manual	8/10	4

REINFORCED STRAPPING TAPE

- Designed for sealing, reinforcing, or strapping
- Supports palletizing, bundling, and securing loads
- Available in a variety of mil thicknesses and sizes



B2311621

Model	W" x Yds.	Mil.	Rolls/ Case
B2311621	3/4 x 60	4	48
B862640	1 x 60	4.5	36
B862520	1/2 x 60	4.5	72

EXCLUSIVE BRANDS



244222

IMPULSE BAG SEALER

- Seals poly bags and other thermoplastic materials, like polyethylene and polypropylene, quickly and efficiently
- No warm up time necessary
- Easy to operate: set the timer; insert the bag between the sealing bars, then press down and release

Model	Width	Seal Width
244222	12	2mm
244223	16	2.6mm

STAY PREPPED AND READY TO SHIP ANYTHING



POLY-TUBING ON A ROLL

- Cut to any required length
- Heat-seal, staple, or tape closed
- Seal at one or both ends
- Available in a variety of sizes and mil thicknesses

Model	W" x L'	Mil. Thickness
B013751	8 x 3000	2
B1308080	4 x 1075	4
B1308334	12 x 1075	4

EXCLUSIVE BRANDS



244269

DUNNAGE BAGS

- High-strength polywoven construction is moisture- and pressure-resistant
- Includes a push-and-lock valve for rapid deflation and air leakage prevention
- Available in a variety of sizes

Model	Size"	Pkg. Qty.
244269	48 x 48	25
244255	36 x 48	30
244267	36 x 84	20

EXCLUSIVE BRANDS

BUBBLE MAILERS

- Keep your items securely enclosed while in transit
- Peel-and-stick lip
- Available in a variety of sizes and bag numbers



Model	W" x L"	Type	Bag #	Qty./Case
412529	7½ x 12	Self-Seal	#1	100
412530	8½ x 12	Self-Seal	#2	100

EXCLUSIVE BRANDS

POLY MAILERS

- Provide lightweight protection for your products
- Mailers require less postage than standard boxes
- Available in a variety of sizes and bag numbers



Model	W" x L"	Type	Bag #	Qty./Case
412518	6½ x 10	Bubble Lined	#0	250
412516	4 x 8	Bubble Lined	#000	500

418200L



1000 Bags Per Case

ZIPPER-LOCK POLY BAGS

- Clear view of contents, or labels to identify contents
- Low-cost reusable bags are waterproof, and they keep dirt and moisture away from contents
- Available in a variety of sizes and mil thicknesses

Model	W" x L"
418211L	6 x 9
B44314	10 x 12
418205	4 x 6

OFFICE & SCHOOL SUPPLIES

160-163

EXCLUSIVE BRANDS



695260

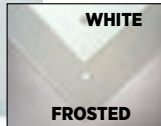

GLASS MARKER BOARDS

- No ghosting or staining
- Includes eraser, markers and holder, 4 heavy-duty magnets and mounting hardware
- Magnetic glass version available in various colors

Model	W" x H"	Magnetic	Color Finish
695260	48 x 36	Yes	White
695466	48 x 36	No	Frosted
695259	72 x 48	Yes	White
695467	72 x 48	No	Frosted

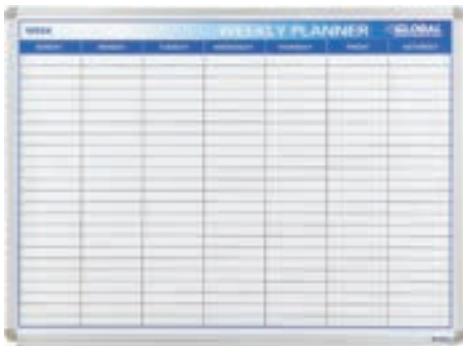

695815

DRY ERASE/PLANNING WHITEBOARDS

Templates on dry erase surfaces help you to stay organized and up to date. Choose from various surface types.

Model	W" x H"	Planning Period	Magnetic	Surface Material
695529	48 x 36	1 Month	Yes	Glass
695815	48 x 36	One Week	Yes	Painted Steel
695784	48 x 36	1 x 2 Grid	Yes	Painted Steel



695316

WALL MOUNT WHITEBOARDS

- Includes accessory tray
- Aluminum frame
- Available in additional sizes
- Scratch, stain, and bacteria-resistant

Model	W" x H"	Surface Material	Magnetic
695316	72 x 48	Melamine	No
B880012	72 x 48	Painted Steel	Yes
695478	72 x 48	Porcelain	Yes



695839



695526

DRY/WET ERASE MARKERS AND ERASERS

Write, chart, and brainstorm on any non-porous whiteboard surface.

Model	Style	Tip Type	Package Qty.
695526	Dry Eraser	-	1 Pack
695694	Wet	Bullet	4 Pack
695527	Dry	Bullet	4 Pack
695839	Dry	Bullet	8 Pack
695527F	Dry	Fine	4 Pack
695527K	Dry Kit	Bullet	1
695695BK	Dry	Bullet	12
695526PK	Dry Eraser	-	6



MOBILE REVERSIBLE WHITEBOARDS

- Double-sided to provide twice the functional writing space
- 360° board rotation on pivot hinge
- Great for collaborative use
- Mobile for easy transport
- Includes accessory tray
- Available in additional sizes and surface materials

Model	W" x H"	Frame Color
B444999	72 x 48	Silver
B444999BK	72 x 48	Black
B1854285	96 x 48	Silver
B1854285BK	96 x 48	Black
B444997	48 x 36	Silver
B444997BK	48 x 36	Black



MOBILE GLASS BOARDS

- Double-sided to provide twice the functional writing space
- Tempered glass; won't dent, stain, or ghost
- Mobile for easy transport
- Includes set of markers, magnets, and eraser
- Available in additional sizes and surface materials

Model	W" x H"	Color
695638	36 x 48	White
695693	72 x 48	White
695638BK	36 x 48	Black
695693BK	72 x 48	Black

CORKBOARDS

- Self-healing cork surface
- Thin profile
- Aluminum frame
- 4-corner mounting system
- Can be installed vertically or horizontally



Model	W" x H"
695463	36 x 24
695318	48 x 36
695492	60 x 36
695319	72 x 48
695320	96 x 48

ENCLOSED CORKBOARDS

- Self-healing cork surface
- Full-length door hinge
- Shatter-resistant acrylic windows
- Lockable doors with keys



Model	W" x H"	Doors
695875	18 x 24	1
695481	24 x 36	1
695757	36 x 48	1
695482	48 x 36	2
695758	60 x 36	2
695542	72 x 48	3
695542	48 x 36	2 sliding
695873	72 x 48	2 sliding



RECYCLED RUBBER BULLETIN BOARDS

Self-healing tack surface holds up under repeated use. The colorfast surface resists stains and fading and is easy to maintain. The board surface is manufactured using 90% post-industrial recycled rubber and the anodized satin-finish aluminum frame contains 75% post-industrial material. 10-year warranty. Made in the USA.

Model	W" x H"
B1481055	72 x 48
B1481066	48 x 36
B1481011	36 x 24



FABRIC MESH BULLETIN BOARDS

- Self-healing fabric mesh for a modern aesthetic
- Eco-friendly and made of recyclable materials
- Mounting hardware and pushpins included

Model	W" x H"	Color
695876	36 x 24	Black
695876GY	36 x 24	Gray
695877	48 x 36	Black
695877GY	48 x 36	Gray
695878	72 x 48	Black
695878GY	72 x 48	Gray



184450



184450B

NEXEL® GARMENT STORAGE

- Durable chrome-plated or black epoxy steel wire design
- Resists denting, chipping, and rusting
- Shelf adjusts on 1" increments
- Adjustable leveling feet

Model	W" x D" x H"	Color Finish	Shelf Qty.
184450	36 x 24 x 74	Chrome	3
184450B	36 x 24 x 74	Black	3
184449	60 x 24 x 63	Chrome	2
184449B	60 x 24 x 63	Black	2



695312

INTERION® WALL COAT RACKS

- Wall-mounted design saves floor space
- Solid welded steel
- 6 round-ended hooks

Model	Color
695312	Black
695313	Silver



695826



695310



695311

NEXEL® COAT TREES

- Freestanding, portable
- Durable powder coat steel frame
- 4 double hooks

Model	Color
695310	Black
695311	Silver



695715

695716



695767



INTERION® COAT RACKS

- Wall-mounted design saves floor space
- Rounded points help reduce damage to garments

Model	W" x H"	Color	# of Hooks
695715	36 x 6½	Silver	5
695718	20 x 3	Silver	4
695716	18 x 2	Silver	3
695768	2 x 6½	Silver	2
695767	2¾ x 2¾	Silver	1

INTERION® WALL-MOUNT COAT & TOWEL RACKS WITH SHELF

- Simple, wall-mounted rack with shelf
- Durable construction with attractive chrome finish

Model	W" x D" x H"
695825	24 x 14¾ x 17
695826	36 x 14¾ x 17
695827	48 x 14¾ x 17
695828	60 x 14¾ x 17



B781260



B181339

SHREDDERS

Shredding prevents unauthorized access to secure data and makes disposal of sensitive documents safe and easy. Accepts paper, staples, paper clips, CD/DVDs, and credit cards.

Model	Description	W" x D" x H"	Sheet Cap.	Security Level
B181339	Powershred 99Ci	11 ¹ / ₁₆ x 17 ³ / ₁₆ x 25 ³ / ₁₆	18	P-4
B781260	Securio P36c	22 ³ / ₄ x 21 ¹ / ₁₆ x 37	31	P-4



B1014460



252130

LAMINATORS & BINDERS

Binding and laminating machines create professional documents and presentations. Laminators seal documents inside a protective coating. Binding Machines are available in electric or manual options and make documents look professional and high-quality.

Model	Description	W" x D" x H"
B1014460	Photo & Document Laminator	14 ³ / ₁₆ x 6 ⁵ / ₈ x 2 ¹ / ₄
252130	Quasar™ Electric Comb Binding Machine	16 ⁷ / ₈ x 16 ³ / ₈ x 5 ¹ / ₂



B1398920



B685816

MARTIN YALE® MAILROOM EQUIPMENT & MACHINES

Ideal for schools and small businesses, these machines prepare documents and mailings in a quick and efficient manner. Letter Openers offer hands-free operation to open stacks of envelopes. Paper Folders automatically feed and create different fold types.

Model	Description	W" x D" x H"	Sheet Cap.
B1398920	Desktop Letter Opener	7 ³ / ₄ x 9 ¹ / ₂ x 3 ³ / ₄	1
B685816	Electronic Paper Folder	32 ¹ / ₂ x 15 ¹ / ₂ x 13 ¹ / ₈	150



B2353742

DAHLE® ROTARY PAPER TRIMMER

For use in the home or office, rotary trimmers ensure clean, straight edges on paper, presentation materials, crafts, and pictures. Rotary trimmers are more portable than guillotine-style trimmers and are ideal for more detailed projects.

Model	W" x D" x H"	Cutting L"	Weight Lbs.
B2353742	15 ¹ / ₂ x 22 ⁷ / ₈ x 3 ³ / ₈	14	7.3

MULTIFUNCTION PRINTERS & SCANNERS

- This multifunction printer balances speedy performance, minimal maintenance, and the ability to add an extra paper tray. A 5" color touchscreen delivers an intuitive user experience. Compatible with Mac® and Windows® operating systems.
- Wireless compact desktop scanner with 20-page auto document feeder quickly scans single and double-sided, color, and black-and-white materials up to 25 ppm in a single pass. Wi-Fi or USB connection. Highly portable. Dedicated card slot. Compatible with Windows®, Mac® and Linux®.



B2366003



B2396354



B1729316

ATTENDANCE AND TIME CLOCKS

Accurately track employee time and company costs with time and attendance clocks. Time Clocks use a "punch clock" system where employees use a time card to record their work hours. Automated Clock Systems replace the use of paper with swipe cards, badges, or key fobs.



B1001516

CALCULATORS

Microban protection, a large 12-digit display with punctuation and two-color heavy-duty printer ribbon. Print 4.5 lines per second. A wide variety of functions for quick, efficient calculations Calculator runs on AC power.

FOODSERVICE & RETAIL

164-166

EXCLUSIVE BRANDS



REACH-IN REFRIGERATORS & FREEZERS

Commercial-grade stainless steel refrigerators have aluminum interiors, adjustable steel shelves and bright, incandescent interior lighting. Exterior thermometer controls refrigerator and freezer temperatures. Energy-efficient R290 refrigerant.



243008

Model	Type	Shelves	Doors	Cu. Ft.	W" x D" x H"
243007	Refrigerator	3	1	23	29 x 32¼ x 82½
243008	Refrigerator	6	2	47	54 x 32¼ x 82½
243035	Refrigerator	9	3	72	80¾ x 32¼ x 82½
243009	Freezer	3	1	23	29 x 32¼ x 82½
243010	Freezer	6	2	47	54 x 32¼ x 82½
243036	Freezer	9	3	72	80¾ x 32¼ x 82½



GLASS DOOR MERCHANDISERS

Refrigerators & freezers conveniently and attractively display food and beverages. Energy-efficient double-pane glass doors. Aluminum interior and PVC-coated wire shelves are easy to clean. Includes energy-efficient lighting for high visibility. NSF-certified.



243006

Model	Type	Doors	Shelves	Cu. Ft.	W" x D" x H"
243005	Refrigerator	1 - Swing	4	23	28¾ x 31¼ x 79¾
243006	Refrigerator	2 - Sliding	8	45	53¼ x 31¼ x 79¾
243037	Refrigerator	3 - Swing	12	53	78¾ x 30 x 84¾
243050	Freezer	1 - Swing	4	23	28¾ x 31¾ x 84¾
243038	Freezer	2 - Swing	8	45	53¾ x 31¾ x 84¾
243055	Ice Freezer	2 - Swing	2	45	53¾ x 31¾ x 79¾



REACH-IN GLASS DOOR REFRIGERATORS & FREEZERS

The Nexel® Reach-In Glass Door series is a convenient and easily-accessible choice for cold food storage. Equipped with 2 transparent glass doors, durable stainless-steel construction, and PVC wire-coated shelving, this refrigerator is ideal for storing perishable goods in restaurants, kitchens, and cafeterias. Each unit features an embedded digital thermostat with LED display that makes it easy to adjust to below freezing temperatures, ensuring your foods and drinks stay fresh over time.



243219

Model	Type	Shelves	Doors	Cu. Ft.	W" x D" x H"
243218	Refrigerator	3	1	23	29 x 32¼ x 82½
243219	Refrigerator	6	2	47	54 x 32¼ x 82½
243220	Freezer	3	1	23	29 x 32¼ x 82½
243221	Freezer	6	2	47	54 x 32¼ x 82½



REACH-IN SPLIT DOOR REFRIGERATORS & FREEZERS

The Nexel® Reach-In Split Door series provides reliable cold food and drink storage around the clock, making it perfect for high-traffic businesses from convenience stores to quick-service restaurants. Equipped with split doors to reduce energy costs; durable stainless-steel construction, and PVC wire-coated shelving, these freezers & refrigerators are ideal for holding large quantities of products. Embedded digital thermostats make it easy for operators to change the temperature as needed.



243215

Model	Type	Shelves	Doors	Cu. Ft.	W" x D" x H"
243214	Refrigerator	3	2	23	29 x 32¼ x 82½
243215	Refrigerator	6	4	47	54 x 32¼ x 82½
243216	Freezer	3	2	23	29 x 32¼ x 82½
243217	Freezer	6	4	47	54 x 32¼ x 82½

SHOP ALL REFRIGERATION

243211



REFRIGERATED OPEN-DISPLAY MERCHANDISER WITH CURTAIN

This open unit conveniently offers up chilled goods and beverages. Resilient plastic or stainless-steel exteriors provide strong impact resistance and durability. Models include 3 adjustable shelves. Energy-efficient R290 refrigerant. Includes a transparent curtain to save energy at night. Temperature range 35-50°F.

Model	Cu. Ft.	Construction	W" x D" x H"
243209	8.8	Stainless Steel Shell	24 x 29 ¹¹ / ₁₆ x 67 ¹ / ₈
243210	13.8	Plastic Shell	36 ³ / ₁₆ x 33 ³ / ₁₆ x 59 ³ / ₈
243211	13.8	Stainless Steel Shell	36 ³ / ₁₆ x 33 ³ / ₁₆ x 59 ³ / ₈



243081



CHEST FREEZERS

Nexel® Chest Freezers hold bulk amounts of food that need to stay frozen. With a slim design, these models are easy to use, secure, & maintain. Units are perfect for restaurants, convenience stores, ice cream shops, and other businesses. Each model has ample room & includes a removable interior basket for smart storage organization. Best suited for placing in stock rooms where staff exclusively handle frozen goods. This cooler features a metal body with paint and an aluminum interior. Stark white color finish.

Model	Baskets	Cu. Ft.	W" x D" x H"
243080	1	4.95	30 x 22 x 33
243081	1	10	44 x 25 ¹ / ₂ x 33
243082	2	15.4	60 ³ / ₈ x 29 x 33

243207



REFRIGERATED COUNTERTOP DISPLAY CASE

Display cold treats, pastries and more on your countertop. The clear front and sides offer high visibility and the adjustable shelves offer flexibility. Durable stainless steel exterior. Models include 2 adjustable shelves. Double sliding-glass back doors for fast customer service. Eco-friendly R290 refrigerant provides a temperature range of 32-53.6°F.

Model	Cu. Ft.	W" x D" x H"
243207	4.2	27 ³ / ₈ x 22 ⁵ / ₈ x 27
243208	4.8	34 ³ / ₈ x 22 ⁵ / ₈ x 27



243206



ICE CREAM FREEZERS & DIPPING CABINETS

Easily store frozen soft-serving goods in both the Nexel® Ice Cream Freezer and Dipping Cabinet. Both are an essential storage choice for ice cream parlors, stores, and businesses that offer ice cream or cold desserts in a quick-service fashion. The freezer is designed with 2 curved glass doors that are built to retain cold air while maintaining clear visibility of contents. Removable baskets



243202K

for quick and easy replacement of contents. The dipping cabinets offer glass sneeze guards to help prevent contamination and ice cream holders with extra bottom storage to ensure full service of frozen treats. Both styles have LED interior lighting to provide strong illumination, white painted steel interior & highly efficient Eco-friendly R290 refrigerant. Transportable on 4 wheels; 2 are lockable to secure positioning.

Model	Type	Holds	Doors	Cu. Ft.	W" x D" x H"
243205	Freezer	3 baskets	2	6.7	39 x 28 x 34 ¹ / ₂
243206	Freezer	4 baskets	2	9.2	49 ³ / ₈ x 28 x 34 ¹ / ₂
243202K	Dipping Cabinet	6 tubs	1	7.4	39 x 28 x 52
243203K	Dipping Cabinet	10 tubs	1	13	60 x 28 x 52
243204K	Dipping Cabinet	12 tubs	1	16	71 x 28 x 52

242942



COMMERCIAL MICROWAVE OVEN

Heavy-duty stainless-steel 1000W microwave accommodates high-traffic environments. Intuitive controls and sturdy door handle. Automatic cool-down fan runs for 60 seconds after each use to prevent overheating. Accommodates 12" platters. ETL-certified.

Model	Type	Cu. Ft.	W" x D" x H"
242942	Dial	0.9	20½ x 17 x 12¼
242945	Digital	0.9	20 x 17 x 12¼
242943	Digital	1.1	20½ x 15¼ x 12

242969



243057



COMPACT REFRIGERATORS & FREEZERS

Energy-efficient compact and mid-size refrigerators and freezers are ideal for small spaces. Refrigerators feature adjustable shelves, half-width freezers and door storage. Freezers include 2 adjustable shelves.

Model	Type	Color	Cu. Ft.	W" x D" x H"
242969	Refrigerator	Black	2.6	19⅞ x 19⅞ x 24⅞
242944	Refrigerator	Black	1.7	17½ x 19 x 19½
243056	Freezer	Black	3.1	21⅞ x 22⅞ x 33½
243057	Freezer	White	3.1	21⅞ x 22⅞ x 33½

WHEN SERVICE HEATS UP WE HELP COOL THINGS OFF

243028



SELF-CONTAINED UNDER-COUNTER ICE MACHINES

These units produce high-quality, crystal-clear ice cubes and feature ample ice storage with automatic overflow prevention. Stainless steel construction with plastic bin door. Includes ice scoop, water filter, and drain hose. ETL- & ETL-Sanitation-approved for commercial use.

Model	Ice Prod./24 hrs.	W" x D" x H"	Storage
243027	120 Lbs.	19¾ x 23¼ x 35½	40 Lbs.
243028	160 Lbs.	26 x 27¼ x 38½	80 Lbs.
243029	210 Lbs.	26 x 27¼ x 38½	80 Lbs.
243030	280 Lbs.	26 x 27¼ x 38½	80 Lbs.

243031



MODULAR ICE MACHINE WITH STORAGE BIN

This durable stainless-steel unit is also low-maintenance, with an easy self-clean system. Air cooled and reliable; produces high-quality, crystal-clear ice cubes. Flip-up stay lid with LED light. Auto shut-off. Ice scoop included. NSF- and ETL-approved for commercial use.

Model	Ice Prod./ 24 hrs.	Storage	W" x D" x H"
243031	350 Lbs.	230 Lbs.	23⅞ x 33¾ x 67⅞
243021	500 Lbs.	275 Lbs.	31⅞ x 33⅞ x 67⅞

**GIVE IN TO THE PRESSURE WITH
OUR FULL SUITE OF PNEUMATICS.
WE GOT THIS.®**



From deburring grinders to jackhammers to automated machines and excavators, many of your favorite products and places were built using pneumatics. We stock all your favorite brands plus a full line of private label products to fit your needs... that won't break the bank.

TOOLS & INSTRUMENTS

168-177

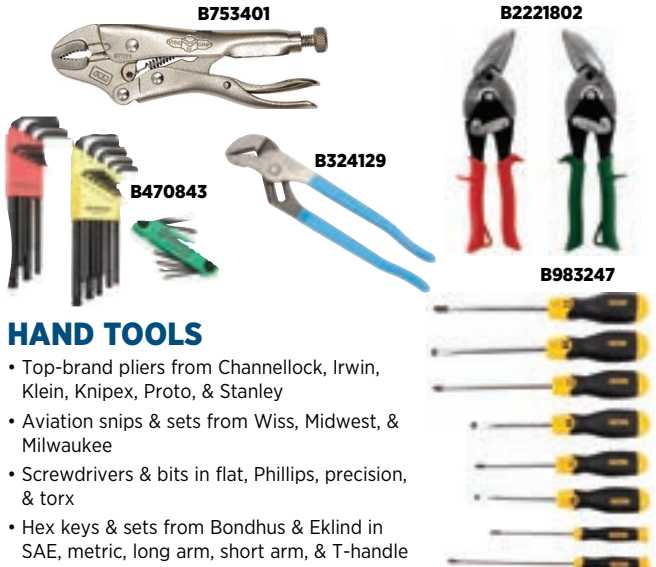

HAND TOOLS

- Top-brand pliers from Channellock, Irwin, Klein, Knipex, Proto, & Stanley
- Aviation snips & sets from Wiss, Midwest, & Milwaukee
- Screwdrivers & bits in flat, Phillips, precision, & torx
- Hex keys & sets from Bondhus & Ekling in SAE, metric, long arm, short arm, & T-handle

Model	Description
B324129	Channellock® 9½" Straight Jaw Tongue & Groove Plier
B753401	Irwin VISE-GRIP® 7" Curved Jaw Locking Plier W/ Wire Cutter
B2221802	Midwest Tool 2 Piece Left & Right Offset Aviation Snip Set
B983247	Stanley 8 Piece Cushion Grip Screwdriver Set
B470843	Bondhus 22 Piece SAE/Metric Hex Set W/ Free 8 Piece Torx Fold-Up



HOSE REELS

- Top brand reels from Reelcraft, Coxreels, Legacy Manufacturing, & Global Industrial
- Available in low-, medium-, or high-pressure configurations
- Durable powder coat steel construction, or stainless steel for food or corrosive environments
- Spring retractable, manual hand rewind, & motor driven options available

Model	Description	Pressure Rating	Hose Included
534173	Global Industrial™ ¾" x 50' 300PSI Spring Retractable Steel Hose Reel	Low	Yes
B584404	Coxreels ¾" x 35' 1250 PSI Spring Retractable Hose Reel	Medium	Yes
B250743	Reelcraft ½" x 50' 500 PSI Stainless Steel Spring Retractable Hose Reel	Low	No



TOOL & SOCKET SETS

- Top brand sets from Crescent, Channellock, Proto, Sunex, & Stanley
- Ratchets & sockets feature a manufacturer limited lifetime warranty
- Sets include blow-molded cases for secure storage & transportation

Model	Description
761236	Crescent® 180 Piece Mechanics Tool Set
B1963336	Sunex Tools 43 Piece ½" Drive SAE Standard & Deep Impact Master Socket Set
B248154	Stanley 201 Piece Mechanics Tool Set



UTILITY KNIVES & BLADES

- Available in fixed, retractable, snap-off, & self-retracting safety knives
- Trapezoid, snap-off, round point, & blunt edge options available for basic or safety requirements
- Blade disposal containers allow safe & easy disposal of discarded blades

Model	Description
B323582	Starrett Hidden Edge Self-Retracting Safety Utility Knife
B323307	Stanley Heavy Duty Utility Blades W/Dispenser (100 Pack)
B323304	Stanley Blade Disposal Container
B223847	Irwin Self-Retracting Safety Utility Knife W/No-Slip Handle



B1403275



B1106759



700187



B1403533

CORDLESS POWER TOOL COMBO KITS

Cordless tool combo kits are solidly made for long-lasting durability. Choose from assorted combos from top name brands. All include lithium-ion batteries and/or chargers, cases.

Model	Description	Kit Includes	Voltage
B1403275	Milwaukee®; 2696-26 M18 ; Cordless Lithium-Ion 6-Tool Combo Kit	Hammer Drill/Driver, Impact Driver, Recip Saw, Circular Saw, Grinder, Light, Charger	18V
B1106759	DeWALT® 20V MAX* Lithium Ion Combo Kit (1.5 Ah), DCK280C2, 2-Tool Kit	Impact Drill and Drill Driver	18V
700187	Makita®; XT269M 18V Brushless Cordless Hammer Drill & Impact Driver Combo Kit 4.0Ah	Impact Drill and Drill Driver	18V
B1403533	Milwaukee® 2498-24 M12 Cordless 4-Tool Combo Kit	Drill, Impact Driver, Saw, Work Light, (2) Batteries, Charger, Bag	12V



B1222389



B379899



B885679



B379900



B546536



B1854778

CORDED AND CORDLESS DRILLS

Power drills are a must for driving fasteners into wood, plastic, metal, and other hard surfaces. Choose from a wide variety of ergonomic designs in cordless and corded models. Speeds vary per model. Batteries included with some models.

Model	Description	Voltage	Chuck Size"
B1222389	DeWALT® DCD771C2 20V MAX Li-Ion Cordless 1/2" Drill/Driver Kit (2) Bat 1.3Ah Charger & Contractor Bag	20	1/2
B379899	Milwaukee® 2606-22CT M18 1/2" Cordless Compact Drill/Driver Kit	12	1/2
B379900	Milwaukee® 0299-20 1/2" Magnum Drill, 0-850 RPM	120	1/2
B1854778	Makita®; XFD03Z 18V LXT; Lithium-Ion Cordless 1/2" Driver-Drill (Tool Only)	18	1/2
B885679	BOSCH® 1006VSR, 3/8" Inch Corded Drill	120	3/8
B546536	Metabo®; BE 75-16 1/2" Drill	120	1/2

B1820322



B2397485



B246860



B438588

B243269



B803567



B243301



B243238



CORDED AND CORDLESS SAWS

Power saws are available in several styles with corded and cordless power to meet any application. Choose from Reciprocating, Chop, Band, Circular, and Miter from the most well-known manufacturers.

Model	Description	Voltage	Type
B243269	Milwaukee®; 6538-21 15.0 Amp Super Sawzall®; Reciprocating Saw	120	Recip Saw
B1820322	DeWALT®; DCS331M1 20V MAX Jigsaw Kit (4.0 AH)	20	Jigsaw
B2397485	Makita®; LXT®; Cordless 6 1/2" Plunge Circular Saw Kit, Lithium Ion, Brushless, 5.0Ah, 36V	36	Circular Saw
B438588	BOSCH®; JS260, 6.0A Top-Handle Jigsaw	120	Jigsaw

CORDLESS POWER SCREWDRIVERS

Cordless screwdrivers provide a superior power-to-weight ratio for improved torque control during continuous driving applications. Milwaukee®, DeWalt®, and Makita® drivers are rechargeable. General Tools driver operates on AAA batteries. Sizes, speeds, and voltages vary for different applications.

Model	Brand	Type	Voltage	Drive Size
B803567	General Tools	Precision Driver with Bits	---	1/8" Hex
B435128	DeWalt®	Driver w/ LED Light	12V	1/4" Hex
B243238	Milwaukee®	M12TM Driver w/ LED Light	12V	1/4" Hex
B243301	Milwaukee®	M4TM Two-Position	4V	1/4" Hex
B246860	Makita®	Two-Position w/ Auto Stop	7.2V	1/4" Hex

MITER SAWS

Miter saws feature powerful motors for precise cuts and long lasting durability. Blade sizes are 10" and 12". Operating styles, dimensions, and operating speeds vary per model. Miter saw accessories such as stop kits, wing kits, and quick clamps are sold separately. Dimensions and additional specifications vary per model.



B1035177



B885623



B246918



B2836505

Model	Description	AMPS	Sliding	Blade Size"	Compound	RPM	Max Cut"
B1035177	DeWALT® DWS780 12" Double Bevel Sliding Compound Miter Saw, 3800 RPM	15	Yes	12	Yes	3800	16
B885623	BOSCH® GCM12SD, 12" Dual-Bevel Glide Miter Saw	15	No	12	No	3800	14
700220	DeWALT® DWS780 12" Double Bevel Sliding Miter Saw & DWX726 Rolling Stand	15	Yes	12	Yes	3800	16
B246918	Makita® LS1219L, 12" Dual-Bevel Sliding Compound Miter Saw with Laser	15	Yes	12	Yes	3200	15
B1774957	Makita® LS1018 10" Dual Slide Compound Miter Saw	13	Yes	10	Yes	4300	12
B2836505	JET® JET 12 Dual Bevel Miter Saw JMS-12X	15	Yes	12	Yes	4200	14



B2136716



B2275928



501235



B2136712

STATIONARY AND PORTABLE TABLE SAWS

Stationary table saws feature cast iron cabinets and polished steel tables. Quick-release riving knife greatly reduces binding and kickback risk. Portable saws provide cutting precision for jobsites, workshops, etc. Most models include rack-and-pinion fence rails.

Model	Description	AMPS 115/230	Voltage	Type	RPM	Fence Style	Max Rip Size"
B2136716	Delta 36-L552 10 In. Type 2 UNISAW® 5HP Left Tilt W/52 In. BIESEMEYER® Fence System	17	230	Stationary	4300	Biesemeyer	52
B2136712	Delta 36-5100 10 In. Left Tilt Table Saw W/30 In. Right Rip, Cast Iron Wings	15/7.5	120/240	Stationary	3450	Biesmeyer	30
B2275928	Powermatic 2000B Table Saw - 5HP 3PH 230/460V 30" Rip W/Accu-Fence	13/6.5	115/230	Stationary	4500	Accu-Fence	30
501235	DeWALT® DWE7491RS 10" Jobsite Table Saw & Rolling Stand	15	120	Portable	4800	Telescoping	32.5
B1140906	Powermatic 1791001K Model PM1000 1-3/4HP 1-Phase 115/230V Table Saw W/ 52" Accu-Fence System	15/7.5	115/230	Stationary	4200	Accu-Fence	52



B243276



B2185821



535715

BAND & SCROLL SAWS

Our collection of band saws and scroll saws are designed to handle every cutting need. Choose from portable or stationary models in various sizes from the top name brands.

Model	Description	AMPS	Voltage	Type	SFPM or SPM
B2305538	JET 714400K JWBS-14SFX - 14" Steel Frame Bandsaw - 1.75 HP - 1 Ph - 115/230V	15/7.5	115/230	Stationary Band	3000
B503758	JET 710116K Model JWBS-14DXPRO 14" Deluxe Pro Bandsaw Kit	14/7	115/230	Stationary Band	1500/3000
535715	Powermatic PM2415B, 24" Bandsaw, 5HP 1PH 230V	22	230	Stationary Band	2500-4800
B2185821	Delta 40-694 20" Variable Speed Scroll Saw	1.3	120	Benchtop Scroll	400-1750
700177	DeWALT DCS374P2 20V MAX XR Li-Ion Brushless Deep Cut Band Saw Kit 2 Batteries 5.0Ah Charger Case	5.0Ah	20	Portable Band	0-490
B243276	Milwaukee® 6242-6 Compact Band Saw	7	120	Portable Band	200-360

PORTABLE TOOL STORAGE

- Top brands available from Kennedy, Proto, Global Industrial, Homak, & Sunex Tools
- Options in steel, plastic, or lightweight reinforced structural foam
- Machinists chests offer felt-lined drawers for safe keeping of measuring instruments & other delicate tools



B211675



B211566



B983200

Model	Description	Construction	W" x D" x H"
B211675	Kennedy™ 24" Professional Hand Carry Steel Tool Box	Steel	24 1/8 x 8 3/8 x 9 3/4
B211566	Kennedy™ 7-Drawer Machinists Chest	Steel	26 3/4 x 8 1/2 x 18
B983200	Stanley® 3-In-1 Mobile Tool Box	Plastic	18 1/2 x 11 x 25

TOOL CARTS

Allow stationary or convenient mobile storage, and feature swivel casters & large handles for easy maneuvering. Choose from leading brands including Homak, Sunex Tools, Global Industrial, & Extreme Tools.

Model	Description	W" x D" x H"
534155	Global Industrial™ 27" 2-Drawer Tool Cart With Sliding Top	27 3/4 x 14 1/2 x 32 3/4
B643115	Sunex Tools 27" 5-Drawer Tool Cart With Locking Type	30 x 16 x 40



B643115



534155



133730



133725

JOBSITE STORAGE

- Full offerings from top brands including Global Industrial, Knaack, Jobox, Better Built, and Greenlee
- Provide maximum security against theft of valuables 24/7 with heavy-duty hinges, recessed lock housings, and side housing reinforcements around the lock to resist pry-ins
- Choose from chests, cabinets, piano boxes, and data vaults

Model	Brand	Type	Capacity (Cu. Ft)	W" x D" x H"
133725	Global Industrial	Welder Box	4	30 x 16 x 12
B2143699	Knaack	Jobsite Chest	9	42 x 19 x 23 3/8
133722	Global Industrial	Jobsite Chest	12	42 x 20 x 24
133723	Global Industrial	Jobsite Chest	28	48 x 30 x 33
B2143669	Knaack	Piano Jobsite Box	47.8	60 x 30 x 46
133724	Global Industrial	Jobsite Cabinet, 2 Doors	52	60 x 24 x 61
133730	Global Industrial	Field Station/Office	125	64 x 43 x 80

TOOL CHESTS & ROLLER CABINETS

Constructed of heavy-duty reinforced steel with a durable powder coat finish. Cabinet top surfaces feature raised edges to retain contents. High-security locks secure all drawers, ball bearing slides provide smooth operation under heavy loads. Heavy-duty swivel casters & large handles make maneuvering easy. Choose from top brands like Kennedy, Proto, Homak, Global Industrial™, and Extreme Tools.



535489

Model	Description	W" x D" x H"
B211631	Kennedy™ 27" 7 Drawer Wrinkle Brown Roller Cabinet	27 x 18 x 35
410207	Global Industrial™ 42" 21 Drawer Black Roller Tool Cabinet & Chest Combo	42 3/8 x 18 x 60 3/8
535489	Global Industrial™ 26" 11 Drawer Red Roller Cabinet & Chest Combo	26 3/8 x 18 1/8 x 52 3/8
535366	Global Industrial™ 25 1/8" 6 Drawer Black Tool Chest	25 1/8 x 12 1/8 x 14 3/4



DIGITAL MICROMETERS & INDICATORS

- Choose from top brands including Mitutoyo, Starrett, Fowler, InSize, & Global Industrial
- Feature large LCD displays, auto on/off, carbide measuring surfaces, & fitted plastic storage cases

Model	Description	Max Measurement"	Max Measurement MM
B611563	Mitutoyo Digimatic 0-1"/25.4MM Digital Micrometer	1	25.4
534803	Global Industrial™ 0-1"/25.4MM Twin Force IP65 Digital Micrometer	1	25.4
B611465	Mitutoyo 0-.5"/0-12.7MM Digimatic Electronic Indicator W/ Flat Back	0.5	12.7



CALIPERS

- Choose from top brands Mitutoyo, Starrett, Fowler, InSize, and Global Industrial
- Digital models feature large LCD displays, auto on/off, and carbide measuring surfaces
- Ranges from 4" up to 6" (150 mm) maximum measurement
- Include fitted plastic storage cases

Model	Description
534250	Mitutoyo 500-196-30 Digimatic Stainless Steel Digital Caliper
534802	Global Industrial™ Absolute Origin IP54 Digital Caliper W/Factory Calibration
534164	Global Approved Precision Dial Caliper

THERMAL IMAGING CAMERAS & NON-CONTACT INFRARED THERMOMETERS

- Choose from top brands FLIR, Extech, Fluke, General Tools, and Milwaukee
- Offer portable, accurate, non-contact measurements in the palm of your hands
- Excellent for automotive, HVAC, IT, plumbing, and construction applications



Model	Description	Temp. Range ° F
B2280617	FLIR C5 Compact Thermal Imaging Inspection Camera W/WIFI	14 to 122
B249634	General Tools "Heat Seeker" Mid-Range Infrared Thermometer	-4 to 608



MEASURING TAPES & LASER DISTANCE METERS

- Choose from top brands Stanley, Lufkin, Milwaukee, Johnson Level, & Leica
- Tape Measures from 10' to 200'
- Laser Distance Meters to 330' & transmit dimensions to your Bluetooth-enabled device

Model	Description	Maximum Distance'
B983634	Stanley PowerLock® Classic Tape Measure	25
B454201	Leica DISTO™ Bluetooth 4.0 Laser Distance Meter	320



VICES

- Choose from top brands Wilton, Global Industrial, Yost, and Palmgren
- Options of swivel or stationary bases & jaw surface material
- Drill Press & Angular options for metalworking & woodworking applications

Model	Description	Jaw W" D"	Throat D"	Max. Opening"
534515	Global Industrial™ General Purpose Bench Vise W/Swivel Base	4	2¼	4
B2281690	Wilton "Bullet" Tradesman Vise	8	5	7¾
B503828	Wilton Drill Press Vise	4	1½	4½



B2400407

THE REBEL™ MULTI-PROCESS WELDERS BY ESAB

These true multi-process welders are ideal for applications that require MIG, gasless, and gas-shielded Flux-Cored wire, Stick, and TIG. Weighs just 53-pounds with an output rating of 235 A, it has the capability to weld the full range of .035 solid wire.

Model	Description
B2400407	EMP 235ic Multi-Process Welder, 120/230V, 250A, 15' Cable, Single Phase
B2400405	EMP 215ic Multi-Process Welder, 120/230V, 240A, 10' Cable, Single Phase



B2406192

THERMAL DYNAMICS CUTMASTER® 40

The perfect combination of end-user insight, advanced technology, and intelligent design, this cutter has the highest power-to-weight ratio in its class, as well as best-in-class cutting arc length.

Model	Description
B2406192	CUTMASTER 40 20' SL60 Plasma Cutting System, 110V/240V, 350A - 400A



B2400398

ELECTRODES & HOLDERS

- Electrodes conduct electricity to the base metal and act as filler material during arc welding
- Rod size and composition differ for applications and material to be welded
- Package quantities and additional specifications vary per model
- Holds an electrode and conducts electricity to it for arc welding
- Insulated handle protects user and helps them precisely guide the electrode
- Available from 1/4" to 7/32" holding size, connections and specifications vary per model

Model	Description
B2400331	Tweco -Tong A-732 Electrode Holder (300A, 2/0 MAX, thru 7/32) Copper Alloy, Clamshell
B2406176	ESAB - 7018-1 Prime 1/8"Dia x 14"D VacPac Low Hydrogen Electrodes, SMAW
B2400398	ESAB - Sureweld 6010 Mild Steel Stick Electrodes, Flux Coat, 1/8" Dia. x 14 x 5#VALP
B2400486	ESAB - Sureweld 6013 Mild Steel Stick Electrodes, Flux Coat, 1/8" Dia. x 14 x 5#VALP
B2400482	ESAB - Sureweld 7018 Low Hydrogen Stick Electrodes, Flux Coat, 5/32" Dia x 14" x 5#VALP
B2400424	ESAB - Atom Arc 7018 Acclaim, 1/8"Dia. x 14", 10# HSC, DCEP Polarity, Low Hydrogen Electrodes
B2406179	ESAB - WELD 70S-6 .035"Dia. MIG Welding Wire, 33# Wire Basket, GMAW, Mild Steel
B2400389	Tweco -350A Spray Master .045" - 1/16" Air Cooled MIG Gun -15' Cbl; Connector



B2400418

WELDING STARTUP KITS & ACCESSORIES

ESAB & Tweco brands are market leaders in electrodes and welding accessories.

Model	Description
B2400418	Victor -Journeyman EDGE 2.0, CGA 540/510, Cutting, Heating & Welding Outfit
B2400420	Victor - Performer; CGA 540/300 EDGE 2.0 Cutting, Heating and Welding Outfit, Acetylene
B2400401	ESAB - Sentinel A50 Variable Shade(9-13) Welding Helmet, Blk, 5 Arc, 3.93" x 2.36" View Area



B1222316



133708



700142

PNEUMATIC IMPACT WRENCHES

Used for automotive repair, large-scale construction projects, heavy equipment maintenance, and more. Impact wrenches provide high torque operation, operated via a compressed air system. Anvil, RPM, max torque, drive size, and air inlet vary per model.

Brand	Mfg. Part #	Style	Anvil	CFM	RPM/BPM	Max Torque Ft. lbs.	Model
3/8" DRIVE							
Global Industrial	G3431K	Pistol/Kit	Standard	2	7000	260	B2383975
Ingersoll Rand	2235TIMAX	Pistol	Standard	3	8500/1220	930	700142
Global Industrial	133706	Pistol	Standard	5.7	13000	400	133706
3/4" DRIVE							
Global Industrial	133708	Pistol	Standard	7.3	6000	1300	133708
1" DRIVE							
Global Industrial	133710	D-Handle	Extended	7.5	5500	2200	133710
Chicago Pneumatic	8941077826	D-Handle	Extended	10	5160/500	2140	B1222316



B2383975

COMPRESSED AIR MAKES THE WORK A BREEZE



B2383983

133716

B2383981

AIR GRINDERS AND SCALERS

Used for various professional grinding, surface preparation, or die maintenance applications. Grinders are lightweight, easy-to-use, and ideal for power finishing, cutting, or die maintenance applications. The configurations, CFM, RPM, and style vary per model.

Model	Brand	Grinder Type	CFM	RPM/BPM
B2383983	Global Industrial	4" Angle Grinder	4	25,000
B2383982	Global Industrial	Right Angle Die	4	22,000
B2383981	Global Industrial	Straight Die w/Bur Kit	4.5	7,000
133716	Global Industrial	Needle Scaler	4.5	4,800

AIR SANDERS

Lightweight, easy-to-use air sanders are used in a variety of sanding, polishing, and finishing applications. Comfort grip handles and trigger mechanisms offer ergonomic control and reduced user fatigue. Various styles available.

Model	Brand	Sander Type	CFM	RPM
32383970	Global Industrial	2" Disc	3.6	15,000
32383972	Global Industrial	Jitterbug	4	6,500
32383973	Global Industrial	Dual Action	5.3	10,000



B1222304

133711

B2383977

AIR DRILLS & SCREW DRIVERS

Air drills work at high speeds for efficient drilling in woodworking, metalworking, construction, and automotive applications. Lightweight composite housings and textured rubber handles provide comfort and reduced user fatigue. Chuck size, CFM, and RPM vary per model.

Model	Brand	Chuck Size"	CFM	RPM
B2383977	Global Industrial	3/8	6	1100
133711	Global Industrial	1/4	3.5	2100
B1222304	Chicago Pneumatic	1/2	6	800



32383973

32383970

32383971



B904610

B904611

AIRSPADE EXCAVATION TOOLS

AirSpades allow quick and easy excavation. Used in arboriculture, utility, construction, and industrial applications, they uncover underground objects, utility lines, or even sensitive tree roots without harm, and dig faster and more efficiently than conventional hand tools.

Model	Mfg. #	Description
702188	ASU4150G4	Utility AirSpade 4000 105 CFM with 4 ft. Barrel
B904610	HT107	AirSpade 2000 Arbor/Landscape Kit with 150 CFM Nozzle
702187	ASU4150KT	Utility AirSpade 4000 Kit with 150 CFM Nozzle
B904609	HT106	AirSpade 2000 Utility/Construction Kit with 150 CFM Nozzle
B904611	LT3000	AirSpade 3000 330 CFM with 55" Barrel



B2211963



B2211976

B2211945

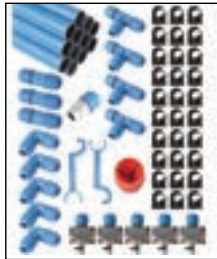

B2211950

COMPRESSED AIR PIPING KITS, TUBING KITS, & ACCESSORIES

These kits are used for automotive, industrial, manufacturing applications and more. Kits provide consistent airflow to air-powered tools including nail guns, staplers, pneumatic wrenches, and more. Corrosion-resistant materials. Units may be wall mounted.

PIPING AND TUBING KITS					
Model	Brand	Mfg. Part #	Description	Hose I.D."'	Hose Length'
B2211962	Maxline	M6026	Master Tubing Kit	½	100
B2211963	Maxline	M3800	Master Tubing Kit w/3 Outlets	½	100
B2211959	Maxline	M7500	Master Tubing Kit w/3 Outlets	¾	100
B2211957	Maxline	M6031	Master Tubing Kit	¾	300
B2211960	Maxline	M7580	Master Tubing Kit w/3 Outlets	¾	300
B2211950	Fastpipe	F28235	Master Piping Kit w/5 Outlets	1	235

PIPING AND TUBING KIT ACCESSORIES					
Model	Brand	Mfg. Part #	Description	Hose I.D."'	
B2211943	Maxline	M8064	Tubing Clamp - 10/pkg	½	
B2211945	Maxline	M8010	Tee Fitting	½	
B2211981	Maxline	M8003	Tubing x Male NPT Fitting	¾	
B2211978	Maxline	M8067	Elbow Fitting	¾	
B2211976	Fastpipe	F2002	Union Fitting	1	
B2211969	Fastpipe	F2003	Elbow Fitting	1	



B601898

WE CARRY A LARGE SELECTION OF TOOLS & INSTRUMENTS

ARROW PNEUMATICS IN-LINE DESICCANT DRYERS

Desiccant dryers are used for a variety of efficient drying in compressed air applications. They remove all traces of water vapor, oil vapor, and dirt from a compressed air system. Made of zinc and aluminum or plastic bowls for long lasting durability.



B601901

Model	Mfg. Part #	Description	PSI	Port Size NPT"	Micron Rating	Bowl Type
B601902	DFD-10	Mini In-line	125	¼	40	Plastic
B601899	D12-04	PneuMasterAir 1 Quart	250	½	40	Zinc & Aluminum
B601901	D7612	Economy StageAir 1 Qt.	200	½	40	Zinc & Aluminum
B601900	D12-04XL	Dryer/Filter	250	½	40	Zinc & Aluminum
B601908	D12-04XXL	Dryer/Filter	250	½	40	Zinc & Aluminum
B601897	C7612XL	StageAir	250	½	0.03	Zinc & Aluminum
B601898	C7612XXL	StageAir 1 Gal.	250	½	0.03	Zinc & Aluminum

REPLACEMENT DESICCANT SILICA GEL		
Model	Mfg. Part #	Description
B601903	34189	Arrow 1 Quart Replacement Desiccant Silica Gel - 6 Pk
B601904	34417	Arrow 1 Gallon Replacement Desiccant Silica Gel - 4 Pk



EXCLUSIVE BRANDS

TWO-STAGE AIR COMPRESSORS

Two-stage air compressors meet the high demands of maintenance shops, woodworking, production lines, car washes, commercial applications and more. Available in variety of sizes and power levels, with tank sizes from 60-240 gallons. Power levels from 5-30 HP.

Model	HP	Gal. Cap.	Volts/Phase
B2811234	5	80	230/1-Phase
B2811235	7.5	80	230/1-Phase
B2811236	10	80	230/1-Phase



B2811234



B2811235



B2811236



634164



B2192499

SINGLE-STAGE AIR COMPRESSORS

These compressors are a great value solution for air power and are commonly used in heavy DIY shops, automotive garages, and light commercial applications. Single-stage compressors are made with cast iron or aluminum pumps and steel tanks.

Model	Brand	HP	Volts/Phase	CFM	PSI	Gal. Cap.
634163	Ingersoll Rand Company	3	230/1-Phase	11.3	135	60
634164	Ingersoll Rand Company	5	230/1-Phase	18.1	135	60
B2192499	Porter Cable	3.5	230/1-Phase	11.5	135	60



B2190767



B686793

GAS POWERED FLEET AIR COMPRESSORS

Gas-powered air compressors are ideal for fleet service trucks, welding trucks, and remote jobsite locations where electrical power is limited or non-existent. Available in stationary or portable configurations to allow flexibility for the jobs at hand. Diesel engines also available.

Model	Brand	HP	Engine Brand	CFM	PSI	Gal. Cap.
B2190767	Emax	18	Honda	39	175	60
B686793	Ingersoll Rand	13	Honda	25	175	30
B686853	Ingersoll Rand	14	Kohler	24	175	30
B2117479	Puma	13	Honda	23	175	Tankless

CHECK YOUR SOUND LEVEL SAFETY

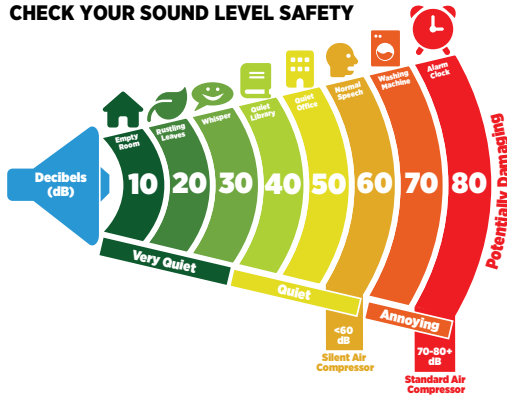

717620

133686



133682

QUIET & SILENT AIR COMPRESSORS

These air compressors are designed for low-noise operation while providing efficient pressurized air power. Sizes vary from small portables to large 2-stage 80-gallon industrial compressors. A-weighted decibels (dBAs) surpass current and future EPA requirements.

Model	Brand	Noise Output	Gal. Cap.	HP	CFM
717620	Emax	37 dBA	5	1.5	5.29
B2190723	Emax	<80 dBA	80	5	19
B2133773	California Air	60 dBA	2	2	3
133686	Global Industrial	58 dBA	80	10	38
133682	Global Industrial	55 dBA	80	7.5	31

ROTARY SCREW & SCROLL AIR COMPRESSORS

Air compressors provide high volumes of air with minimal noise, low vibration, and maximum efficiency. Designed using oil-injected pumps, these durable compressors feature a continuous duty cycle to provide the convenience of continuous non-surge air flow.

Model	HP	Volts/Phase
B2811238	7.5	230/1-Phase
B2811237	10	230/1-Phase
B2811233	5	230/1-Phase



B2811238



B686819

SHOP OUR FULL RANGE OF AIR COMPRESSORS

AIR DRYERS

Air dryers are a crucial component to a compressed air system. A highly cost-effective method for removing condensation from the system, they reduce corrosion and damage to tools, machines, and processes within the facility.



B2811239

Model	Brand	Description	CFM	Volts/Phase
B2811239	Global Industrial	Refrigerated Air Dryer	30	115/1-Phase
B686819	Ingersoll Rand	Non-Cycling Refrigerated Air Dryer	42	115/1-Phase
B686823	Ingersoll Rand	Non-Cycling Refrigerated Air Dryer	200	115/1-Phase
B686888	Ingersoll Rand	Non-Cycling High Temperature Refrigerated Air Dryer	15	115/1-Phase

MOTORS & POWER TRANSMISSION

178

BALDOR



HPB389975

BALDOR



HPB387897



HPB222066



HPB388826

FASCO



HPB186686

Century



HPB185982

Century



HPB185878

POWER YOUR BUSINESS WITH MOTORS FOR ALL TYPES OF DUTY

We offer a wide variety of motors from the top brands in the industry. Specific motor types include Premium-efficiency, Inverter-duty, Severe-duty, Farm-duty, Hazardous-rated, and more. Applications include pumps, fans, blowers, compressors, washdown, direct current, OEM equipment, close-coupled equipment, and more.



HPB466844



HPB466053

marathon



HPB869211



HPB2046573

LIGHTING & ELECTRICAL

179-181

EXCLUSIVE BRANDS



DOCK LIGHTS/ FANS

Designed to illuminate hard-to-reach loading and unloading areas, these high-lumen lamps use energy-efficient LED technology. Double-arm models offer superior durability and rigidity

Model	Description	Arm Reach"
423250	Dock Light, Multi Pivot, Yellow	40
501301	Gooseneck LED Dock Light w/27"	27
501636	LED Dock Light & 3-Speed Fan, 1800 Lumens	40

EXCLUSIVE BRANDS

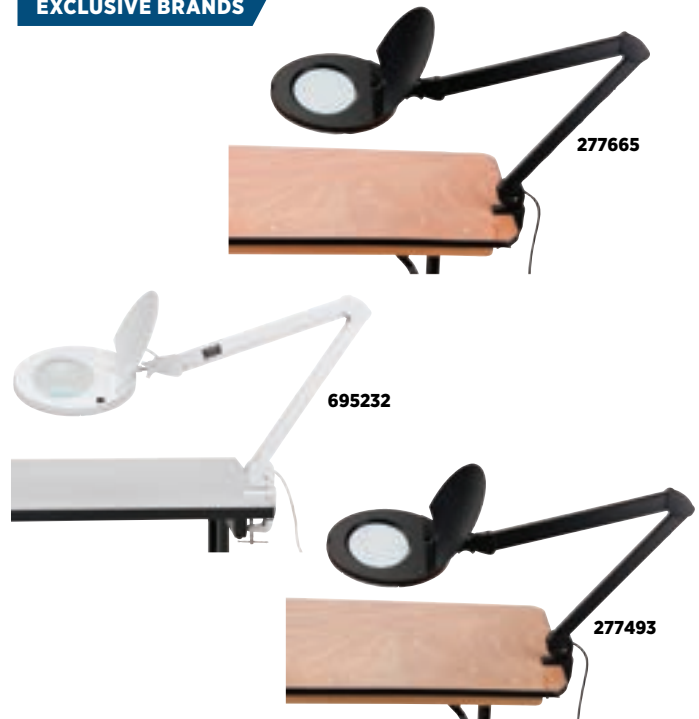

MAGNIFIER LIGHTS

Premium 2-in-1 lighting and magnification lamps feature metal G-clamps for desktop use. Comes with 5" round glass lens and a optional hinged, dust-proof cover. Uses 80 ultra-efficient SMD LEDs which offer glare-free light. Adjustable swing arm is made of metal and includes an arm cover which reduces possibility of hand pinching or injury.

Model	Description	Diopter	Color
277665	LED Magnifying Lamp with dust-proof cover	8	Black
695232	LED Magnifying Lamp with dust-proof cover	3	White
277493	LED Magnifying Lamp with dust-proof cover	5	Black

COMMERCIAL LED HIGH BAY LED LIGHTING

Ideal for one-for-one replacement of conventional lighting systems such as HID or fluorescent. Mounting heights ranging from 10' to 40'. Available with a variety of wattages, lumens, color temperatures, and shapes

Model	Mfg. Part No.	CCT	Watts	Lumens	Shape
812421	CLU11-150WRD1-BK50	5000	150	19500	Round
812435	CLU11-240WRD1-BK50	5000	240	32400	Round



EXCLUSIVE BRANDS



500881

500890

500798

POWER STRIPS

- Durable power strips with metal or plastic housings
- Wide range of outlet quantities and lengths

Model	Strip Length	Outlets	Amps
500890	48"	18	15
500881	12"	6	15
500798	48"	12	15

EXCLUSIVE BRANDS



501617

500797

500796

SURGE PROTECTION STRIPS

Durable power strips with surge protection from 90 to 2000 Joules

Model	Strip Length	Outlets	Amps
501617	12"	6	15
500797	12"	8	15
500796	15"	6	15

MORE LIGHTING & ELECTRICAL

EXCLUSIVE BRANDS

EXTENSION & REPLACEMENT CORDS

- Extension cords for indoor/ outdoor use
- Power cords have premium PVC exterior
- Suitable for use with appliances
- Wide variety of lengths, wire gauges, amps



500794

B790644



EXTENSION CORDS

Model	Type	RCPT	Length'	Amps	Gauge
500794	FL-101L Outdoor Extension Cord w/Lit Plug, 125V, 1625W 16AWG/3C	1	50	13	16
500791	FL-101 Outdoor Extension Cord, 125V, 1625W 14AWG/3C	1	100	13	14

INDUSTRIAL CORD REELS

- Keep electrical cords safely protected, organized, and off the floor
- Outlet cord reels range from 10-20 amps. Cord lengths range from 25-100 feet
- Wire gauges 16- to 10-gauge. Choose from 1-4 receptacles

OUTLETS						
Model	Brand	Description	Includes Cord	Length'	Amps	Gauge
B790533	Bayco	Quad Tap, Retractable Reel Extension Cord	Yes	50	15	12
B250727	Reelcraft	Single Outlet Heavy Duty Power Cord Reel	Yes	45	20	12
B790644	Bayco	Triple Tap, Retractable Reel Extension Cord	Yes	30	13	14

B250727





716173



716174



501312

PORTABLE GENERATORS

Portable generators provide critical backup power in case of emergencies, or when power is not available. Suitable for home or commercial use. Choose from a wide variety of brands and outputs. All generator sales are final.

Model	Approved	Outlets	Start Type	Rated Watts	Mfg. Part #	Brand
716174	Carb/CSA	5	Electric/Recoil	6500	GG7200	Global
716173	Carb/CSA	5	Electric/Recoil	3000	GG3300	Global
501312	EPA, CARB	6	Electric/Recoil	8000	XP10000EH	DuroMax

PORTABLE POWER SYSTEMS

Provide portable AC power to devices such as laptops, printers, computers, and other electronics. These compact units are also capable of powering scales and testers while eliminating the need for hazardous extension cords or costly cable drops. Rechargeable, Includes side grip handles for easy transport.

Model	Description	Amp Hour	Power
436980	Portable Power System	40	500W
436981	Portable Power System	1000	1000W



436980



436981



500874



500781



500780

LED SIGNS & LIGHTING

Combo sign/light units illuminate the path of egress and meet Life Safety Code NFPA 101. Emergency lighting units provide a minimum of 90 minutes of light during power outages. Universal-mount exit signs have a rated life of 25-years. Maintenance-free ni-cad batteries.

Model	Description
500781	Combo LED Emergency Exit Sign- Red
500780	2 LED Round Heads Emergency Light w/Adjustable Optics
500874	LED Exit Sign Red w/Battery Backup



670615

CABLE PROTECTORS

Global Industrial™ Cable Protectors offer protection for wires, cables, or hose lines in high-traffic facilities. Use it on level surfaces where heavy-loaded pallet jack trucks, forklifts, and similar vehicles navigate the area. Ideal for protecting power lines, data lines, and various cables.

Model	Description	Capacity
670615	2-Channel Industrial Cable Protector	16,000 lbs.
670616	2-Channel Heavy-Duty Cable Protector	24,000 lbs.
670618	3-Channel Industrial Cable Protector	22,000 lbs.
670621	5-Channel Industrial Cable Protector	22,000 lbs.

MACHINING

182-185



B2319549

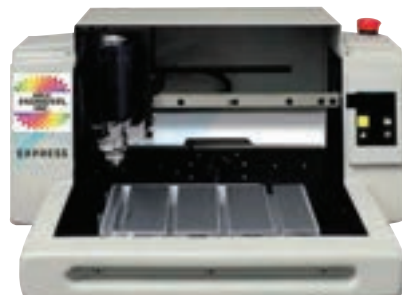

B3112804

ENGRAVERS

Customize and personalize metal products with these high-speed engraving machines or metal impact printer. Perfect for gift personalization, trophy customization, and more. Compact desktop design and easy-to-operate with software included.

Model	Description	Max. Work Area
B2319549	Roland DE-3 Desktop Rotary Engraver	12" x 9"
B3112804	Vision S5 Express Engraver	6" X 8"
B3055643	Baileigh Industrial Desktop CNC Engraver DEM-0906	9" x 6"
B3055679	Baileigh Industrial Desktop CNC Engraver DEM-1717	17" x 17"
B3112803	Roland GS-24 Desktop Vinyl Cutter	



B2802702



B1966848



B2731069



B2731067

3D PRINTERS

Produce prototypes on-demand and make changes whenever you like. 3D printers are perfect for designers, engineers, and inventors by providing quick turn-around time to win business where speed to market is key. Choose from four models.

Model	Description	Max. Print Width	Max. Print Height	Max. Print Depth
B2731067	MakerBot® Method X 3D Printer	190.5 mm	196.85 mm	190.5 mm
B2731068	MakerBot® Method 3D Printer	190.5 mm	196.85 mm	190.5 mm
B2731069	MakerBot® Replicator+ 3D Printer	294.64 mm	165.1 mm	193.04 mm
B2731071	MakerBot® Sketch Kit 3D Printer	149.86 mm	149.86 mm	149.86 mm
B1966848	3D Printer, Evolution Gen 2 Pro, Transparent Casing	230 mm	205 mm	230 mm
B1966849	3D Printer, Creator Gen 2 Pro, Transparent Casing	---	---	---
B1966850	3D Printer, Creator Gen 2 Pro, Black Casing	347.11 mm	347.11 mm	355.6 mm
B2802702	MakerBot® Method 3D Printer - Carbon Fiber Edition	190.5 mm	196.8 5mm	190.5 mm



B3055604

B3055724



B3055564



B3055691



BAILEIGH INDUSTRIAL® METAL-WORKING EQUIPMENT

Equip your shop with these sturdy metal folding, shearing, and notching machines. Shop presses are used for metal pressing or fabrication applications.

Model	Description	Type
B3055787	Vice Mounted Hole Saw Tube and Pipe Notcher, 2.5" OD, 2 Slotted Mounting Rails	Pipe Notchers
B3055604	Tube Bender, 110V, RDB-175	Pipe/Tube Benders
B3055651	Tube Bender, Single Phase, 220V, RDB-250	Pipe/Tube Benders
B3055724	½" Round Pipe Rolls, Single Phase, 220V, R-M40	Roll Benders
B3055691	Foot Stomp Shear, 52" Length, 16 Gauge Mild Steel Capacity	Shears
B3055564	Magnetic Sheet Metal Brake, Single Phase, 220V, BB-4816M	Sheet Metal Break
B3055637	20 Ton Air/Hand Operated H-Frame Press, 7½" Stoke, CE Approved	Shop Presses
B3055673	75 Ton Air/Hand Operated H-Frame Press, 9¾" Stoke, CE Approved	Shop Presses



B0231116

B0503591



B2220174



JET® AND EDWARDS® METAL-WORKING EQUIPMENT

These industrial machines are designed for heavy-duty use. Choose from standing floor models or hydraulic drill presses, variable-speed milling machines, horizontal band saws with large handwheel, geared-head lathes, and open-tooling workstations.

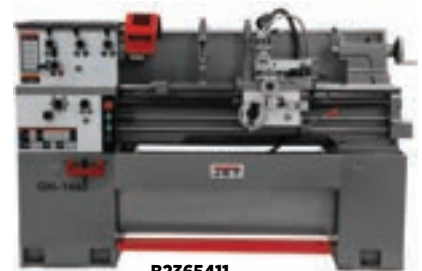

B2365411

Model	Description	Type
B0230730	Jet 354400 J-2500 15 Floor Model Drill Press, 115V, 1-Phase	Drill Presses
B0231116	Jet 690107 JTM-4VS Milling Machine W/Acu-Rite 200S DRO W/X-Axis Powerfeed, 3 HP	Vertical Milling Machines
B0503591	Jet 414468 HBS-916W 9 X 16 Horizontal bandsaw, 115/230V, 1-Phase	Horizontal Band Saws
B2365411	Jet 323374 GH-1440-1 With ACU-RITE 203 DRO	Bench Lathes
B2220174	Edwards 55 Ton Ironworker - 1 Phase, 230V w/ Hydraulic Accessory Pack - IW55-1P230-AC500	Ironworkers



HEAVY-DUTY JOBS REQUIRE INDUSTRIAL-STRENGTH TOOLS.



B231028



JET has provided the industrial marketplace with quality, innovation, and service for more than 60 years. Fueled by innovative product development, JET continues to establish itself as a full-line industrial tool brand.

B241865



WILTON has been making industrial work-holding equipment and striking tools for more than 80 years. It has painstakingly built a reputation for quality, durability, and reliability.

B3055700



Founded in 1999, Baileigh markets, manufactures, and distributes over 500 metalworking and woodworking products sold throughout the US & Europe. Through its wholly-owned subsidiary, RMD, Baileigh designs and manufactures "Made-in-the USA" Baileigh-branded metalworking machinery.

B1140904



Since 1921, Powermatic has been committed to making durable, quality tools for the master woodworker. With innovative products for both commercial and home hobbyists' shops.

EXCLUSIVE BRANDS

PORTABLE PRESSURE AND BLAST CABINETS

These cabinets are designed to remove unwanted layers of rust and discoloration from metals, wood, and plastic. For automotive rebuilding, aviation maintenance, and more. Most models feature bright lighting, a wide-view window, and dust collectors for better visibility.

Model #	Type	CFM	PSI	Capacity	Blast Type
320775	Foot Operated	9-12	90-125	420 Liter	Siphon
320776	Trigger Operated	6-20	65-125	5 Gallon	Pressure
320777	Trigger Operated	6-20	65-125	20 Gallon	Siphon



320775



320776



320777

BLAST MEDIA

When sandblasting will damage the surface you need stripped and cleaned, choose different blast media to get the job done without causing unwanted damage to the substrate material. Check your blast equipment's specifications for compatible media.

Model	Grit	Material	Qty. Lbs.
B2247230	20-30	Plastic	25
B2312096	60-100	Glass	50
B782601	60-100	Glass	50
B2247123	50	Bicarbonate of Soda	20

SMOOTH OUT THE ROUGH SPOTS WITH OUR ABRASIVES

CUT-OFF WHEELS

Ideal for aluminum, plastic, sheet metal, stainless steel and more, cut-off wheels make clean cuts and notches with the ability to describe arcs and curves for precise cuts and minimal surface cleanup.

Model	Grade	Grit	Dia.
B2255438	Coarse	36	5"
B481774	Medium	60	6"
B2232912	Extra Coarse	36	3"
B2218913	Medium	60	4.5"
B2225268	Medium	60	4.5"
B481735	Medium	60	4.5"



QUICK-CHANGE DISCS

Durable 3M Quick Change Discs feature open-web material that runs cool and resists loading. Coating-removal discs provide more surface area than wire brushes. A quick TR attachment and removal feature provides easy disc change-out.

Model	Abrasive	Grade	Grit	Dia.	Pkg. Qty.
B296696	Aluminum Oxide	Medium	80	2"	50
B296690	Aluminum Oxide	Fine	P120	2"	50
B296691	Aluminum Oxide	Medium	60	2"	50
B296463	Aluminum Oxide	Extra Coarse	36	2"	50
B1483472	Ceramic	Medium	80	2"	50
B297783	Aluminum Oxide	Very Fine	VFN	2"	50
B297948	Aluminum Oxide	Coarse	CRS	2"	50
B297806	Aluminum Oxide	Medium	MED	2"	50
B297782	Aluminum Oxide	Very Fine	VFN	3"	25
B297779	Aluminum Oxide	Medium	MED	3"	25



FASTENERS & HARDWARE

186-187



320742



B2186255



B2213335



B361647



B2213479



B2213556



B701312

ANCHOR FASTENERS

Anchor fasteners are used to connect structural elements of base material to drywall, metals, masonry, and concrete in buildings and structures. Global Industrial has a wide range of fasteners to solve any construction issue.



B228504



B831570



B831467



B553088



B831823



B2249915



B2246252

MACHINE LEVELING MOUNTS

Also known as a leveling foot or leveling pad, a leveling mount is a mechanical device that's used to level the object or machine on which it's installed. They feature an adjustable height, allowing users to control the height at which the machine or object rests off the floor.



804072



B1798408



320755



B1798457



B2157530



B2157382



B2258832

MAGNETS

Magnetic hooks and carabiners provide a handy place to hang lights, keys, ropes, chains, power tools and more. Choose from various materials; 20- to 90-lb. pull capacity.



B2183493



B2215103



B2215087



B2183542



B2184555



B2183678



B2184260

TAMPER-PROOF FASTENERS & TOOLS

Tamper-proof security cap screws provide an added level of security with a drive design that prevents removal with ordinary screwdrivers. Tamper-proof security cap screws are ideal for repair work or construction projects. Engineered for a high degree of tamper-resistance and offering positive-engaging, high-torque transmission while resisting cam-out and tool wear. Matching driver bit required for installation and removal. Additional specifications vary per model.

Bits for tamper-proof security fasteners allow ergonomic fastener handling and control for repair, construction, automotive, and more. Matching driver bits for Phillips pin-head, 6-lobe pin-head, socket pin-in-hex, tri-wing, opsit & Snake Eyes screws. Bits used for removable spanner nuts are also available. Drive types are Phillips, socket, spanner, spanner nut, torx, tri-wing, and trilobular. Bits are available in both imperial and metric sizes.



HPB2170190

SHOP FOR MORE FASTENER ASSORTMENTS

- Washer assortments**
- Maintenance kits**
- Blind rivet assortments**
- Cotter pin assortments**
- Set screw assortments**
- Key, pin, & grease fitting assortments**
- Sheet metal screw assortments**

- Anchor assortments**
- Carriage & lag bolt assortments**
- Nut & washer assortments**
- Nut assortments**
- Woodruff key assortments**
- Self-drilling & self-tapping assortments**

BUILDING SUPPLIES

188

EXCLUSIVE BRANDS

GALVANIZED POWDER COAT STEEL ROOF HATCH

14-gauge steel access hatch provides roof access for any building. The door seal, base insulation, and wool insulation ensure indoor climate control and reduced heating costs. Rust-resistant finish. The heavy-duty automatic lock arm secures the hatch. Comes in 2 sizes. 30x36" and 24x36".



713150

POWDER COAT STEEL ROOF HATCH SAFETY EXTENSION HANDLE

Mounts to roof hatches allowing easy egress and ingress via the safety ladder while ensuring a secure grip. Heavy-duty galvanized steel is fully welded for strength and durability. The yellow finish offers high visibility while preventing rust and oxidation.



713157

GALVANIZED STEEL SAFETY RAILING FOR 24 x 36" & 30 x 36" ROOF HATCHES

Telescopic safety railing has a magnetic-close swing gate. Yellow finish offers high visibility while preventing rust and oxidation. Meets OSHA 1910.28 requirement for safe egress and ingress through rooftop hatch openings and OSHA 1910.29 fall protection system requirements.



713159

LADDER SAFETY POST

Supports fixed-ladders under access doors and manhole covers. Bracket automatically locks in the fully-raised position for stability. Easy-release lever. Supports heavy-duty ladders. High-visibility yellow finish prevents rust and oxidation. Accommodates multiple ladder types.

713158



MULTI-PURPOSE METAL ACCESS PANEL

Designed for walls or ceilings, this 24" x 24" panel can be painted to match the surrounding walls, permitting unobtrusive, secure key-lock access for inspection or maintenance purposes. Frame and door are 16-gauge steel with a 1" wall flange, concealed hinge, and an included flush cam-lock.



602332

ALUMINUM DOOR CLOSER

Ideal for internal and external use on public or commercial buildings, closers meet ADA requirements for opening force. It can be adjusted to control the opening and closing force and speed. Backcheck cushions prevent uncontrolled opening of the door. UL 10C fire rating; ANSI/BHMA A156.4 certified.



713153

VEHICLE MAINTENANCE

189-190

B2060374



B2060377

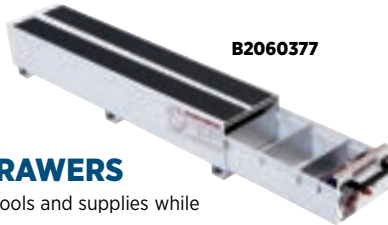

TRUCK BOXES & DRAWERS

- Provide easy access to large tools and supplies while minimizing footprint
- Weatherproof seals and tamper-resistant locks
- Corrosion-resistant powder coat finish

STEEL TRUCK DRAWERS

Model	Type	Qty. Dividers	Cap. Cu. Ft.	L" x W" x H"
B2060377	1 Compartment	6	5.2	48¾ x 10¾ x 9
B2060351	2 Compartment	12	8.3	48¾ x 20¾ x 9
B2060376	2 Compartment	6	11.9	48¾ x 30½ x 9

STEEL TRUCK BOXES

Model	Type	Cap. Cu. Ft.	L" x W" x H"	Construction
B652631	Underbed	6.75	18 x 18 x 36	Steel
B2060374	Side	15.2	90¼ x 16¼ x 18	Aluminum



WEATHER GUARD VAN STORAGE

- Allows convenient equipment access, organization, and storage
- Units accommodate compact, midsize, full-size, and other vehicle capacities
- Drop-down ladder racks, wire spool holders, parts cabinets, roof racks, and more available
- Aluminum, plastic, and steel options—choose the right construction for your needs

Model	Description	Construction
B2097040	EZ-Glide Drop Down Ladder Rack	Aluminum
B2096983	EZ-Cube 3 Shelf Unit - 42" x 42" x 14"	Steel
B2096947	Wire Spool Holder	Steel
B2097070	Three Hook Cord Tool Holder	Steel
B2096886	Locking 4 Drawer Cabinet - 24" x 16" x 14"	Steel

SERVICE JACKS & STANDS

- Bottle jack features cleated steel lifting saddle for load gripping power
- Floor jacks include built-in safety valve for overload protection
- Machined, polished cylinders provide nonabrasive, leak-free performance



B1145083

Model	Description	Cap. Ton	Low H"	Max H"
B1033938	Sunex Jack Stands	10	28	46½
B1145225	Pro-Lift Bottle Jack	2	7⅞	13⅞
B1145072	Pro-Lift Low Profile Jack	2	3½	14
B1145083	Hein-Werner Jack Stands	3	12	19
B1145156	Omega Crane Jack	8	24½	43¾
B1580045	Torin Scissor Jack	1.5	3¾	15½

B638669



B2222435



OIL DRAINS & PANS

Oil drains & pans allow mechanics and DIY-ers to quickly and easily change fluids in vehicles as part of regular maintenance cycles or at the end of the season for long-term equipment storage. When finished, the oil can be correctly disposed.

Model	Type	Gal. Cap.	Construction
B2222435	Self Evacuating Oil Drain Tank	18	Steel
B592246	Low Profile Portable Oil Drain Tank	17	Steel
Model	Type	Gal. Cap.	Material
B638669	Oil Drain Pan w/ Handles	4	Plastic
B638665	Drip Tray	2	Plastic

B2078435

B2264527



PORTABLE JUMP STARTERS

- Lithium jump starters provide an efficient and portable power solution
- USB ports support small electronic devices
- Safety technology ensures spark-proof connections and reverse polarity protection

Model	Brand	Description	Volts	Amps
B2078433	NOCO	Lithium Jump Starter W/LED Flashlight	12	1000
B2078435	NOCO	Lithium Jump Starter W/LED Flashlight	12	2000
B2078436	NOCO	Lithium Jump Starter W/LED Flashlight	12	4000
B2264527	DSR Proseries	Professional Jump Starter	12	2000

ENGINE & TRANSMISSION CRANES, JACKS, AND STANDS

- Cranes, jacks, and stands permit the ergonomic removal, mobility, and installation of heavy-duty equipment and tools
- Made of heavy-gauge welded square tubular steel for added strength and durability
- Hydraulic system features a patented bypass mechanism designed to prevent internal damage
- Handle release-pedal ensures user safety while lowering loads

Model	Description	Capacity
B2428219	American Forge & Foundry Engine Crane	6,000 lbs.
B1145163	Omega Folding Engine Stand	1250 lbs.
B1145187	Omega Engine Crane	2 Ton
B1145172	Omega Telescopic Transmission Jack	½ Ton
B1145181	Omega Transmission Floor Style Jack	1 Ton



TOWING PRODUCTS & ACCESSORIES

- Available in a variety of sizes and styles in a range of weight capacities
- Available in chrome or black powder coat finish, drops ranging from 2" to 6" and capacities up to 20,000 lbs

HITCH MOUNTS					
Model	Type	Size"	L"	Pin Hole"	M.G.T.W
B2276384	Double-Ball Hitch	2, 2 ³ / ₁₆	9 ³ / ₈	5/8	7,500/10,000
B2276383	Tri-Ball Hitch w/ Pintle Hook	1 ⁷ / ₈ , 2, 2 ³ / ₁₆	12 ¹ / ₂	5/8	6,W/7,500/10,000

HITCH BALLS				
Model	Type	Size"	Shank L"	M.G.T.W
B2276220	Black Hitch Ball	2 ³ / ₁₆	1 ¹ / ₂	30,000



TIRE CHAINS
B440693



SHOP OUR COMPLETE ASSORTMENT OF TIRE & WHEEL PRODUCTS

DOUBLE-WALL USED-OIL STORAGE TANKS

- Made from 10-gauge steel with powder coat finish for long-lasting durability
- UL-142 approved for safe flammable liquid storage in vehicle fleet maintenance operations
- Safety decals also included to meet OSHA standards

B2082058	120
B2082059	185
B2082060	240
B2082061	500



B2082058

WORKBENCHES & SHOP DESKS

191-198

WORK WELL WITH THE PERFECT WORKBENCH

Our modular workbench collections let you design for your specific job needs and space. With a wide selection of sizes, surfaces, storage spaces, and accessories, you'll have the ideal workbench for the tasks at hand.

CHOOSE YOUR CONFIGURATION

- 1 Choose your base style and size**
from our sturdy steel leg and pedestal designs, mobile, adjustable, or fixed / **Pages 192**
- 2 Choose your top and edge**
from 10+ wood, plastic, or metal options / **Page 192-193**
- 3 Choose your accessories**
Lights, drawers, shelves, panels, bins, and more! / **Page 194**



START CONFIGURING YOUR CUSTOM WORKBENCH



607268BL
5000 lb. Capacity

Bench Legs Include Foot Plates And Glides



607267BBLA

Bench with Pre-Wired Power Apron



1. THE IDEAL BASE IS THE PERFECT FOUNDATION

HEAVY-DUTY PRODUCTION WORKBENCHES

- Built to last with 2" square, 14-gauge tubular steel
- Height adjustable at 2" increments from 30" to 42"H
- Choose the power apron option for easy electrical connections
- Extra-strong full-perimeter channel frame for up to a 5,000 lb. capacity
- Choose from our wide variety of top surfaces and sizes
- Available in Blue or Tan frame



253977WBBL

493534BL



MOBILE HEAVY-DUTY PRODUCTION WORKBENCHES

- Easily roll your workbench on phenolic swivel casters with brakes
- Built to last with 2" square, 14-gauge tubular steel
- Up to 2000 lb. capacity, fixed height of 36"
- Choose the power apron option for easy electrical connections
- 15"D lower shelf with backstop for added storage space
- Choose from our wide variety of top surfaces and sizes
- Available in Blue or Tan frame

2. CHOOSE A TOP THAT FITS THE JOB



15/8" Plastic Square Edge



15/8" Plastic Safety Edge

SUPER-STRONG, SMOOTH, & EASY TO CLEAN



1 3/4" Maple Square Edge



1 3/4" Maple Safety Edge

MULTI-PURPOSE, NONCONDUCTIVE



1" Phenolic Safety Edge

CHEMICAL- & IMPACT-RESISTANT

ADJUSTABLE-HEIGHT C-CHANNEL LEG WORKBENCHES

- Steel C-channel height-adjustable legs adjust from 29½" to 35½"H
- Up to 2,000 lb. capacity
- Legs feature two knockouts for wired outlets or optional plug-in outlet
- Base plates allow for floor anchoring
- Choose from our wide variety of top surfaces and sizes
- Available in Gray and Black



MOBILE ADJUSTABLE-HEIGHT C-CHANNEL LEG WORKBENCHES

- Mobilize your adjustable C-channel workbench
- Caster kit includes two fixed and two locking swivel casters with 5" wheels for easy mobility
- 800 lb. capacity



FIXED-HEIGHT FLARED-LEG & PEDESTAL WORKBENCHES

- Mix and match fixed-height legs and/or pedestal bases
- Flared fixed-leg benches have up to 2,000 lb. capacity
- Legs feature two knockouts for wired outlets or optional plug-in outlet
- Various cabinet and drawer pedestal options
- Choose from our wide variety of top surfaces and sizes



Need a sturdy top that's ideal for you? Look no further. Our modular workbenches are available with a wide variety of surfaces to fit your needs and budget.



1 " ESD Square Edge

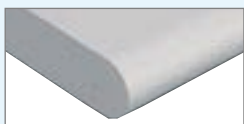

1 " ESD Safety Edge

ANTI-STATIC; PROTECTS SENSITIVE ELECTRONIC CIRCUITS



1 " Shop Top Square Edge



1 " Shop Top Safety Edge

DURABLE, BUDGET-FRIENDLY

Choose your accessories on the next page →

3. ADD-ON ACCESSORIES THAT WORK FOR YOU



606940

STEEL UPRIGHT KITS

- Add vertical accessories and storage space with this pair of 48" H uprights
- Sturdy steel construction with pre-drilled mounting holes designed to pair with other optional workbench accessories



319405

LED LIGHT KITS

- Provides direct overhead lighting
- Cantilever brackets are height-adjustable at 2" increments
- Includes two 35W, 5000-hour, non-replaceable LED lights, 120V
- Upright kit (sold separately) required for installation



412436

STEEL PACKING ACCESSORIES

- Customize your bench for packing by adding a Lower Steel Shelf and Upper Packing Kit
- Lower Shelf Kit is 31" D with 4 removable carton dividers and a 5" H storage shelf
- Upper Packing Kit includes a pair of 48" H uprights, two 12" D shelves, 6 adjustable dividers, bin rail, and reel holder

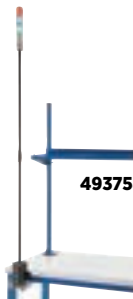

493758

WORKBENCH LED STACK LIGHT

- Highly visible LED tower provides easy visibility of production status
- Green, yellow, red lights used to clearly denote the workstation's current status
- Mounts to the workbench without occupying additional space
- Ideal for streamlining productivity in production processes



254754B

STEEL POWER RISERS

- Pre-wired, ready to use
- Six outlets with circuit breaker & pilot light
- Includes removable 9 1/2' cord and plug
- Offers a power supply of 15amp, 115V



606943

BIN RAILS

- A must for organizing small parts
- Upright Kit (sold separately) required



249296CBL

STEEL POWERED UPPER SHELVES

- Easily attaches using Included bracket, provides additional overhead storage
- 3 duplex outlets with circuit Breaker, pilot light, removable 12' cord and plug, 15amp, 115V
- Provides power for electrical equipment
- Rear lip helps retain contents
- Upright Kit (sold separately) required



606951

STEEL LOWER SHELVES

- Use for storage or as a footrest
- 2 1/2" backstop keeps item on shelf



606957TN

STEEL DRAWERS

- Can be mounted on either side of the workbench
- Provide lockable storage for valuable tools
- Install multiples for various drawer combinations
- 17 1/4" W x 20" D and either 6" or 12" H,
- Available colors: Gray, Blue, Tan

OR CHOOSE ONE OF OUR PRE-CONFIGURED WORKBENCHES



244186B



319344BL

HEAVY-DUTY PRE-CONFIGURED PRODUCTION WORKBENCHES

- Built to last with 2" square, 14-gauge tubular steel with up to a 5,000 lb. capacity
- Height adjustable at 2" increments from 30" to 42"H
- Includes lower shelf, two drawers, bin rail, pegboard, shelf, and LED light
- Choose between different bench tops, sizes, and panels.
- Available in Blue or Tan frame

MODEL	W" x D"	Top Material	Type
319302BL	48 x 30	Shop Top	Safety Edge
319319BL	60 x 30	Stainless Steel	Square Edge
319162	60 x 30	Plastic Laminate	Square Edge
319329BL	72 x 30	Maple	Square Edge
319336TN	72 x 30	Phenolic	Safety Edge
319344BL	72 x 36	ESD	Safety Edge



412473AB

PACKING WORKBENCHES

- Designed to make packing and shipping easy
- Some versions include both the Lower Shelf Kit with dividers and the Upper Packing Kit.
- Freestanding or mobile options
- Heavy-duty 14-gauge steel
- Stationary version has adjustable legs from 30" to 42"H, 5,000 lb. capacity
- Mobile wheeled option includes locking casters, is 36"H, 2,000 lb. capacity
- Pre-wired power apron options include 1 USB Type A/C and 2 duplex outlets

Model	W" x D"	Bench Top	Edge Type	Design
244182	72 x 30	Plastic Laminate	Safety	Stationary
244180	72 x 30	Plastic Laminate	Square	Stationary
B2336390	72 x 30	ESD	Safety	Stationary
244186B	72 x 30	Maple	Safety	Stationary
412445	72 x 36	Maple	Square	Stationary
412473AB	72 x 36	ESD	Square	Mobile



601425ABK

Available in Gray or Black

WORKBENCHES

- Steel C-channel height-adjustable legs adjust from 29½" to 35½"H
- Legs offer double electrical duplex knockout holes for duplex outlet or plug-in outlet
- Includes steel drawer and backstop on bench surface
- Riser shelf version offers extra storage space
- Choice of laminate, maple, shop, ESD, phenolic, or stainless steel tops

Model	W" x D"	Bench Top	Style
249521	60 x 30	Maple	Back Stops, Drawer & Riser
601425ABK	72 x 30	Plastic Laminate	Back Stops, Drawer



TRESTON MAKES WORKBENCHES THAT WORK WITH YOU, NOT AGAINST YOU.



CUSTOMIZE YOUR BENCH TO FIT YOUR NEEDS.



B2336923



B2336923

Workbenches shown with optional Accessories sold separately.

TRESTON CONCEPT MANUAL WORKBENCH WITH LAMINATE SQUARE EDGE TOP

- This 60" x 30" concept manual C-leg workbench comes with laminate top
- Maximum load capacity of 1100 lbs.
- Height is adjustable from 26³/₈" to 43⁵/₁₆"
- Workbench can be equipped with M60 single bay or double bay upright modules and accessories
- Limited 5 year warranty

TRESTON CORNERSTONE WORKBENCH WITH ESD LAMINATE SAFETY EDGE TOP

- This 48" x 30" cornerstone workbench comes with an ESD laminate top
- Maximum load capacity of 2000 lbs.
- Height is adjustable from 27-9/16" to 37-5/8"
- Workbench can be equipped with M60 single bay or double bay upright modules and accessories
- Limited 5 year warranty



606761

HEAVY-DUTY EXTRA-LONG ASSEMBLY WORKBENCHES

- Accommodates large packing, assembly, or heavy-duty operations
- Space-efficient, easily transportable design features folding legs
- Telescoping tubular steel legs for easy height adjustability
- Support brackets for rigidity and stability
- Lower shelf for added storage
- 13-gauge steel top that cushions shocks and heavy pounding

MODEL	W" x D"	BENCH TOP
606761	96 x 34	Steel
606762	96 x 48	Steel
606764	120 x 34	Steel
606765	120 x 48	Steel
606770	96 x 34	Hardboard
606771	96 x 48	Hardboard
606773	120 x 34	Hardboard
606774	120 x 48	Hardboard



253756



253755

HEAVY-DUTY MOBILE SERVICE BENCHES

- All-welded heavy-duty steel with a 2000 lb. capacity
- 1" high 3-sided lip edge with backstop
- Chrome-plated locking handles
- 5" x 2" non-marring phenolic casters; 2 rigid, 2 swivel

MODEL	W" x D" x H"
253756	48 x 26 x 34
253755	36 x 26 x 34



493730GY

L-SHAPED ADJUSTABLE HEIGHT WORKBENCH

- Assembles in a left or right-hand configuration
- Table holds up to 1,000 lbs.
- Bottom shelf is 14" deep and acts as additional storage space
- Measures 72"W 78" D
- Maple top with square edge

ADJUSTABLE-HEIGHT SHOP STANDS

- Heavy-duty, easy-to-clear surface with 2,000 lb. capacity
- Bottom shelf and legs are height-adjustable at 3" increments
- Top shelf has 2 knockouts that accept duplex or plug-in outlets
- Adjustable-height 16-gauge steel shelves and 12-gauge steel legs
- Features "tension" frame construction to prevent sway

MODEL	W" x D" x H"	CONSTRUCTION
254840	24 x 18 x 18-24	Steel
254842	24 x 18 x 30-36	Steel
254844	36 x 24 x 18-24	Steel
254846	36 x 24 x 30-36	Steel
254840SS	24 x 18 x 18-24	Stainless Steel
254844SS	36 x 24 x 18-24	Stainless Steel



254844SS

**INDUSTRIAL-GRADE
SHOP & SHIPPING DESKS**

- Pigeonhole riser holds supplies and supports computer monitors
- Fights fatigue with height adjustments from 38" to 42½" H at 1½" increments
- Electrical duplex knockout holes for optional duplex outlet or plug-in outlet
- 34-½" W x 30" D work surface with 15" lower shelf for storage

MODEL	Type	Color
254635GY	Sloped Surface	Gray
249458	Sloped Surface	Blue



**PEDESTAL
SHOP DESKS**

- Secure storage and organization for shipping areas and workshops
- Steel-channel reinforced work surfaces
- Pigeonhole riser and recessed lower shelf
- Drawers feature both a cylinder lock and padlockable hasp

319063

**ENCLOSED CABINET
RECEIVING DESKS**

- Keep out dust and debris
- Sloped writing surface with a pigeonhole organizer
- Includes adjustable center shelf
- Features both a cylinder lock and padlockable hasp
- 34½" W x 30" D



300912GY

MODEL	Type	Color
300912GY	Cabinet	Gray
249509	Cabinet w/Pegboard	Blue
237407	Cabinet & Drawers	Gray



254635CBL

MOBILE SHOP DESKS

- Easily moves anywhere you need it
- Sturdy 14-gauge steel, 34½" W x 30" D
- Pigeonhole riser holds supplies, can support computer monitors
- 3" swivel with 2 locking casters

MODEL	Type
254635CBL	Sloped Open
300912CBL	Sloped Cabinet

**SAVE SPACE WITH
WALL MOUNTED DESKS**



B237006

**WALL-MOUNTED
RECEIVING AND
SHIPPING DESKS**

- Ideal for compact receiving areas
- Locked flip-top compartment or drawer options
- Features a large solid writing surface with pigeonhole riser
- Knockouts accept duplex outlet or plug-in outlet for drawer style only

MODEL	W" x D"	Type
B237006	24 x 22	Flip-top
634177GY	34½ x 30	Drawer



249997

**WALL-MOUNTED
FOLDING WRITING DESK**

- Ideal super-compact receiving desk
- Folding desk mounts to walls at desired work height
- Convenient compartment for pens and small tools
- Magnetic closure keeps door in place
- Cylinder lock with 2 keys for security



Indoff

MATERIAL HANDLING

Half A Century Of Material Handling Expertise

Indoff has been a nationwide distributor of material handling products since 1971. Our experienced Sales Partners access thousands of manufacturers to find the right product to meet your needs.

- Indoff is a full-service partner providing everything from design to install.
- Our specialization ranges from hand trucks to heavy-duty industrial machinery.
- Indoff can assist you with products including lockers, pallet racks, lighting mezzanines, safety and loading equipment, ergonomic equipment, ship-ping materials, industrial tools, modular walls, conveyor systems, & more.
- We provide access to the right product at competitive pricing from over 1,000 manufacturers.
- Indoff utilizes nationwide logistics firms to ensure proper transport of every order.

Here at Indoff, we:

- Ask the right questions and listen carefully to your answers
- Consider your needs from concept through completion
- Customize solutions based on current practices and future goals
- Provide access to hundreds of years of knowledge and experience
- Promise to strive to exceed your expectations
- Offer flexible financing options to help you manage cash flow



"Indoff gave us the best layout, the right products, and a good price backed by professional service, project management, and installation. We made the right decision."

- Atlantic Telephone

"The Indoff team is always very pleasant to work with, providing quick & proactive service to hundreds of branches throughout the country."

- Wells Fargo Home Mortgage

"Indoff is the sole provider of our office furniture. They have the knowledge & willingness to work any hour of the day to get the job done to our satisfaction."

- Michael Baker Corp.

Indoff

A Global Industrial Company

indoff.com

11816 Lackland Rd
St. Louis, MO
63146

Quality Products at Competitive Prices



JANITORIAL &
FACILITY MAINTENANCE



STORAGE
& SHELVING



FURNITURE & DECOR



CARTS & TRUCKS



SAFETY & SECURITY



MATERIAL HANDLING



FOODSERVICE
& RETAIL



WORKBENCHES